



Power Transformer Testing

Course Number: EE-03-955

PDH: 3

Approved for: AK, AL, AR, FL, GA, IA, IL, IN, KS, KY, LA, MD, ME, MI, MN, MO, MS, MT, NC, ND, NE, NH, NJ, NM, NV, NY, OH, OK, OR, PA, SC, SD, TN, TX, UT, VA, VT, WI, WV, and WY

New Jersey Professional Competency Approval #24GP00025600
North Carolina Approved Sponsor #S-0695
Maryland Approved Provider of Continuing Professional Competency
Indiana Continuing Education Provider #CE21800088
Florida Provider #0009553 License #868
NYSED Sponsor #274

This document is the course text. You may review this material at your leisure before or after you purchase the course. In order to obtain credit for this course, complete the following steps:

1) Log in to My Account and purchase the course. If you don't have an account, go to New User to create an account.

2) After the course has been purchased, review the technical material and then complete the quiz at your convenience.

3) A Certificate of Completion is available once you pass the exam (70% or greater). If a passing grade is not obtained, you may take the quiz as many times as necessary until a passing grade is obtained (up to one year from the purchase date).

If you have any questions or technical difficulties, please call (508) 298-4787 or email us at admin@PDH-Pro.com.



Transformers may be tested using AC or DC voltage. AC voltage is preferable to DC voltage for transformer testing because AC voltage simulates the internal stress that the transformers face during operating conditions. The following tests are routinely conducted in the field on the transformer:

- Excitation current test
- Insulating fluid dielectric tests
- Insulation PF test
- Insulation Resistance test
- TTR test
- Polarity test
- AC or DC hi-pot test
- Induced potential test
- Frequency response analyzer
- Dissolved gas analysis tests
- DC winding resistance
- Transformer core ground test
- Polarization recovery voltage test

AC Hi-Pot Test

The AC hi-pot test is used to assess transformer windings condition. Hi-pot test is suggested for all voltages, particularly those above 34.5 kV. For transformer routine maintenance testing, the test voltage should not surpass 65% of factory test voltage. Nevertheless, the hi-pot test for routine maintenance is typically not applied to transformers because of the possibility of damage to the winding insulation. Hi-pot test is typically used for acceptance testing or after transformer repair testing. The AC HV test value should not surpass 75% of the factory test value. When AC hi-pot tests are used for routine maintenance, the power transformer can be examined at rated voltage for 3 min instead of testing at 65% of factory test voltage. The AC hi-pot test values for voltages up to 69 kV are presented in Table 1.

Table 1. AC dielectric test for acceptance and routine maintenance for liquid-filled power transformers

Transformer winding voltage (kV)	Factory test AC voltage (kV)	Acceptance field test AC voltage, 75% (kV)	Maintenance periodic test, 65% (kV)
1.20	10	7.50	6.50
2.40	15	11.20	9.75
4.80	19	14.25	12.35
8.70	26	19.50	16.90
15.00	34	25.50	22.10
18	40	30.00	26.00
25.00	50	37.50	32.50
34.50	70	52.50	45.50
46.00	95	71.25	61.75
69.00	140	105.00	91.00

TTR Test

During TTR test voltage is applied to one transformer winding. Also, voltage on another winding on the same core is detected. In the case of a low voltage hand-crank powered TTR, 8 V AC is applied to the tested, low-voltage transformer winding and a reference transformer in the TTR set. The HV transformer windings and the TTR reference transformer are connected through null detecting equipment. After polarity has been

made at 8 V, when the null reading is zero, the dial readings show the ratio of the tested transformer.

In the case of an electronic TTR test set, a voltage (usually 80 V AC) is applied to the tested transformer HV winding. The voltage detected on the low-voltage winding is measured and the voltage ratio between high and low windings is determined. Voltage ratio is proportionally equal to turns ratio.

The TTR test gives the following:

- It checks the turns ratio and polarity of single- and three-phase power transformers, one phase at a time.
- It verifies nameplate ratio, polarity, and vectors.
- It checks polarity and the ratio (but not voltage rating) of transformers without markings. Tests consider all transformer no-load tap positions. Tests consider all load taps on load, tap changer (LTC) transformers if connected for voltage ratio control. On LTC transformers connected for phase angle control, ratio and polarity are completed only in neutral positions. If checked on load taps, measurements may be taken for reference for future comparison, but will deviate from nameplate ratings. LTC taps may be checked by using low three-phase voltage and reading volts and the phase angle for each.
- Find issues in power transformer windings, such as open-circuit and short-circuits of turn-to-turn sensitivity. The standard deviation as described in IEEE C57.12.00-2006, suggests that results should be within 0.5% of nameplate markings, with rated voltage applied to one winding. The TTR with accuracy of 0.1% is accepted as sufficiently accurate.

The following steps are used for completing the TTR test:

- Transformer is isolated and tagged and leads disconnected

- Check transformer nameplate
- Check the polarities and vectors (phasors)
- Determine ratios for each no-load and load tap position

The test connections are presented in Figure 1 a through c. In the case of an electronic TTR, a unity ratio check is also done, but null and zero checks are not mandatory.

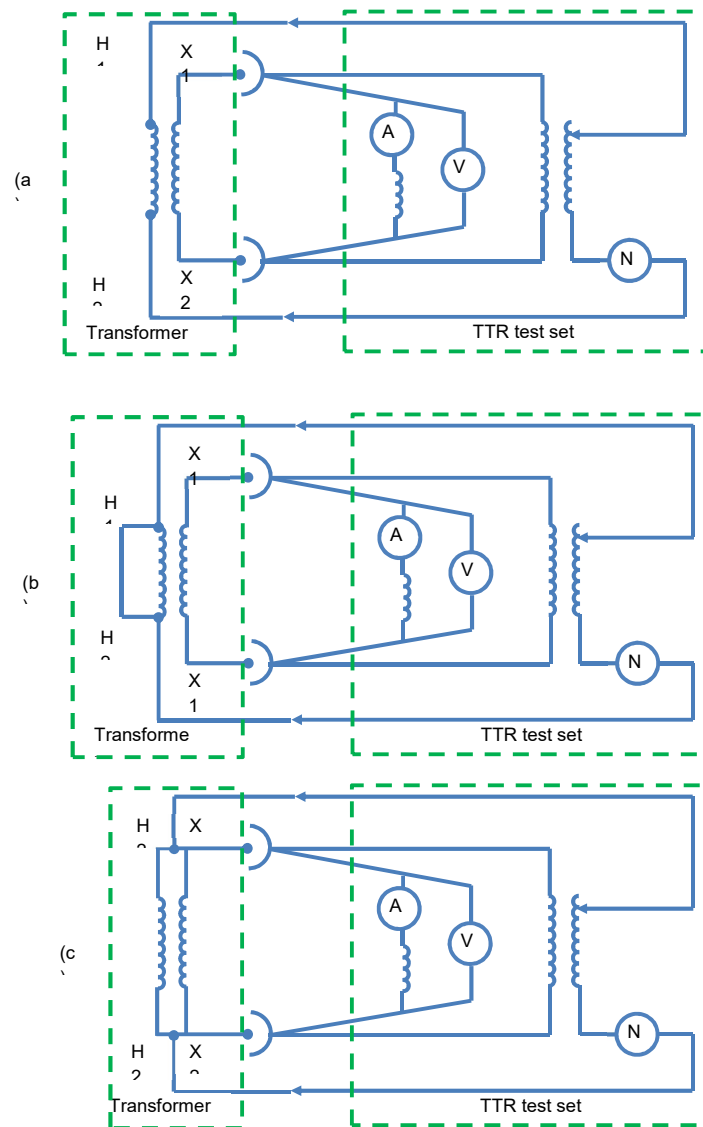

Figure 1. TTR test set connections; (b) test connection for null verification for TTR and (c) test connections for zero verification for TTR

Alternative Test for TTR

In case a TTR test set cannot be used, fast and rough test can be completed to verify the continuity and phase identification of transformer windings. The test consists of the following. The equipment required for this test is a 100 W lamp with socket and an extension cord for connection to a 120 V 60 Hz power supply, with which three test procedures are completed.

Test 1: Connect the 120 V, 60 Hz power through the lamp to the transformer primary, terminals as presented in Figure 2 (a). Leave the transformer secondary winding open. The lamp will burn dimly.

Test 2: Keep connections as presented in test 1, but now short the secondary winding. The lamp should burn with great brilliance. If the lamp still burns with somewhat less than full brilliance, check for issues in the transformer winding. Connections for this test are presented in Figure 2 (b).

Test 3: This test is similar to tests 1 and 2, but as applied to a three phase transformer for phase identification and phase continuity check. Complete tests 1 and 2 for each winding of a three-phase transformer individually with the remaining windings kept open. The test connection arrangement is shown in Figure 2 (c).

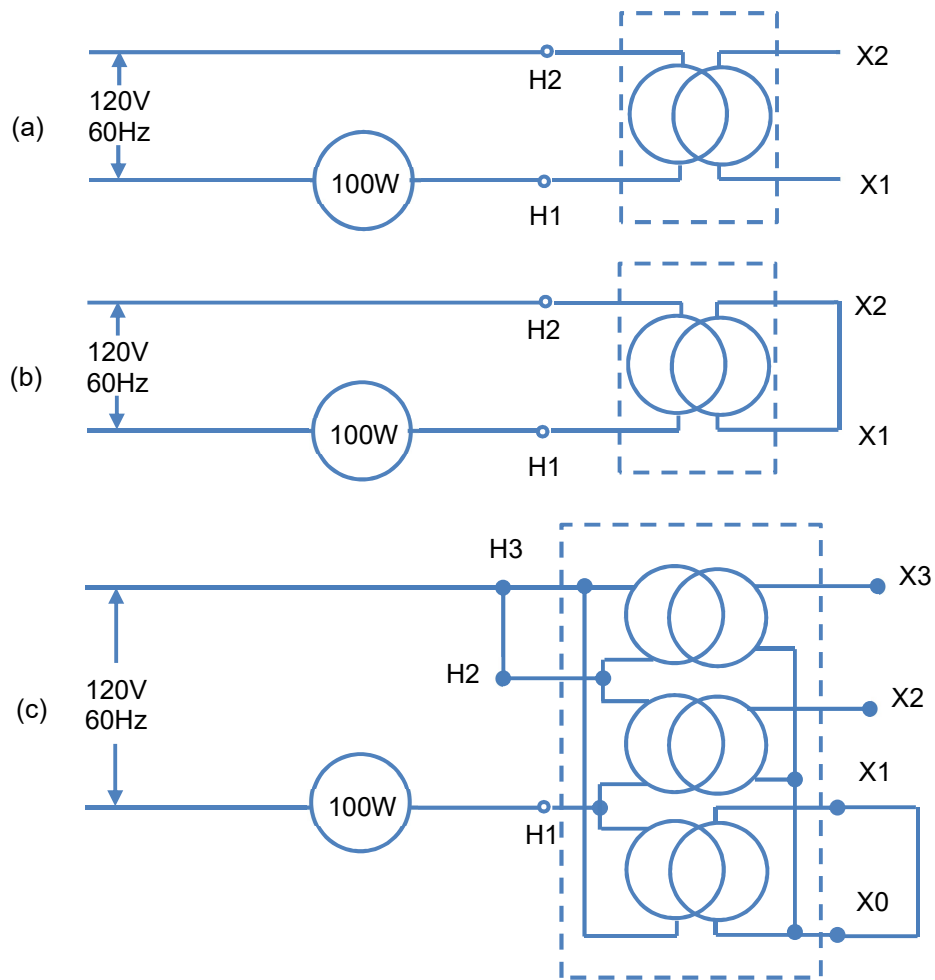

Figure 2. Transformer winding continuity verification

TTR Capacitor

The TTR test may be completed at higher voltages using a capacitor in combination with the PF test set. With the installation of the TTR capacitor the turns ratio of power transformers at potentials up to 10 kV can be measured. Installation of the capacitor in place of the common TTR test set, allows a greater test voltage, up to 10 kV that can be applied to the primary winding. Majority of TTR test sets are limited to less than 100 V which highly decrease the voltage on the secondary windings. The advantages of the HV TTR tests are that it can discover issues and anomalies in the electric and magnetic

circuit (core and coils) of the power transformer that cannot be discovered with the low-voltage TTR tests.

Polarity Test

The polarity test can be completed with the TTR on power, distribution, and potential transformers. Nevertheless, for current transformers the TTR test is not used. Instead a test typically known as the kick test is used. The kick test can also be used for power distribution, and potential transformers. Nevertheless, the TTR test is preferred. The connection arrangement for a kick test for a current transformer is presented in Figure 3. The DC battery voltage is typically about 7.5 V, and the multi-meter voltage range is set for 3 V full-scale. The battery negative terminal is connected to current transformer terminal H2 and the positive side is left hanging for the time being. The multi-meter positive terminal is connected to the transformer secondary terminal X1 and negative terminal to X2. To complete the test, touch the positive side battery jumper to transformer terminal H1 and notice the multi-meter scale indication, if the multi-meter scale kick is up scale, the transformer is connected in subtractive polarity. If the kick is down scale, it is connected in additive polarity.

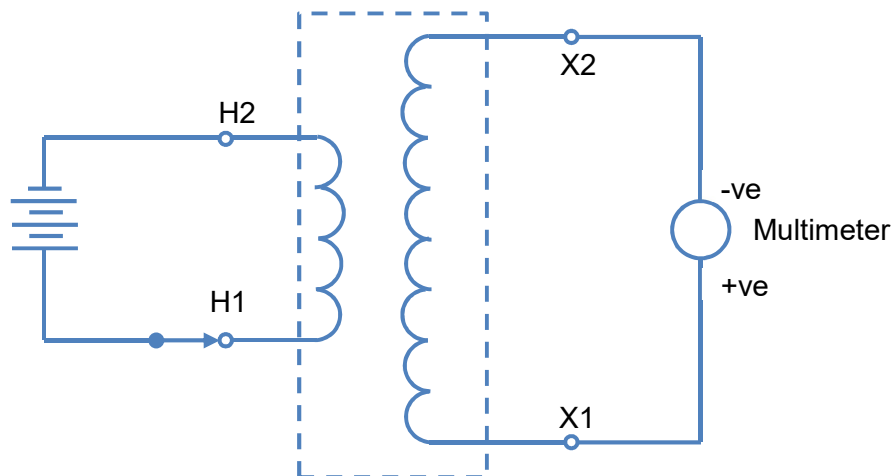

Figure 3. Polarity verification using the kick technique

Induced Potential Test

The induced potential check is a proof test and completed at higher voltage levels than normal operating voltages. Under this test, turn-to-turn insulation and line-to-line insulation are stressed at 65% of factory test voltage at frequency greater than 60 Hz, such as 200–300 Hz. The frequency of completing this test needs to be 5 years or more for big transformers. The induced potential verification for transformers which receive the full standard applied potential test is done by applying between the terminals of one winding a voltage of twice the normal voltage developed in the windings. This voltage is applied for 7200 cycles, and the duration should not surpass 60 s. Since the induced potential test overexcites the transformer, the frequency of the applied potential needs to be high enough to prevent the exciting current of the transformer, which should not exceed about 30% of its rated load current. Ordinarily this requirement requires the usage of a frequency of 120 Hz or more, when testing 60 Hz units. When frequencies greater than 120 Hz are applied, the test severity is abnormally increased and for this reason test duration needs to be decreased as presented in Table 2.

Table 2. Frequency versus test duration

Frequency (Hz)	Duration (s)
120 and less	60
180	40
240	30
300	20
400	18

The voltage needs to be started at one-quarter or less of the full value and increased up to full value in not more than 15 s. After being kept for the time presented in Table 2, it needs to be slowly decreased (in not more than 5 s) to one-quarter of the maximum value or less.

When power transformers have one winding earthed for operation on an earthed-neutral system, special attention needs to be taken to avert high electrostatic stresses between the other windings and earth.

In the case of power transformers having one end of the HV winding earthed during the induced potential test, earth on each winding may be made at a selected winding point or at the step-up transformer winding which is used to supply the voltage or which is merely connected for the purpose of furnishing the ground. Three-phase transformers may be checked with single-phase voltage. The specified test voltage is induced, from each line terminal to earth and to adjacent line terminals. The winding neutrals may or may not be held at earth potential during these tests. When the induced test on the winding results in a voltage between terminals of other windings in excess of the low-frequency test voltage, the other windings may be sectionalized and earthed. Additional induced tests need to be done to give the required test voltage between terminals of windings that were sectionalized.

FRA

The FRA test may be completed as an impulse response or as a SFRA test. The impulse method estimates the frequency response whereas sweep frequency response method measures the response over a range of frequencies of interest. Both the FRA and SFRA techniques are nondestructive tests used to understand if deformation of core and coils has taken place. Sweep frequency response is a major benefit in transformer condition assessment, allowing visualization of the inside of the transformer's tank without emptying the transformer tank. The standard definition of FRA is the ratio of a sinusoidal output from a test object exposed to a steady sinusoidal input. SFRA is a proven test for completing accurate and repeatable measurements. There is a direct relationship between the geometric arrangement of the winding and core, and the series and parallel impedance network of inductance, capacitance, and resistance. This network can be described by its frequency-dependent transfer function.

FRA assessment by the sweep frequency response technique uses network assessment tools to find the transfer function. Changes in the geometric arrangement affect the impedance network, and in turn affect the transfer function. This allows detection of a wide range of failure modes. Assessment of SFRA test results partly relies on comparison between phases and against old test results. Commonality

between similar transformers is also anticipated. Actually, SFRA checks are a series of many tests completed over a band of frequencies from 20 Hz to 2 MHz. The SFRA test results can be referred to as traces that can be presented on a graph. Traces present the ratio of the output voltage to the input voltage of the tested transformer circuit at each of the frequencies. It has been demonstrated that these traces are a signature that is related to the distributed resistance, inductance, and capacitance (RLC) of the transformer components. They are supposed to follow certain general shapes and favorable comparisons should exist among the transformer phases, with old test results, and among transformers of same design. The first, or benchmark, traces also give a valuable tool to identify winding movement in the future.

In comparison to the “impulse” procedure, SFRA is preferred for frequency domain verifications. It covers the full dynamic range and keeps the same energy level for each frequency, giving accurate, consistent results. A high signal-to-noise ratio across the entire 20 Hz to 2 MHz frequency range ensures correct measurements. Sweep frequency response analyzers discover mechanical failure or winding movements due to short circuits, mechanical shocks, or transportation. These checks are completed to ensure transformer performance, decrease maintenance cost, and increase overall transformer life. System faults, short circuits, aging, or improper handling can affect transformer’s mechanical structure. Since these issues are difficult to discover, they typically remain unnoticed and worsen over time, leading to complete performance loss and possibly failure. Until recently, the methods for dealing with these severe issues were limited. If such damage was suspected in a power transformer, the options were limited. These issues could be neglected and hope for the best, or empty transformer tank to complete costly and time-consuming visual inspection. Even that might not indicate the damage.

The sweep frequency response analyzer introduces a powerful tool to the quality control and maintenance equipment, allowing a look inside the transformer to discover even subtle changes in the core and winding mechanical structure—without emptying the transformer tank. This is the most efficient diagnostic tool for discovering mechanical

issues in power transformers. The instrument emits an excitation signal into the transformer and detects the returning signals. Comparing this response to baseline and other results (such as from similar units) allows detection of deviations. Common internal mechanical issues found in transformers with FRA are:

- Core displacement
- Partial winding collapse
- Faulty core grounds
- Shorted turns and open windings
- Broken or loosened clamping structures
- Winding deformation and displacement

Described test techniques are typically used on big HV power transformers because they are sensitive tests to discover winding distortion and deformation in power transformers. Considerable amount of deformation can happen in the windings as a result of high through fault currents which can remain undiscovered before an actual failure happens. The voltage stress changes in the winding insulation structure after the onset of initial winding deformation. Subsequently, the winding deformation will lead to partial discharges and gassing. Nevertheless, by the time partial discharge and subsequent gassing appear degradation of the transformer has already happened. Winding deformation is one of the first and basic precursors to show a degraded condition in the transformer windings. The FRA tests are completed at the factory and also in the field. The measurements are cross compared to check if changes have happened in the transformer. Special test equipment is needed to complete FRA or SFRA tests. Typically, the procedure requires the transformer to be de-energized and isolated. Each individual phase of every winding is examined. One set of tests is completed by injecting the signal at one end of the winding and measuring the other

end. Another test is completed by injecting the signal at one end of a primary winding and measuring the corresponding secondary winding.

DC Winding Resistance

This test checks the transformer winding DC resistance and is done with a low-resistance ohmmeter or a Kelvin bridge. Winding resistance will change due to loose connections, shorted turns or deteriorating contacts in tap changers. One of the issues related to measurement of the transformer DC resistance is the inductive circuit that must be energized. The inductance must be charged and stabilized in order to allow an accurate reading to be completed. Special low-resistance ohmmeters are available for the purpose of completing this test.

The test process for measuring DC winding resistance requires the transformer to be de-energized and disconnected. Both the primary and secondary terminals need to be isolated from external connections, and measurements completed on each phase of all windings. The measured resistance needs to be corrected to a common temperature such as 75°C or 85°C using the following formula:

$$R_C = R_M \times \left(\frac{CF + CT}{CF + WT} \right)$$

where

R_C is the corrected resistance

R_M is the measured resistance

CF is the correction factor for copper (234.5) or aluminum (225) windings

CT is the corrected temperature (75°C or 85°C)

WT is the winding temperature (°C) at time of test

Measurements need to be done on all tap changer positions and cross compared to older or factory test measurements. The test values after temperature correction need to be cross compared with the factory test values or older test results for transformer windings and leads condition assessment. The acceptance criteria for the field-measured values after temperature correction need to be within 2% of the factory values. A change bigger than the acceptance criteria suggests short-circuited turns, poor joints, or bad tap changer contacts. This test needs to be done during acceptance testing and when other maintenance electrical tests are done.

Transformer Core Ground Test

An IR measurement is made to discover the presence of unintentional core grounds. Generally, power transformer laminated cores are insulated from ground, and intentionally earthed at a single point. Typically this earthing point can be accessed at the top of the transformer, either externally at a small bushing or internally behind a manhole cover.

Unintentional core grounds can develop due to improper shipping, though faults, or deterioration of core insulation. Any of these issues can cause increased localized heating through circulating currents in the core and surrounding structure, causing generation of specific gases in the insulating oil. The routine for the test requires the transformer to be de-energized and isolated. The intentional core ground connection is lifted and the DC IR test is completed between the core connection and the earthed transformer enclosure. Acceptable readings are 100 M Ω or higher.

Polarization Recovery Voltage Test

The transformer insulation systems are composites of two insulating materials: cellulose fibre (paper) and insulating oil. This design shows space-charge polarization effects which are highly affected by the moisture content and aging products. These cause time constant reduction. The time constant caused by space-charge polarization surpasses 10ms and, in the case of new dry insulation, even 1000s. Figure 4 (a) presents the circuit of a recovery voltage meter.

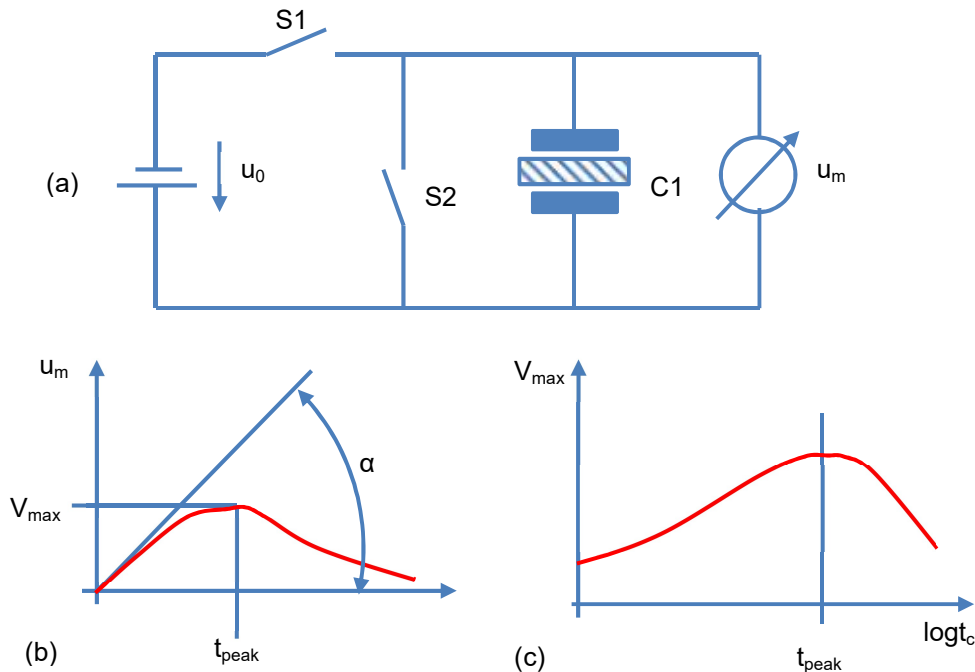

Figure 4. (a) The principle circuit of time t_c recovery voltage measurement, (b) Recovery Voltage Meter measurement cycle and the quantities recorded during one cycle, and (c) recovery voltage V as a function of time t_c

Switch S_1 is closed for a time t_c and DC voltage source U , applies a certain charge to the capacitor (test object). Switch S_1 then opens and switch S_2 closes for a time t_d (typically $t_d = t_c/2$). Part of the capacitor charge is dissipated, then switch S_2 opens and the residual capacitor charge generates a voltage at the capacitor electrodes (Figure 4 (b)). Two common parameters of this so-called recovery voltage are its maximum value (V_{max}) and initial slope ($\tan \alpha$). If the time t_c is increased, along with time t_d from a small initial value, a different value of V_{max} and initial slope $\tan \alpha$ will be obtained for each time t_c . Figure 4 (c) presents the variation of V_{max} with t_c . It is easily proved that the V_{max}/t_c curve peaks at the time constant value, i.e., $t_{critical} = T$. This result suggests that the V_{max}/t_c curve also represents a polarization spectrum with maximum value at the insulation time constants.

The Measuring Instrument

Instruments are developed for automatic completion of the series of required measurements for determination of the spectra polarization. These systems are portable microprocessor-controlled automatic units that are also suitable for field use. Measurement results are presented in digital form. Operation and adjustment of the instrument is done through a menu-driven program, with a possibility for completely automatic measurement sequences or single manual measurements where needed. Instruments have LCD screen display and an alphanumerical printer for test data results.

Typical features include an RS232C interface and screened two-core HV cable for connection to the test object. Assessment software analyses the data and generates definitive moisture content as a percentage (%) of paper mass and a qualitative interpretation of polarization spectrum. The typical settings in the automatic measurement program ensure efficient acquisition of the significant part of the polarization spectrum for power transformer oil/paper insulation. Typically, in automatic measurement mode the instrument displays:

- Recovery voltage peaks
- Initial slopes with corresponding charge time t_c
- All measured parameters (U_{max} , $\tan\alpha$, t_c), the typical values (t_c/t_d) will be saved, displayed, and/or printed out

Test Setup for Power Transformers Recovery Voltage Measurement

As presented in Figure 5, the transformer terminals need to be disconnected from the system. The ends of the low-voltage windings need to be joined and connected to the HV core of the instrument test lead. The ends of all other windings need to be joined together and connected to the tank earth and the low-voltage core of the test lead. The

instrument has the capability of charging voltage at 2000 V DC, $t_c/t_d=2$, and t_c time range of 10ms to 10,000 s.

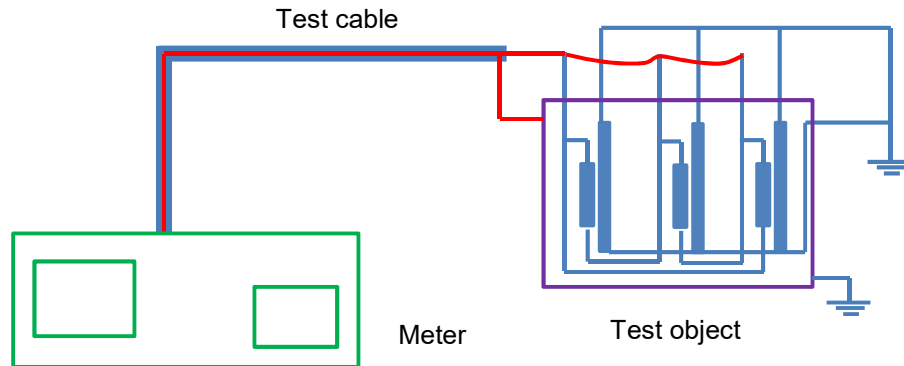

Figure 5. Power transformer RVM test setup

Assessment of Measured Polarization Spectra

The electrical features and reliability of the oil/paper insulation used on majority of power transformers greatly depend on the state (aging and moisture content) of the oil and, even more so, on that of the paper. Oil condition is rather easily checked by conventional oil sample analysis methods such as Karl-Fischer moisture measurement, PF, etc. However, these provide limited details on the condition of the paper insulation. Condition of oil-impregnated paper can be directly ascertained from the polarization spectrum without any need to take and assess an oil sample.

Figure 6 presents typical spectra measured at constant temperature on oil impregnated paper insulation laboratory models. The curves in Figure 6(a) present spectra recorded at varying moisture content on the insulation model. Figure 6(b) presents similar curves obtained under artificial aging of varying duration.

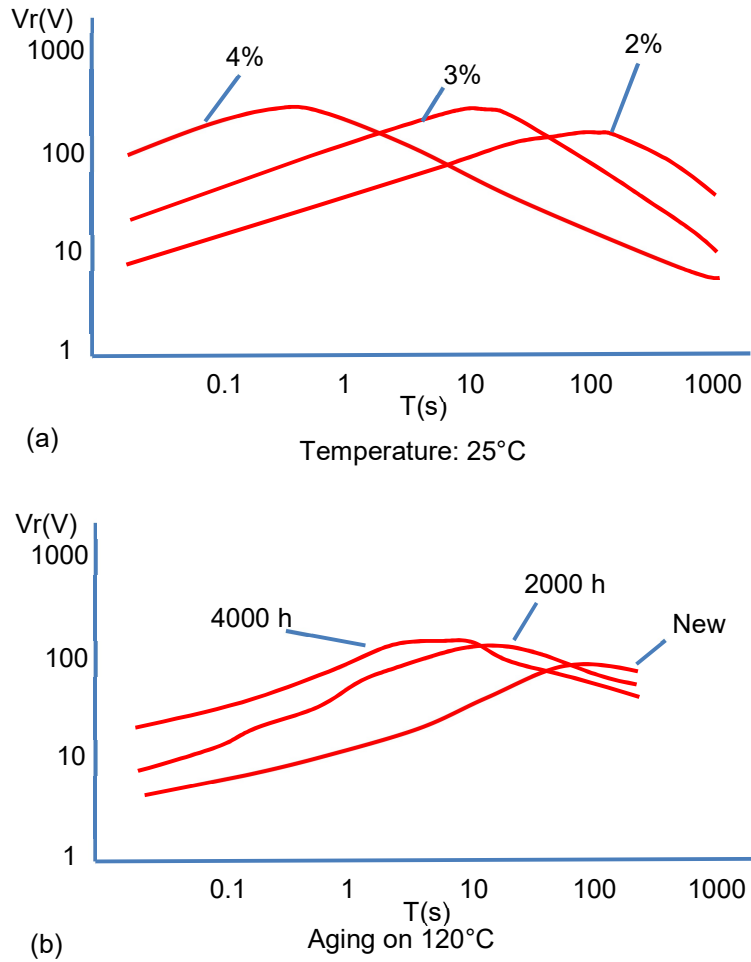

Figure 6. Polarization spectral curves relative to (a) moisture at 25°C and (b) aging at 120°C

These curves indicate that the behavior of the spectrum (particularly displacement of the curve peak toward small time constants) closely reflects condition changes, i.e., dielectric degradation, i.e., oil/paper insulation.

Power Transformer Online Condition Monitoring

Power transformers are vital and expensive assets in the electric power system beginning with the grid, transmission, and down to the plant. They are one of the crucial elements for providing reliable energy flow. As an asset class, power transformers make one of the biggest investments in a utility's system or in an industrial complex. For this

reason power transformer condition assessment and management is one of the greatest priorities. Each entity is unique and investment levels in asset condition and assessment management changes according to risk level and investment return models. Even though the models are different for each entity, the common element in them is that transformers are stratified according to the criticality of individual transformers. This approach means that the most critical transformers get the biggest condition assessment investment and management tools while less-critical or noncritical transformers get lower levels of asset allocations. A simplified model below presents one approach to transformer condition assessment:

Critical: If failed, these power transformers would have a considerable, negative impact on grid stability, utility revenue, and service reliability of the critical facility. Generator step-up transformers (GSU) and transmission transformers that are part of critical power corridors fall in this group.

Important: If failed, these transformers would have a considerable, negative effect on revenue and utility system service reliability, or the plant production. Transmission substation transformers and major distribution substation transformers are commonly in this group.

Recoverable: If failed, these transformers would have low impact on revenue and plant reliability. Typically, these are smaller distribution substation transformers.

Transformer reliability is more critical today than was in the past. Transformers do not last as long they used to in the past. In the United States, the average life of a transformer is 40 years, and many power transformers installed in the 1960s and 1970s are now reaching the end of their design life. Bigger loads placed on power transformers, in a market that demands more energy, have also taken their toll on transformer longevity. Due to consolidation and deregulation of the electric industry, maintenance and condition monitoring budgets have been decreased. Hence, the requirement to more closely manage transformer assets becomes even more important these days. Utility and plant managers by selecting adequate transformer condition

monitoring tools can prevent unplanned failures, lower maintenance costs, and defer capital expenditures in replacement cost. Condition management is all about selecting proper transformer monitoring tools.

Transformer Online Monitoring

Several online monitoring systems can be used for continuously assessing the condition of big and critical power transformers. The online monitoring systems readily available on the market include DGA, PF monitoring of bushing, leakage current monitoring of lightening arrestors, and FRA of transformer windings. The bushing and lightening arrestors are externally installed auxiliaries on a power transformer. Hence, they are more susceptible to different environmental conditions. Damage in the transformer bushing or lightening arrestor is a failure of the power transformer. As previously mentioned, the online testing gives another management tool for condition monitoring and assessment of the most important transformers.

DGA: The DGA is one of the many tests that are applied for monitoring the health of oil-filled power transformers. The off-line DGA tests have been commonly completed using laboratory DGA analysis performed at periodic intervals, such as on quarterly, semiannually, or yearly basis. DGA of transformer oil is the single best indicator of transformer overall condition and is completed without taking it out of service. Now, this is a common practice that got started in the 1960s. While laboratory or portable DGA is the common practice, application of online DGA tools has gained in popularity. The reason for this is the requirement for utilities to maintain or improve their reliability in the presence of decreased capital expenditures and an aging infrastructure. Something more than periodic laboratory or portable DGA is required to be successful in the current environment and the two approaches (online DGA and laboratory DGA) now coexist at many utilities. Online DGA assists utilities to avoid unplanned interruptions, adopt cheaper condition-based maintenance, and defer capital expenditures by extending the transformer's useful service life. First generation products, as well as certain current online DGA products, provided total combustible gas (TCG) or single gas (hydrogen) monitoring. This equipment provides indication of developing issues in the

transformer but offer no legitimate diagnostic features. Online DGA equipment have evolved from this early approach to include multi-gas monitors that discover and analyze some or all of the eight fault gases specified in the IEEE standards. They also provide diagnostic features. Newer online DGA equipment have the unique feature to permanently trend several transformer gases and relate them with other key parameters such as transformer load, oil, and ambient temperatures as well as customer-specified sensor inputs. This feature allows utilities to relate gassing to external incidents, a key to meeting utility reliability and financial goals in the current environment. Certain online DGA equipment may provide improved accuracy and repeatability than laboratory DGA. This can enhance the transformer asset manager's decision timeliness and confidence when incipient faults are discovered. With the arrival of online DGA monitoring, there has also been new discoveries about the nature of transformer faults. Online DGA monitoring has introduced numerous case studies that show the development of critical faults, which could cause catastrophic transformer collapses if left undetected, in timeframes from a few days to several weeks. There is a low chance of detecting these quickly developing fault conditions with a laboratory or portable-based transformer DGA testing equipment. The ability to automatically supplement traditional DGA diagnostic tests with online DGA tests is also available in the market. This improvement provides users of online DGA monitors unprecedented insight into the nature and identification of developing faults. Equipment is usually ratio-based and the online data set enables trending of fault gas ratios over time rather than the traditional static snapshots. Diagnostic results can be quickly determined and with greater certainty. Neural network diagnostic methods using DGA data are also new to the market and promise better diagnoses but have not yet been included in industry standards.

One of the online tools that are available for transformer condition monitoring is online DGA. This tool is a self-contained completely automated closed-loop gas chromatograph made to be installed on or near the transformer. This device generates individual measurements of each of the eight important fault gases (hydrogen, nitrogen, carbon monoxide, carbon dioxide, methane, ethane, ethylene, and acetylene) found in transformer oil.

These monitoring devices allow condition assessment information to be incorporated into the configuration of alarms and recommended loading to avoid the failure risk while preserving operation. Even though no system can guarantee failure avoidance these devices can utilize the results of field-based condition assessments and advanced monitoring and diagnostic technology to give a comprehensive tool to support any asset management strategy. These instruments provide contextual information on maintenance actions to address abnormal service, on potentially related or causal relationships between transformer elements and the alarmed condition.

Selecting online DGA equipment - The last several years have seen a new array of DGA equipment enter the market and this poses challenges for utility and plant managers to understand and select an approach that best meets their requirements. Transformer asset managers need to make important decisions, including whether or not to take a transformer offline in order to avoid a catastrophic damage. Such decisions can considerably affect service reliability, revenue, and production. The aging infrastructure and increasing electricity requirements placed on existing transformer assets is exacerbating the issue. Higher loading on older transformers is creating faults that can cause catastrophic failure to develop faster and more often. The transformer reliability bathtub curve suggests that new transformers are not immune to failure either. This puts extra pressure on transformer asset managers to make important reliability and revenue decisions more quickly and more often than in the past. Each transformer asset manager must select the amount and type of transformer condition data they need for each level in their condition management model to make these important decisions. In response to this requirement the vendor community has developed equipment that better support the asset manager's decision integrity by providing timely, accurate and certain transformer DGA data and diagnostic tools.

The increasing variety of different online DGA equipment, while helpful to the industry overall, presents transformer asset managers with the challenge of matching the right equipment to their needs. A framework for decision making is needed. The first step is to determine a transformer condition management structure. For needs of this

discussion, the structure presented above will serve the purpose. The structure discussed above has three levels of transformer assets: critical, important, and recoverable. Table 3 presents a list of attributes for different online DGA product categories that are relevant to online DGA tool selection and how it could be applied to the three levels of transformer assets. This attribute list has to be considered when applying online DGA to the different condition management model levels.

Table 3. Online DGA category attributes

Attribute	Number of gases			
	8	3	2	1
Gases	All IEEE fault gases	CH ₄ , C ₂ H ₄ and C ₂ H ₂	C ₂ H ₂ and H ₂	H ₂
Fault coverage	Best All fault detected with DGA	Better Partial discharge, arching and thermal faults	Minimal Arching, all other faults undetermined	Poor Undetermined faults
Price	Higher	Low	Lower	Lowest
Transformer assets	Critical GSU, major transmission transformers	Important Transmission and major distribution substation transformers	Recoverable Smaller distribution substation transformers	
H ₂ – Hydrogen, CH ₄ – methane, C ₂ H ₄ – ethane and C ₂ H ₂ - acetylene				

Online DGA equipment can be classified by attributes directly resulting from the number of measured gases. Majority of modern online DGA instruments provide the ability to measure other parameters such as moisture-in-oil. These parameters are not presented in the Table 3 since they are common for most.

Diagnostics - Fault coverage and diagnostics capacities are the important attributes that transformer asset managers need to consider when selecting online DGA tools for the different levels in their stratification models. Price is also important consideration, but the relative value of the solution, as defined by the fault coverage and diagnostic capabilities, is the more important aspect. In other words, some solutions may be more expensive, but the provided value (through superior transformer condition knowledge) in

terms of enhanced utility service reliability and revenue far outweighs the bigger price. The selection of online DGA tools for each level of transformer assets reflects the approach of making the biggest investment in online DGA tools for the most critical transformers and less investment in tools for lower levels in the stratification model. This approach uses the online DGA equipment with the most fault coverage and diagnostics for the critical and important transformers in the fleet. Utilities will find more appropriate returns on investment for their critical and important power transformers with online DGA tools that provide good fault coverage and diagnostics capacity rather than with the lowest cost, poor fault coverage tools that lack diagnostic support. The current environment of bigger loading on aging transformers, deferred capital expenditures as well as increased service reliability demands indicates that transformer asset managers need to take advantage of the improved online DGA equipment (i.e., better fault coverage and diagnostics) to get the best protection for its biggest asset class—at all levels. Adequate online DGA monitoring and diagnostic equipment will assist utilities in avoiding unplanned failures, lower maintenance costs, and extend transformer useful service life.

Bushings and Lightning Arrestors Online Monitoring

The deterioration of oil and paper insulation in HV equipment is a matter of permanent concern. Common aging of HV equipment is a slow process that takes place over 30–40 years due to thermal, electrical, and environmental impacts. With regard to transformer bushings, the most typical bushing failure happens due to a failure in the internal bushing capacitive layers. These failures happen slowly over time with one layer slowly failing and burning through the kraft paper. On the other hand, premature damage is a relatively sudden process that is not discovered by periodic off-line tests. The application of the Scherring bridge method using the voltage is very responsive to type of condition, and can discover these millivolt level changes. The millivolt level changes are far too small for an offline test to discover and react to it in the early failure stages. This asked for permanent online insulation condition monitoring to manage the risk of premature bushing failures and to start maintenance procedures based on the bushing insulation condition. System for online PF ($\tan\delta$) transformer bushings and

lightening arrestors testing was developed. This testing is done while the transformer remains energized. This technique is based on the conventional Schering bridge used in laboratories. Data is obtained under software control from transducers connected to the bushing PF/capacitive tap associated with a transformer and then the data is cross compared to data from another electrical phase to generate a PF value. Damaged or deteriorated dielectric is related with increased dielectric losses (I^2R) and with other sources of heating that may eventually fuel a mechanism of thermal runaway. The final insulation breakdown is a quick avalanche of failing dielectric layers. PF is a measure of dielectric losses, partial discharges, and treeing. Increased levels of partial discharge are reflected in the PF and are typically only present just after lightning or switching impulses and just before and during insulation damage.

Online monitoring system, for monitoring PF in HV capacitive bushings are also available with an optional leakage current monitor for HV lightning arresters. The system includes a minimum set of three sensors permanently connected to a series of capacitive bushing taps, or lightning arresters. Systems are capable of monitoring up to 32 direct-connected sensors, and up to 256 wireless sensors. The system collects, analyzes, and trends data pertaining to AC insulation PF of bushings and/or HV current transformers, and leakage current of lightning arresters. System can also interface to signals from other devices, or IED's providing a single access point for transformer mounted sensors. Data can be accessed on-site, or remotely. The concept of measuring PF is based on the derivation of the phase shift between two voltage signals. This technique is similar to the standard bridge techniques, but software is used for angle difference determination. The measurement of PF of insulation is accepted as part of well-established laboratory testing procedures to understand the insulation quality at the factory before commissioning new and refurbished HV equipment. PF as a parameter is a relatively slow-changing value and is an integral characteristic that depends on design, materials, and production technology.

The system determines the PF of a unit as a relative value compared with a reference voltage from another unit in service, thereby eliminating the requirement for a standard

capacitor. The reference device does not have to be related with the same phase since equipment will automatically make the adequate phase angle adjustments. Relative measurements and evaluation can decrease the effect of influences such as ambient temperature, operating voltages, loading conditions, different aging characteristics, different configurations, operating conditions, etc. The system uses a principle of cross-referencing units in a closed loop to confirm all measurements and increase the confidence of isolating a failed element. Since, the system uses relative measurements the minimum number of units to be monitored is three. All measurements are tested for integrity against three parameters: RMS and mean of the signal, and the calculated PF value. Only measurements that successfully pass the integrity tests are kept in the database. The default monitoring interval is once every 5 min. This setting can be changed from once a minute, to once per day. The sensors are set into the graphical user interface by the user during installation process. Each monitored element is entered into the database with an acquisition channel number, and descriptive text. The status and condition of each monitored element is shown on the monitor screen.

FRA: National Electric Energy Testing, Research and Application Centre (NEETRAC) developed a technique to complete this test while the transformer is in service. Online FRA data can give an up-to-date condition assessment of big, important transformers. Online FRA gives yet another tool to assess the physical structure of the coils and their dielectric surroundings while the transformer remains energized. NEETRAC's online FRA technique uses typical system-switching operations, such as capacitor bank and reactor operations, along with lightning from local thunderstorms for the FRA test-signal source. NEETRAC's patented method can complete FRA signatures on transformer windings using a variety of input waveforms with different time and amplitude shapes.