



## Shunt Capacitor Bank Design and Protection Basics

**Course Number:** EE-04-922

**PDH:** 4

**Approved for:** AK, AL, AR, FL, GA, IA, IL, IN, KS, KY, LA, MD, ME, MI, MN, MO, MS, MT, NC, ND, NE, NH, NJ, NM, NV, NY, OH, OK, OR, PA, SC, SD, TN, TX, UT, VA, VT, WI, WV, and WY

New Jersey Professional Competency Approval #24GP00025600  
North Carolina Approved Sponsor #S-0695  
Maryland Approved Provider of Continuing Professional Competency  
Indiana Continuing Education Provider #CE21800088  
Florida Provider #0009553 License #868  
NYSED Sponsor #274

This document is the course text. You may review this material at your leisure before or after you purchase the course. In order to obtain credit for this course, complete the following steps:

- 1) Log in to My Account and purchase the course. If you don't have an account, go to New User to create an account.
- 2) After the course has been purchased, review the technical material and then complete the quiz at your convenience.
- 3) A Certificate of Completion is available once you pass the exam (70% or greater). If a passing grade is not obtained, you may take the quiz as many times as necessary until a passing grade is obtained (up to one year from the purchase date).

If you have any questions or technical difficulties, please call (508) 298-4787 or email us at [admin@PDH-Pro.com](mailto:admin@PDH-Pro.com).



## **SHUNT CAPACITOR BANK DESIGN AND PROTECTION BASICS**

### **Introduction**

Shunt capacitor units are typically used to deliver capacitive reactive compensation or power factor correction. The use of shunt capacitor units has gained popularity because they are quite affordable, simple to install and commission and can be placed anywhere in the electrical distribution system. Its usage has additional advantages on the electrical distribution system such as: enhancement of the voltage at the load side, increased voltage regulation, decrease of power losses and decrease or postponement of investments in electrical transmission network. The primary weakness of the shunt capacitor units is that its reactive power generation is relative to the square of the voltage and accordingly when the voltage is low and the electrical system needs them most, they are delivering the least amount of the reactive power.

### **The capacitor unit and bank arrangements**

#### **The capacitor unit**

The capacitor unit is the essential element of a shunt capacitor bank. The capacitor unit consists of individual capacitor segments, connected in parallel/series arrangements, within a steel case. The internal discharge element is a resistor that decreases the unit residual voltage to 50V or less in 5 min. Capacitor units come in a range of voltage ratings (240 V to 24940V) and ratings (2.5 kvar to about 1000 kvar).



Figure 1. Typical capacitor bank arrangement

### **Shunt capacitor unit features**

Protection of shunt capacitor units calls for knowledge of the advantages and restrictions of the capacitor unit and related electrical devices that include: individual capacitor elements, bank switching equipment, fuses, voltage and current sensing elements. Capacitors are meant to be run at or below their rated voltage and frequency since they are highly sensitive to these parameters; the reactive power produced by a capacitor element is relative to both of them ( $kVar \approx 2\pi fV^2$ ). Standard sizes of the capacitors elements made for shunt interconnection to AC electrical systems are given in IEEE Std 18-1992 and Std 1036-1992. These standards also give application guidelines. These standards specify that:

- Shunt capacitor units need to be designed for continuous service up to 110% of rated terminal RMS voltage and a crest voltage that does not exceed  $1.2 \times \sqrt{2}$  of rated RMS voltage, taking into account harmonics but omitting transients. The

shunt capacitor units should also be able to withstand 135% of nominal current.

- Shunt capacitors units should not provide less than 100% or more than 115% of rated reactive power at rated sinusoidal voltage and frequency.
- Shunt capacitor units are not supposed to be suited for continuous service at up to 135% of rated reactive power made by the mixed impacts of:
  - Voltage in extra of the nameplate rating at fundamental frequency, but not over 110% of rated RMS voltage.
  - Harmonic voltages laid over on the fundamental frequency.
  - Reactive power fabrication margin of up to 115% of rated reactive power.

### Shunt capacitor bank arrangements

The function of fuses for protection of the shunt capacitor elements and its location (inside the capacitor unit on each element or outside the unit) is a significant topic in the design of shunt capacitor banks. They also impact the failure modality of the capacitor element and impact the setting of the capacitor bank protection. Depending on the usage any of the described arrangements are appropriate for shunt capacitor elements:

- External fuse - A separate fuse, externally installed between the capacitor element and the capacitor bank fuse bus bar, generally protects each shunt capacitor element. The shunt capacitor element can be made for a comparatively high voltage since the external fuse can clear a high-voltage fault. Application of capacitor elements with the greatest possible voltage rating will lead to shunt capacitive unit with the lowest number of series groups.

A fault of a capacitor element welds the foils together and causes short circuit currents to flow between capacitor elements arranged in parallel in the same group. The remaining capacitor elements in the bank stay in operation with an increased voltage

across them than before the fault and an increment in capacitor element current. If a second element breaks down the procedure duplicates itself causing an even greater voltage for the remaining elements. Sequential faults within the same bank will make the fuse to trip, unplugging the capacitor element and suggesting the failed one.

Externally fused shunt capacitor units assembled using one or more series groups of parallel-connected capacitor elements per phase as shown in Figure 2. The unbalance signalling level reduces as the number of series groups of capacitors is raised or as the number of capacitor elements in parallel per series group is grown. Nevertheless, the reactive power rating of the separate capacitor element may require being littler since a minimum number of parallel elements are needed to allow the shunt capacitor bank to stay in operation with one fuse or unit out.

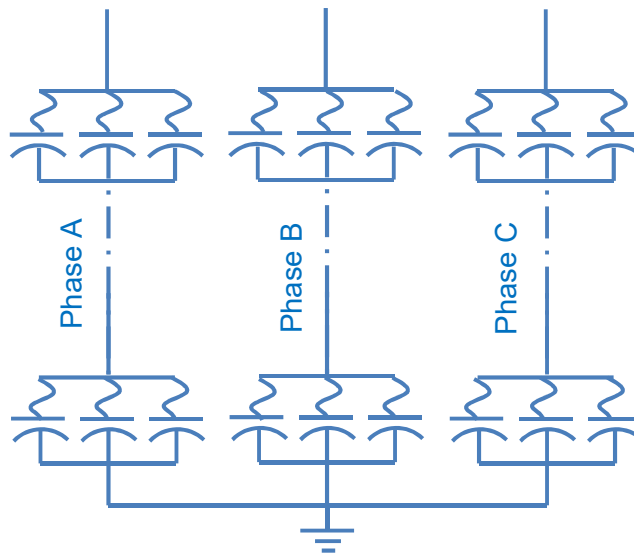

Figure 2. Shunt capacitor bank with external fuses

### **Shunt capacitor bank with internal fuses**

Each capacitor element has fuse inside the capacitor element. The fuse is a basic part of wire sufficient to limit the current and capsulized in a wrapper that can resist the heat generated by the arc. Upon a capacitor element fault, the fuse takes out the struck element only. The remaining elements, linked in parallel in the same arrangement, stay

in operation but with a somewhat increased voltage across them.

Common capacitor bank that uses capacitor elements with internal fuse is shown in Figure 3. Generally, shunt capacitor using capacitor elements with internal fuses are assembled with less capacitor elements in parallel and more series groups of elements than are utilized in banks employing elements with internal fuses. The capacitor elements are typically big because the whole unit is not anticipated to break down.

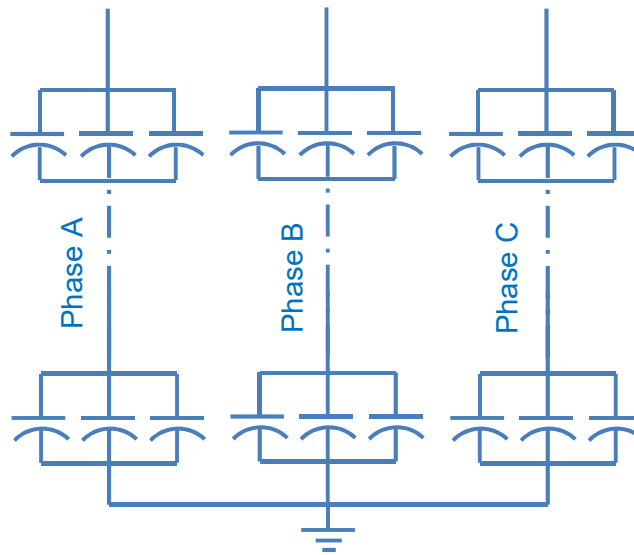

Figure 3. Shunt capacitor bank with internal fuses

**Fuseless shunt capacitor units** - The capacitor elements for capacitor banks without fuses are same to those with external fuses. To make a bank, capacitor elements are arranged in series chains between phase and neutral, as displayed in Figure 4.

The protection is founded on the capacitor elements (inside the unit) breaking down in a shorted mode, causing short circuit in the group. Once the capacitor element breaks down it welds and the capacitor unit stays in operation. The voltage across the broken capacitor element is then split among left over capacitor element groups that are connected in the series. For instance, in the case there are 6 capacitor units connected in series and each unit consists of 8 element groups in series there is a total of 48 element groups connected in series. If one capacitor element breaks down, the element

is bridged and the voltage on the left over elements is  $48/47$  or around a 2% increment in the voltage. The capacitor bank remains in service; nevertheless, consecutive break downs of elements will cause removal of the bank. The design without fuses is not typically used for system voltages lower than about 34.5 kV. The cause is that there shall be more than 10 elements connected in series so that the capacitor bank does not have to be taken away from operation for the breaking down of one element since the voltage across the left over elements would grow by a factor of about  $E(E - 1)$ , where  $E$  is the number of elements in the chain.

The discharge energy is insignificant since no capacitor units are linked directly in parallel. Additional benefit of units without fuses is that the unbalance protection does not have to be stayed to achieve coordination with the fuses.

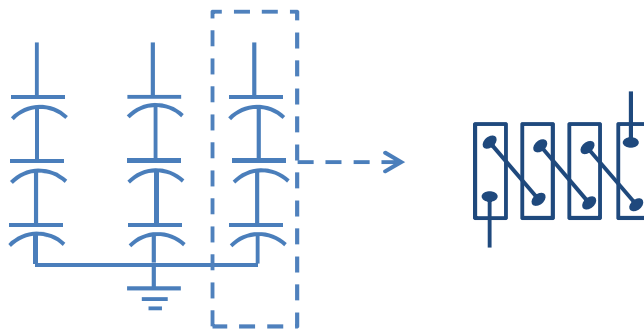

Figure 4. Shunt capacitor bank and series chain without fuses

**Unfused Shunt Capacitor Units** - Opposite to the fuseless arrangement, where the units are linked in series, the unfused shunt capacitor bank applies a series/parallel arrangement of the capacitor units. The unfused arrangement would typically be utilized on units below 34.5 kV, where series chain of capacitor units are not practical or on higher voltage units with small parallel energy. This arrangement does not need as many capacitor units connected in parallel as bank with external fuses.

### Design of the capacitor bank

The protection of shunt capacitor units needs apprehension the fundamentals of capacitor bank construction and capacitor unit connections. Shunt capacitors units are

systems of series/paralleled linked units. Capacitor units organized in paralleled form a group and series linked groups form a single-phase capacitor bank.

As a universal rule, the minimum number of units linked in parallel is such that isolation of one capacitor unit in a group should not induce a voltage unbalance enough to place more than 110% of rated voltage on the staying capacitors of the group. As the minimum number of series linked groups is that in which the total bypass of the group does not subject the ones staying in operation to a lasting overvoltage of more than 110%.

The maximum number of capacitor units that may be put in parallel per group is ruled by a unlike conditions. When a capacitor bank unit breaks down, remaining capacitors in the same parallel group hold some amount of charge. Charge will disappear in a form of a high frequency transient current that goes through the broken down capacitor unit and its fuse. The fuse holder and the broken down capacitor unit should resist this discharge transient.

The discharge transient from a big quantity of paralleled capacitors can be serious enough to tear the broken down capacitor unit or the expulsion fuse holder that may end in damage to next units or induce a serious bus break down within the bank. To derogate the probability of breaking down of the expulsion fuse holder, or damage of the capacitor case, the standards enforce a limit to the overall maximum energy stacked away in a paralleled linked group to 4659 kVar. In order not to breach this boundary, more capacitor groups of a lower voltage rating linked in series with less units connected in parallel per group may be adequate answer. Nevertheless, this may decrease the sensitivity of the unbalance detection system. Dividing the bank into two parts as a double Y may be the favoured answer and may provide better unbalance detection system. Another option is the utilization of current limiting fuses.

The optimum arrangement for a shunt capacitor bank depends on the best usage of the available voltage ratings of capacitor units, fuses, and protective relaying. Nearly all substation units are linked wye. Distribution capacitor units, nevertheless, may be linked



wye or delta. Some units utilize an H arrangement on every phase with a current transformer in the associating branch to discover the unbalance.

### Units connected in grounded Wye

Grounded wye capacitor units consist of series and parallel-linked capacitor units per phase and allow for a low impedance path to ground. Common bank arrangements are shown in Figure 5. Benefits of the grounded capacitor units are:

- Low-impedance path to ground allows for underlying self-protection for lightning surge currents and provide protection from surge voltages. Shunt capacitor units can be functioned without surge arresters using the capability of the capacitors to absorb the surge.
- Provide a low impedance path for high frequency currents and so they can be utilized as filters in arrangements with high harmonic content. Nevertheless, care is needed to prevent resonance between the shunt capacitor bank and the electrical system.
- Diluted transient recovery voltages for circuit breakers and additional switching devices

Some disadvantages for grounded wye shunt capacitor banks are:

- Larger interference on telecom circuits due to harmonics.
- Circulation of inrush currents and harmonics may induce disorder and/or over-operation on protective equipment.
- Phase connected series reactors are needed to decrease voltages coming out on the CT secondary due to the result of high frequency, high amplitude currents.

### Multiple units connected in series phase to ground – double Wye

Once a capacitor bank gets too big, building the parallel energy of a series group too big (above 4650 kvar) for the capacitor units or fuses, the bank may be divided into two wye parts. The features of the grounded double wye are alike to a grounded single wye bank. The two neutrals need to be linked with a common link to ground. The double Wye arrangement provides a safe and quicker unbalance protection with an uncomplicated, uncompensated relay since any system zero sequence component impacts both wyes evenly, but a broken down capacitor unit will come out as an unbalanced in the neutral. Time coordination may be needed to grant a fuse, in or on a broken down capacitor unit, to blow. If it is design without a fuse, the time delay may be adjusted short since no fuse coordination is needed. If the current through the string outperforms the uninterrupted current capability of the shunt capacitor unit, more chains need to be lent in parallel.

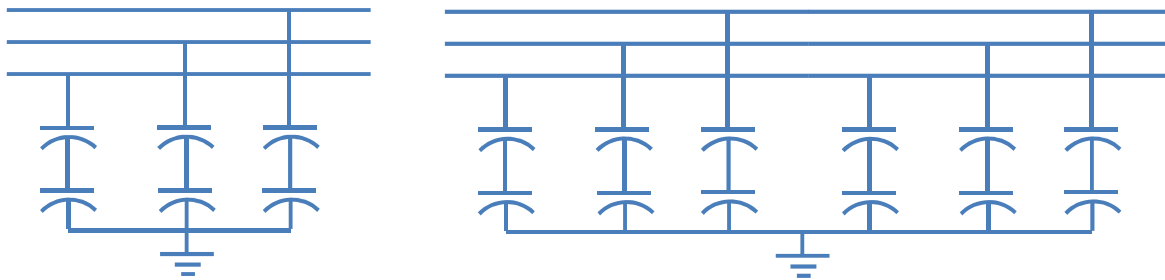

More units grounded single wye

More units grounded double wye

Figure 5. Shunt capacitor units connected in “grounded wye”

### Units connected in ungrounded wye

Common bank systems of ungrounded wye shunt capacitor bank are presented in Figure 6. Ungrounded wye units do not allow zero sequence currents, third harmonic currents, or big capacitor discharge currents during system ground failures to flow. Another benefit is that over-voltages coming out at the CT secondary sides are not as high as in the situation of grounded arrangements. Nevertheless, the neutral needs to be insulated for full line voltage since it is instantly at phase potential when the shunt

capacitor bank is turned on or when one capacitor element breaks down in a bank set up with an individual group of units. For units above 15kV this may be costly.

- Multiple units connected in series phase to neutral - single wye arrangement

Shunt capacitor bank units with external fuses, internal fuses, or no fuses can be utilized to form the bank. For unbalance protection systems that are sensitive to system voltage unbalance, either the unbalance protection time delay needs to be set sufficiently long enough for the line protections to remove the ground failures or the capacitor bank may be granted to trip a system ground fault.

- Multiple units connected in series phase to neutral-double wye. Once a capacitor bank gets too big for the maximum 4650 kvar per group the shunt capacitor bank may be divided into two wye parts. Once the two neutrals are not grounded, the bank has some of the features of the ungrounded single-wye shunt capacitor bank. These two neutrals may be linked together through a current transformer or a voltage transformer. Same like for any ungrounded wye bank, the neutral current transformers should be insulated from ground for full line-to-ground voltage. Same applies to the phase terminals.

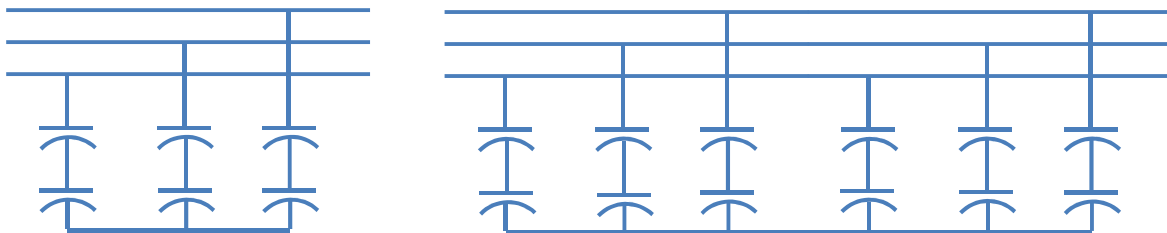

More units ungrounded single wye

More units ungrounded double wye

Figure 6. Shunt capacitor units connected in ungrounded wye

### Shunt capacitor units connected in delta arrangement

Shunt capacitor bank units that are connected in delta arrangement are typically utilized only at distributions voltages and are set with a single series group of capacitors rated

at line-to-line voltage. With only one series group of units no overvoltage happens across the staying capacitor units from the isolation of a failed capacitor unit. Hence, unbalance detecting is not needed for protection.

### H arrangement

Few bigger shunt capacitor bank units use an H arrangement in each phase with a current transformer linked between the two legs to cross compare the current down each leg. As long as all capacitors are fine, no current will go through the current transformer. If capacitors fuse trips, current will go through the current transformer. This bridge arrangement can be very sensitive. This configuration is utilized on big units with many shunt capacitor bank units connected in parallel.

### Protection of the capacitor banks

The protection of shunt capacitor banks includes:

- Protection of the shunt capacitor bank against failures happening within the shunt capacitor bank involving those inside the shunt capacitor bank unit
- Protection of the shunt capacitor bank against system disturbances and failures. The adopted protection scheme for a shunt capacitor bank depends on bank arrangement, whether or not the shunt capacitor bank unit is grounded and the system grounding.

### Shunt capacitor bank unit unbalance protection

The protection of shunt capacitor units against internal failures includes protective equipment in a coordinated system. Commonly, the protective devices found in a shunt capacitor bank for internal failures are: separate fuses, unbalance protection to give alarm and overcurrent devices for bank failure protection.

Removal of broken down capacitor element by its fuse ends in increasing the voltage

across the left over elements which causes an unbalance within the bank. A permanent overvoltage, higher than 10%, on any element shall be stopped by means of protective relays that disconnect the bank.

Unbalance protection normally senses changes associated with the failure of a capacitor element or unit and removes the bank from service when the resulting overvoltage becomes excessive on the remaining healthy capacitor units.

Unbalance protection typically delivers the primary protection for arcing failures within a shunt capacitor bank and other irregularities that may harm shunt capacitor bank unit. Arcing failures may induce significant damage in a small fraction of a second. The unbalance protection should have the lowest possible, intentional detainment in order to derogate the amount of harm to the shunt capacitor bank in the case of external arcing.

In most shunt capacitor banks units an external arc inside the capacitor bank does not end in enough change in the phase current to function the primary failure protection (typically an overcurrent relay). Sensitivity demands for proper shunt capacitor bank protection for this condition may be very requiring, especially for shunt capacitor banks with many series arrangements. The requirement for sensitive led to development of unbalance protection scheme in which particular voltages or currents arguments of the shunt capacitor bank are observed and cross compared to the bank balance circumstances. Shunt capacitor bank unbalance protection is given in many different forms, which depends on the capacitor bank configuration and grounding method. A number of unbalance protection systems are utilized for internally fused, externally fused, fuseless, or unfused shunt capacitor banks.

### **Shunt capacitor bank element failure mode**

For an effective unbalance protection it is crucial to comprehend the break down mode of the shunt capacitor element. In externally fused, fuseless or unfused capacitor banks, the broken down element can is short-circuited by the weld that normally happens at the point of fault (the element breaks down short-circuited). This short circuit leaves out of

operation the complete group of elements, raising the voltage on the remaining shunt capacitor bank groups. Few capacitor elements collapses may happen before the external fuse takes out the complete unit. The external fuse will function once a shunt capacitor bank unit becomes basically short circuited, isolating the broken unit.

Shunt capacitor banks that are internally fused have separately fused capacitor elements that are disjointed when an element failure happens. The danger of sequential failures is minimized since the fuse will set apart the broken element within a few cycles. The level of unbalance brought in by an element fault is less than that which happens with units that are externally fused (since the quantity of capacitance taken away by blown fuse is lower) and therefore a more sensitive unbalance protection system is needed when units with internal fuses are used.

### **Protection schemes with ambiguous indication**

A mix of capacitor elements faults may give ambiguous indications on the circumstances of the shunt capacitor bank. For example, during steady state service, negligible current goes through the current transformer between the neutrals of an ungrounded wye-wye shunt capacitor bank for a balanced bank, and this consideration is accurate. Nevertheless, the paltry current may go through current transformer if same number of elements is taken away from the same phase on both sides of the shunt capacitor bank as displayed in Figure 7. This situation is unwanted, and the indication is evidently ambiguous.

Where ambiguous indication is an option, it is worthy to have a sensitive alarm to minimize the potential of prolonger service with calling off faults that lead in extending, unseen over-voltages on the staying elements. It may also be suitable to set the trip level established on guessed number of calling off faults in order to cut down the danger of subjecting shunt capacitor units to damaging voltages and requiring fuses to service above their voltage capacity when calling off faults happen.

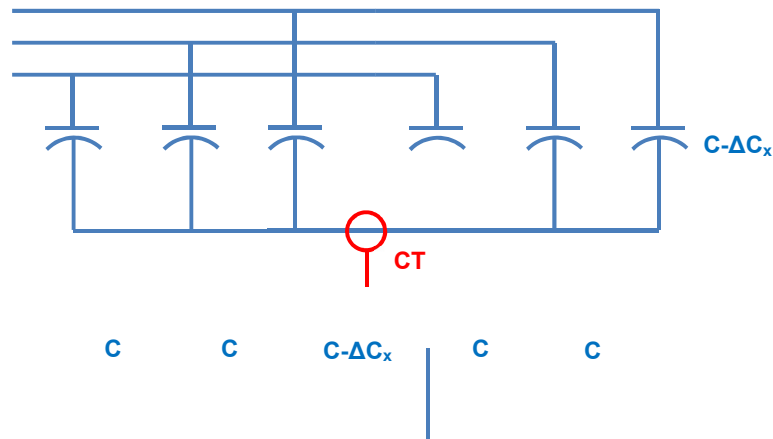

Figure 7. Compensating faults in the same phase lead to no unbalance signal

### Faults that are undetectable

For specific shunt capacitor bank arrangements some failures within the shunt capacitor bank will not induce an unbalance signal and will remain unnoticed. For instance:

- rack-to-rack failures for shunt capacitor units with two series groups linked phase-over-phase and using neutral voltage or current for unbalance protection; and,
- rack-to-rack faults for specific H-bridge arrangements.

### Inherent unbalance and system unbalance

In reality, the unbalance detected by the unbalance relay is the outcome of the tripping of separate capacitor elements and the inherent system and shunt capacitor bank unbalances. The primary unbalance that appears on all shunt capacitor bank arrangements is due to system voltage unbalance and capacitor production margin. Secondary unbalance mistakes are brought in by detecting equipment margins and change and by relative variations in capacitance due to deviations in shunt capacitor

unit temperatures in the shunt capacitor bank. The underlying unbalance mistake may be in the direction to stop unbalance relay functioning, or to induce a delusive functioning.

If the inherent unbalance mistake reaches 50% of the alarm value, compensation should be allowed for in order to properly alarm for the fault of one element as defined. In some situations, a different shunt capacitor bank arrangement can enhance the sensitivity without providing compensation. For instance, a wye connected shunt capacitor bank can be divided into a wye-wye shunt capacitor bank, thereby duplicating the sensitivity of the protection and extinguishing the system voltage unbalance result.

A neutral unbalance protection system with compensation for inherent unbalance is typically needed for very big units. The neutral unbalance signal generated by the loss of one or two separate capacitor elements is insignificant in comparison to the inherent unbalance and the latter can no longer be conceived negligible. Unbalance compensation needs to be utilized if the inherent unbalance surpasses one half of the desired value. Harmonic voltages and currents can affect the function of the unbalance relay unless power frequency band-pass or other appropriate filtering is supplied.

### **Considerations of an unbalance trip relays**

The time detainment of the unbalance relay trip needs to be minimized to cut down harm from an arcing failure within the bank arrangement and forestall exposure of the left shunt capacitor elements to overvoltage circumstances outside their allowed boundaries.

The unbalance trip relay needs to have sufficient time detainment to avert false functioning due to inrush, system ground failures, switching of nearby device, and non-simultaneous pole function of the energizing switch. For majority of usages, 0.1s should be enough. For unbalance relaying schemes that would function on a system voltage unbalance, a detainment somewhat longer than the upstream protection failure clearing



time is needed to avert tripping due to a system failure. Longer detainments raise the possibility of catastrophic shunt capacitor bank faults.

With grounded capacitor elements, the fault of one pole of the shunt capacitor bank switching equipment or a single phasing from a blown shunt capacitor bank fuse will let zero sequence currents to go in system ground relays. Shunt capacitor bank relaying, including the operating time of the switching equipment, needs to be interconnected with the functioning of the system ground relays to avert tripping system load. The unbalance trip relay arrangement needs to have a lockout option to advert accidental closedown of the shunt capacitor bank switching element if an unbalance trip has happened.

### **Considerations of an unbalance alarm relays**

To permit the impacts of inherent unbalance within the shunt capacitor bank, the unbalance relay alarm needs to be set to function at about one-half the level of the unbalance signal defined by the computed alarm terms that are based on an idealized shunt capacitor bank. The alarm needs to have adequate time detainment to overrule external disturbances.

### **Unbalance protection for ungrounded single wye elements**

The merest system to sense unbalance in single ungrounded Wye elements is to evaluate the shunt capacitor bank neutral or zero sequence voltage. If the shunt capacitor bank is balanced and the system voltage is balance the neutral voltage will be zero. A variation in any phase of the shunt capacitor bank will lead to neutral or zero sequence voltage.

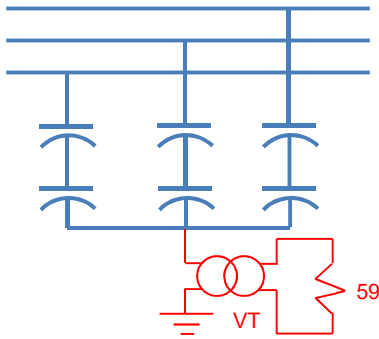

Figure 8.a.

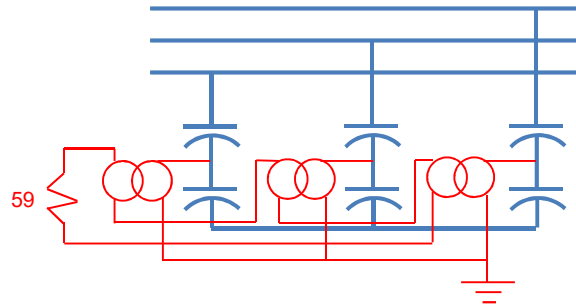

Figure 8.b.

System that evaluates the voltage between capacitor neutral and ground using a VT and an overvoltage relay with 3th harmonic filter is displayed in Figure 8 (a). It is fairly straightforward but endures in the case of system voltage unbalances and inherent unbalances. The voltage-sensing equipment is typically a voltage transformer but it could also be a capacitive potential element or resistive potential element. The voltage-sensing element needs to be chosen for the lowest voltage proportion attainable, while still being in a position to resist transient and uninterrupted overvoltage circumstances to get the maximum unbalance detection sensitivity. Nevertheless, a voltage transformer applied for this purpose needs to be sized for full system voltage since the neutral voltage can under certain circumstances increase to as high as 2.5 per unit during switching.

An equivalent zero sequence component that eradicate the system unbalances can be gained using three voltage-sensing elements with their high side voltage wye-connected from line to ground, and the secondary side linked in a broken delta arrangement. The voltage source VTs can be at a tap in the shunt capacitor bank or utilized the VTs of the shunt capacitor bank bus.

Neutral unbalance relay protection arrangement for an ungrounded wye shunt capacitor bank, utilizing three phase-to-neutral voltage transformers with their secondary sides linked in broken delta arrangement to an overvoltage relay is displayed in Figure 8 (b). Comparing to the arrangement in Figure 8(a), this arrangement has the benefit of not being sensitive to system voltage unbalance. Also, the unbalance voltage heading to

the overvoltage relay is three times the neutral voltage as found from Figure 8(a). For the same voltage transformer proportion, there is a benefit of three in sensitivity over the single neutral-to-ground voltage transformer arrangement. The voltage transformers need to be sized for line-to-line voltage.

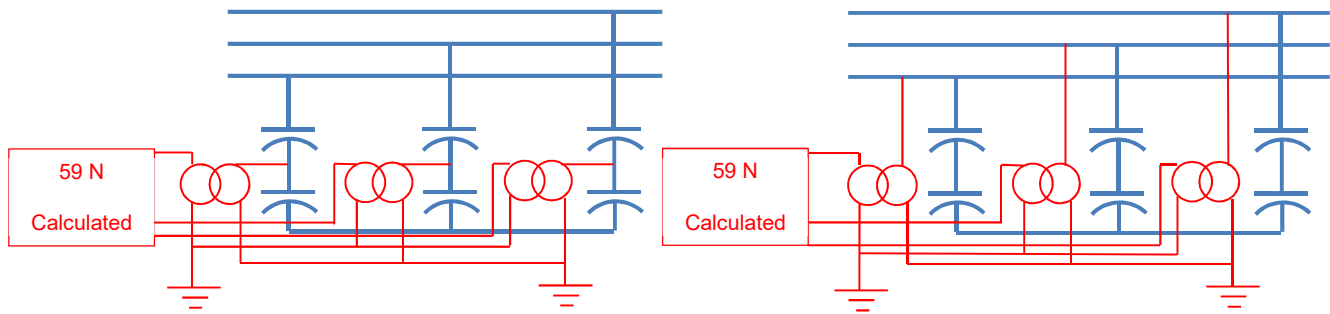

Figure 9.a.

Figure 9.b.

Advanced digital protection relays can compute the zero sequence voltage from the phase voltages as displayed in Figure 9 (a), ridding of the requirement of extra auxiliary VTs to get the zero sequence voltage. Fig 9 (b) presents the same method but utilizing the VTs on the shunt capacitor bank bus. Even though arrangements presented in Figure 8(b), 9(a) and 9(b) get rid of system unbalances, they do not get rid of the inherent capacitor unbalance. Protection arrangement that eliminates the system unbalance and even up for the inherent capacitor unbalance is presented in Figure 10. It is a modification of the voltage differential arrangement for grounded elements. The most beneficial system to get rid of the system unbalance is to divide the shunt capacitor banks in two Wyes; nevertheless, it may not be always feasible or suitable. The system unbalance comes out as a zero sequence voltage both at the shunt capacitor bank terminal and at the shunt capacitor bank neutral. The shunt capacitor bank terminal zero sequence portion is gained from 3 line VTs with their high voltage side connected in Wye and their secondary side linked in broken delta. The deviation voltage between the neutral unbalance signal due to system unbalance and the computed zero sequence from the terminal VTs will be evened up for all circumstances of system unbalance. The left over error coming out at the neutral due to producers' capacitor margin is then evened up for by means of a phase shifter.

### Unbalance protection for ungrounded double wye shunt capacitor banks

Ungrounded shunt capacitor bank elements can be divided into two equal elements. This bank arrangement inherently evens up for system voltage unbalances; nevertheless, the impacts of producers' capacitor margin will impact relay function unless steps are taken to even up for this error.

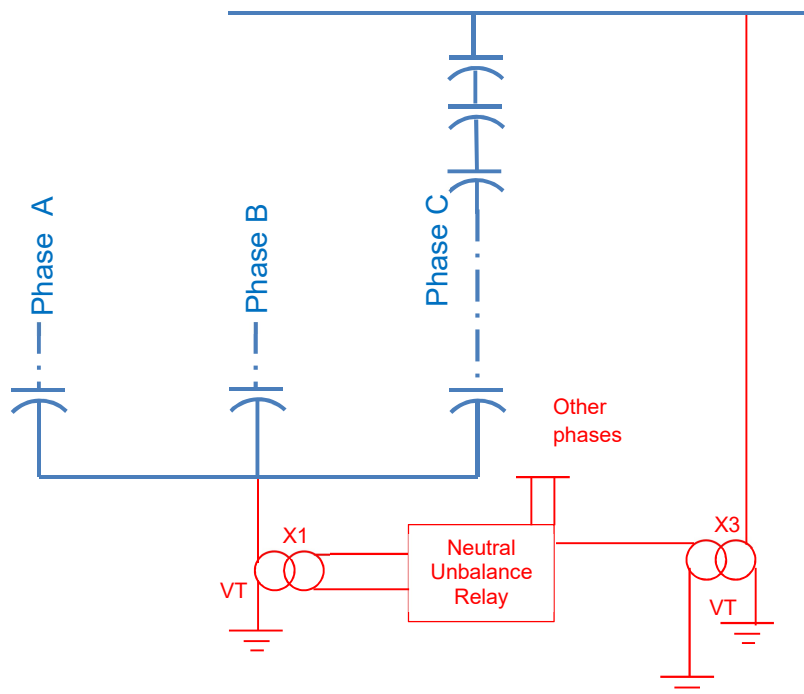

Figure 10. Compensated neutral voltage unbalance system

Three arrangements of supplying unbalance protection for double wye ungrounded elements are shown in Figure 11(a) that utilizes current transformer on the connection of the two neutrals and an overcurrent relay (or a shunt and a voltage relay). Arrangement presented in the Figure 11(b) utilizes a voltage transformer linked between the two neutrals and an overvoltage relay. The impact of system voltage unbalances are averted by both arrangements and both are untouched by third harmonic currents or voltages once they are balanced. The current transformer or voltage transformer needs to be sized for system voltage.

The neutral current is one-half of that of a single grounded shunt capacitor bank of the

## Shunt Capacitor Bank Design and Protection Basics

same rating. Nevertheless, the current transformer ratio and relay size may be picked out for the hoped sensitivity since they are not subjected to switching surge currents or single-phase currents as they are in the grounded neutral arrangement.

Even though a low-ratio voltage transformer would be worthy, a voltage transformer sized for system voltage is needed for the ungrounded neutral. Hence, a high turns ratio should be consented.

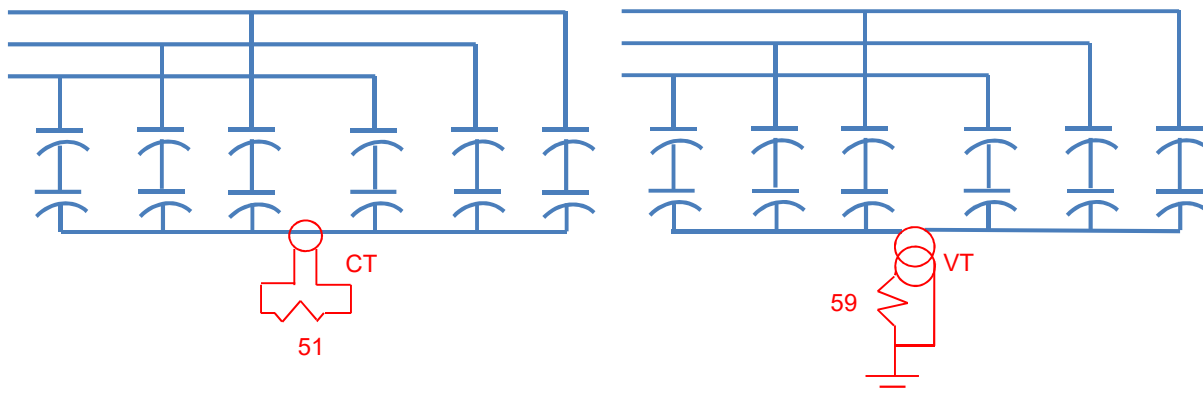

Figure 11.a.

Figure 11.b.

Arrangement where the neutrals of the two capacitor parts are ungrounded but linked together is shown in Figure 12. A voltage transformer, or potential device, is utilized to evaluate the voltage between the capacitor bank neutral and ground. The relay needs to have a harmonic filter.

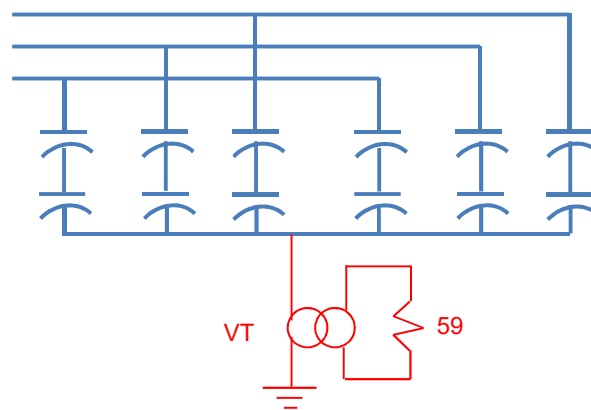

Figure 12.

### Unbalance protection arrangement for grounded single wye elements

An unbalance in the shunt capacitor bank will induce current to flow in the neutral. Protection arrangement founded on a current transformer used on the link between the shunt capacitor bank neutral and ground is shown in Figure 13 (a). This current transformer has unusual high overvoltage and current demands. The ratio is chosen to provide both decent overcurrent capability and appropriate signal for the protection.

The current transformer output has a burden resistor and a sensitive voltage protection relay. Due to the existence of harmonic currents (especially the third, a zero sequence harmonic that goes through the neutral-to-ground link), the protection relay needs to be tuned to cut down its sensitivity to frequencies other than the power frequency.

The voltage across the burden resistor is in phase with the neutral-to-ground current. This neutral-to-ground current is the vector amount of the three-phase currents, which are  $90^\circ$  out of the phase with the system phase-to-ground voltages. This arrangement may be counterbalanced for power system voltage unbalances, by taking into the account the  $90^\circ$  phase shift, and is not uncommonly suitable for very big capacitor elements needing very sensitive adjustments.

Each time the shunt capacitor bank is switched on, momentary unbalanced capacitor charging currents will diffuse in the phases and in the capacitor neutral. In the case parallel shunt capacitor bank is already in function these current can be on the order of thousands Amps making the relay to maloperate and CT to break.

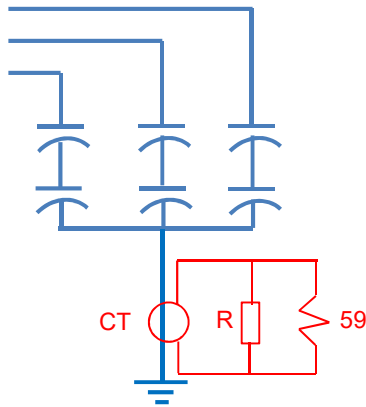

Figure 13.a.

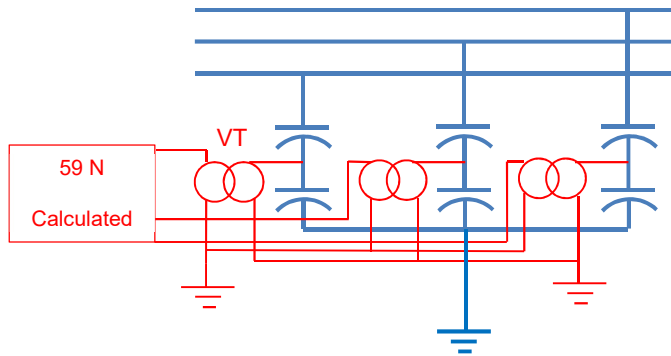

Figure 13.b.

An unbalance voltage protection arrangement for single grounded wye linked shunt capacitor banks utilizing capacitor tap point voltages is shown in Figure 13 (b). An unbalance in the shunt capacitor bank will induce an unbalance in the voltages at the tap point of the three phases. The protection arrangement comprises of a voltage sensing element linked between the capacitor intermediate point and ground on each phase. A time detainment voltage relay with third harmonic filter is linked to the broken delta secondary sides. Modern digital protection relays utilize the computed zero sequence voltage instead as presented in Figure 13(b).

### Unbalance protection for grounded double wye elements

Arrangement in which a current transformer is connected on each neutral of the two parts of a double wye shunt capacitor bank is shown in Figure 14. The neutrals are linked to a common ground. The current transformer secondary sides are cross-connected to an overcurrent relay so that the protection relay is insensitive to any outside impact that affects both parts of the shunt capacitor bank in the same way. The current transformers can be subjected to switching transient currents and, hence, surge protection is needed. They should be rated for single-phase load currents if feasible. (Optionally, the links from neutral to ground from the two wyes may be in different directions through a single-window current transformer).

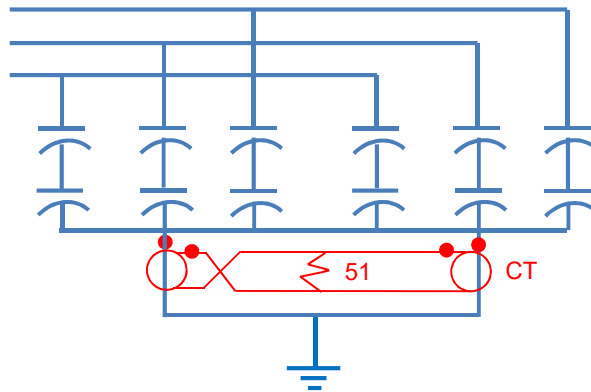

Figure 14.

### Voltage differential protection arrangement for grounded wye elements

On big shunt capacitor banks with huge amount of capacitor elements, it is very hard to sense the loss of 1 or 2 shunt capacitor elements as the signal generated by the unbalance is buried in the inherent shunt capacitor bank unbalance. The voltage differential gives a very sensitive and efficient way to counterbalance for both system and inherent shunt capacitor bank unbalances in grounded wye capacitor elements. The voltage differential arrangement for a single wye-connected shunt capacitor bank is presented in Figure 15. The voltage differential arrangement for a double wye connected bank is shown in Figure 16.

The arrangement utilizes two voltage transformers per phase: one linked to a tap on the shunt capacitor bank; the other, at the bank bus for single wye elements; or, for double wye elements, at a similar tap on the second bank. By cross comparing the voltages of both VTs, a signal responsive to the loss of single capacitor elements or units is gained.

The shunt capacitor bank tap voltage is found by linking a voltage-sensing element across the ground end parallel group (or groups) of capacitors. This may be a midpoint tap, where the voltage is evaluated between the midpoint of the phase and ground. Optionally, the tap voltage may be evaluated across low-voltage capacitors (that is, a capacitive shunt) at the neutral end of the phase.



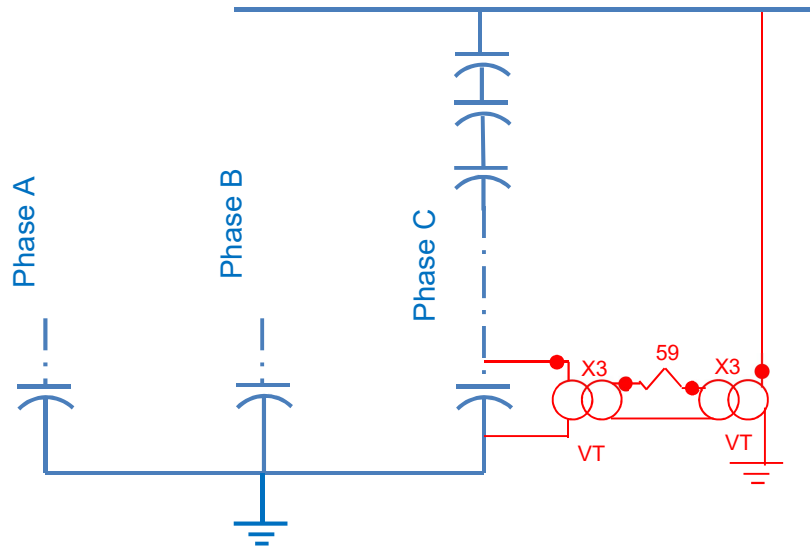

Figure 15. Voltage differential scheme for grounded single wye shunt capacitor bank

For commissioning, after testing that all shunt capacitors are fine and no fuses have functioned, the voltage levels are initially adapted to be the same. The initial difference signal between the shunt capacitor bank tap voltage and the bus voltage (for single wye elements) signals is zero, and the shunt capacitor margin and initial system voltage unbalance is counterbalanced. If the system voltage unbalance should change, the protection relay system is still counterbalanced because a given percent change in bus voltage leads to the same percent variation on the capacitor bank tap. Any later voltage deviation between capacitor tap voltage and bus voltage will be due to unbalances induced by loss of capacitor elements within that specific phase. For double wye elements, the tap voltage is cross-compared the other wye tap voltage.

Modern digital protection relay dynamically counterbalance secondary errors brought in by sensing element change and temperature deviations between capacitor elements within the shunt capacitor bank. If the shunt capacitor bank is tapped at the midpoint the sensitivity is the same for faults within and outside the tapped part. If the shunt capacitor bank is tapped below (above) the midpoint, the sensitivity for faults within the tapped part will be higher (lower) than for faults outside the tap part. This deviation may make trouble in accomplishing an adequate relay setting. The sensitivity for a midpoint tap and a tap across low-voltage capacitors at the neutral end of the phase is the same.

Tapping across the bottom series groups or a midpoint tap is not suitable for fuseless shunt capacitor units with more strings since the strings are not linked to each other at the tap point. Tapping across the low-voltage capacitors is appropriate for fuseless shunt capacitor elements.

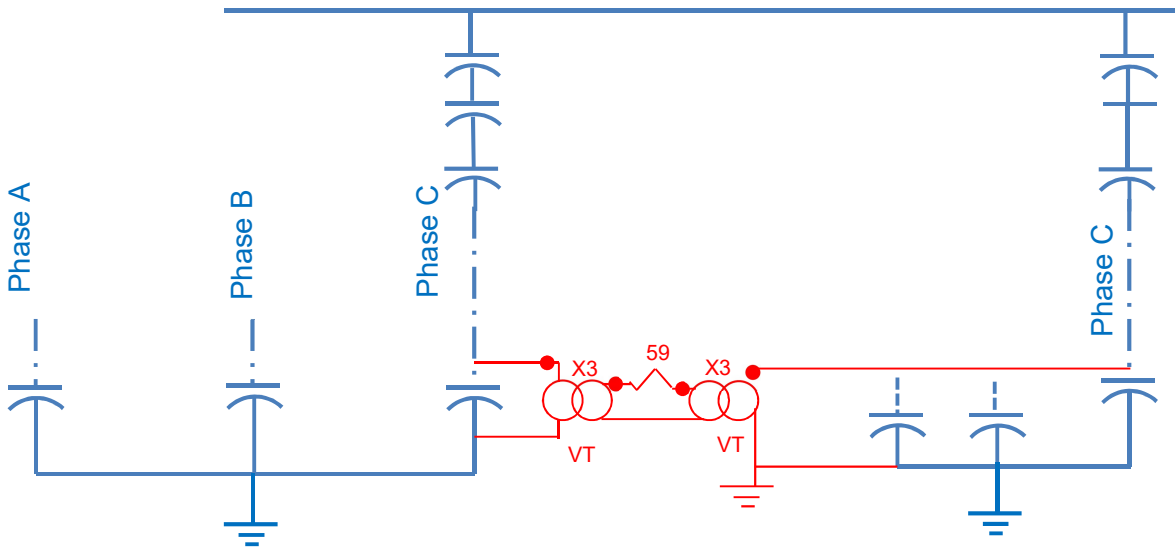

Figure 16. Voltage differential arrangement for grounded double wye shunt capacitor bank

### **Protection against internal bank failures**

There are specific failures within the shunt capacitor bank that the unbalance protection will not sense or other ways are needed for its clearance.

### **Mid-rack phase to phase failures**

Generally, individual phases of a shunt capacitor bank are made on different structures where phase to phase failures are improbable. Nevertheless, conceive an ungrounded single wye shunt capacitor bank with two series groups per phase where all three phases are put upon a single steel structure. A mid-rack failure between 2 phases as

presented in Figure 17 can happen and will go undiscovered. This failure does not induce an unbalance of the neutral voltage (or neutral current if grounded) as the healthy voltage is counter balance by the 2 other faulty phase voltages.

The most effective protection for mid-rack phase to phase failures is the negative sequence current. Tripping shall be detained to coordinate with other protection relays in the system.

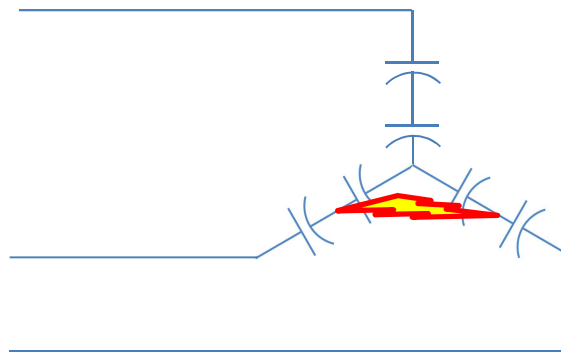

Figure 17. Mid-rack failure

### **Failures on the capacitor bank bus**

Time overcurrent protection relays for phase and ground are needed to supply protection for phase and ground failures on the connecting feeder (or bus) between the bank bus and the first capacitor element.

Directional overcurrent protection relays looking into the shunt capacitor bank are favoured to avert maloperation of the TOC 51N for unbalance system failures.

### **Protection of the shunt capacitor banks against system disturbances and failures**

#### **System overvoltage protection**

The shunt capacitor bank may be subjected to over voltages leading from abnormal system operating conditions. If the system voltage surpasses the shunt capacitor bank capability the bank needs to be taken out from function. The removal of the shunt

capacitor bank brings down the voltage in the locality of the shunt capacitor bank abbreviating the overvoltage on other system elements. Time delayed or inverse time delayed phase overvoltage protection relays are utilized.

### Protection relays for bank closing check

Once disconnected from the system a shunt capacitor bank cannot be put back into the service instantly due to the electrical charge present within the shunt capacitor elements, otherwise catastrophic harm to the circuit breaker or switch can happen. To speed up the discharge of the shunt capacitor bank, every shunt capacitor unit has a resistor to discharge the trapped charges within 5min. Under voltage or undercurrent protection relays with timers are utilized to sense the shunt capacitor bank going out of function and forestall closing the breaker until the set time has passed.

### Conclusions

The protection of shunt capacitor bank units uses straightforward, well known relay protection methods such as overvoltage, over-currents. Nevertheless, it needs the protection engineer with a solid apprehension of the shunt capacitor bank units, its scheme and shunt capacitor bank design problems before embarking in its protection.

Unbalance is the most crucial protection in a shunt capacitor bank, as it gives fast and efficient protection to insure a long and reliable life for the bank. To achieve its goal, unbalance protection needs high degree of sensitivity that might be hard to accomplish. The main objectives for the design of a shunt capacitor bank and its associated protection schemes have been presented in the course. The latest "IEEE Guide for the Protection of Shunt Capacitors Units" needs to be the leading standard when carrying out a protection arrangement to a shunt capacitor bank.