



## Power System Short Circuit Current Studies

**Course Number:** EE-05-901

**PDH:** 5

**Approved for:** AK, AL, AR, FL, GA, IA, IL, IN, KS, KY, LA, MD, ME, MI, MN, MO, MS, MT, NC, ND, NE, NH, NJ, NM, NV, NY, OH, OK, OR, PA, SC, SD, TN, TX, UT, VA, VT, WI, WV, and WY

New Jersey Professional Competency Approval #24GP00025600

North Carolina Approved Sponsor #S-0695

Maryland Approved Provider of Continuing Professional Competency

Indiana Continuing Education Provider #CE21800088

Florida Provider #0009553 License #868

NYSED Sponsor #274

This document is the course text. You may review this material at your leisure before or after you purchase the course. In order to obtain credit for this course, complete the following steps:

- 1) Log in to My Account and purchase the course. If you don't have an account, go to New User to create an account.
- 2) After the course has been purchased, review the technical material and then complete the quiz at your convenience.
- 3) A Certificate of Completion is available once you pass the exam (70% or greater). If a passing grade is not obtained, you may take the quiz as many times as necessary until a passing grade is obtained (up to one year from the purchase date).

If you have any questions or technical difficulties, please call (508) 298-4787 or email us at [admin@PDH-Pro.com](mailto:admin@PDH-Pro.com).

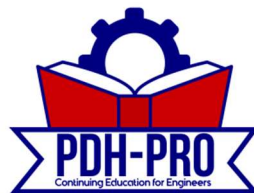

# Power System Short Circuit Current Studies

## Introduction and Scope

Electrical power systems are systems composed of a wide range of power equipment used for generating, transmitting, and distributing electrical power to consumers. Complexity of these systems indicates that breakdowns and faults are unavoidable, no matter how carefully these systems have been designed. Electrical system can be designed with zero failure rate is, however that is economically unjustifiable. From the perspective of short-circuit analysis, system faults manifest themselves as insulation breakdowns. These breakdowns lead to one or more phenomena:

- Undesirable power flow
- Currents of excessive magnitudes that usually cause equipment damage
- Excessive over-voltages
- Voltage depressions
- Cause conditions that could harm personnel

Short circuits cannot always be prevented so system designers can only try to mitigate their potentially damaging effects. Electrical system should be designed so that the occurrence of the short circuit becomes minimal. In the case short circuit occurs, mitigating its effects consists of:

- managing the magnitude of the undesirable fault currents,
- Isolating the smallest possible portion of the system around the faulted area in order to retain service to the rest of the system.

One of the major parts of system protection is orientated towards short-circuit detection. Interrupting equipment at all voltage levels that is capable of withstanding the fault currents and isolating the faulted area requires considerable investments. Therefore, main reasons for performing short-circuit studies are as follows:

- Verification of the adequacy of existing interrupting equipment.
- Defining system protective device settings and that is done by quantities that describe the system under fault conditions.
- Defining effects of the fault currents on various system components such as cables, overhead lines, buses, transformers, capacitor banks and reactors during the time the fault persists. Mechanical stresses from the resulting fault currents

are compared with the corresponding short-term withstand capabilities of the system equipment.

- Assessment of the effect that different kinds of short circuits of varying severity may have on the overall system voltage profile. These calculations identify areas in the system for which faults can result in unacceptable voltage depressions.
- Design and sizing of system layout, neutral grounding, and substation grounding.
- Compliance with codes and regulations governing system design and operation.

### Extent and requirements of short-circuit studies

Short circuit studies are as necessary for any power system as other fundamental system studies such as power flow studies, transient stability studies, harmonic analysis studies, etc. Short-circuit studies can be performed at the planning stage in order to help finalize the single line diagrams, determine and set voltage levels, and network equipment such as cables, transformers, and conductors. For existing systems, fault studies are necessary in the cases of added generation, installation of extra rotating loads, network topology modifications, rearrangement of protection equipment, verification of the adequacy of existing breakers, relocation of already acquired switchgear, etc. Short-circuit studies can also be performed in order to duplicate the reasons and system conditions that led to the system's failure.

The requirements of a short-circuit study will depend on the set objectives. These objectives will dictate what type of short-circuit analysis is required. The amount of data required will also depend on the extent and the nature of the study. The majority of short-circuit studies in industrial and commercial power systems address one or more of the following four kinds of short circuits:

- Three-phase fault. May or may not involve ground. All three phases shorted together.
- Line-to-line fault. Any two phases shorted together.
- Double line-to-ground fault. Any two phases connected together and then to ground.
- Single line-to-ground fault. Any one, but only one, phase shorted to ground.

Fault types are graphically presented in figures below.

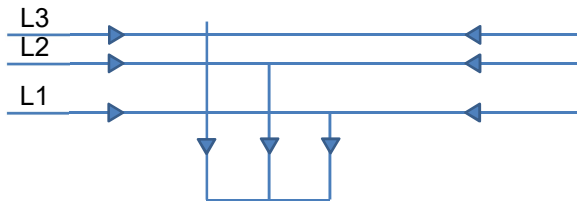

Three Phase Fault

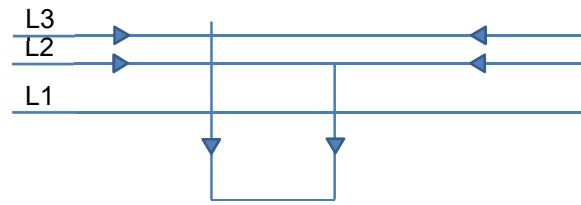

Line to Line Fault

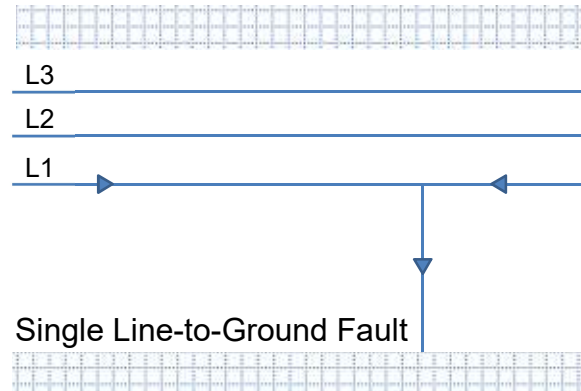
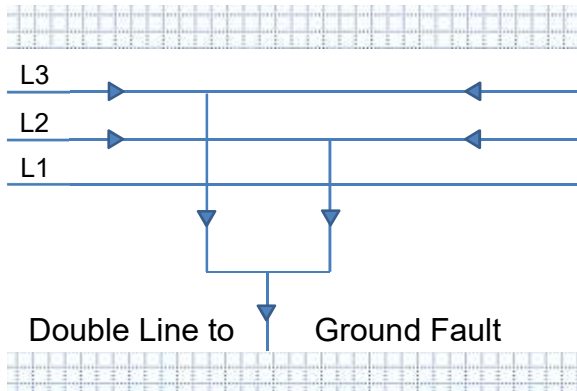

These types of short circuits are also referred to as “shunt faults,” since all four are associated with fault currents and MVA flows diverted to paths different from the pre fault “series” ones. Three-phase short circuits often turn out to be the most severe of all. It is thus customary to perform only three phase-fault simulations when searching for the maximum possible magnitudes of fault currents. However, exceptions exist. For instance, single line-to-ground short-circuit currents can exceed three-phase short-circuit current levels when they occur in the electrical vicinity of

- A solidly grounded synchronous machine
- The solidly grounded wye side of a delta-wye transformer of the three-phase core (three-leg) design
- The grounded wye side of a delta-wye autotransformer
- The grounded wye, grounded wye, delta-tertiary, three-winding transformer

For electrical systems where any or more of the above conditions exist, it is advisable to perform a single line-to-ground fault simulation. Line-to-line or double line-to-ground fault studies may also be required for protective device coordination requirements. Also, since only one phase of the line-to-ground fault can experience higher interrupting requirements, the three-phase fault will still contain more energy because all three phases will need the same interrupting requirements. Other types of fault conditions that

may be of interest include the “series faults” and they refer to one of the following types of system unbalances:

- One line open. Any one of the three phases may be open.
- Two lines open. Any two of the three phases may be open.
- Unequal impedances. Unbalanced line impedance discontinuity.

Series fault types are graphically presented in figures below.

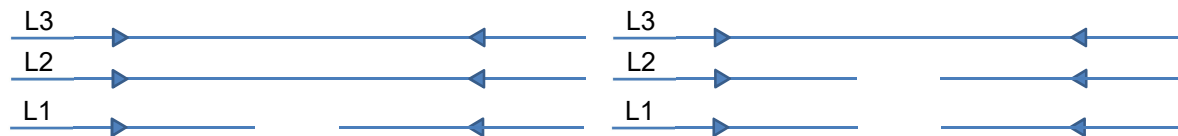

One line open

Two lines open



The term “series faults” is used because these faults are associated with a redistribution of the pre-fault load current. Series faults are of interest when assessing the effects of snapped overhead phase wires, failures of cable joints, blown fuses, failure of breakers to open all poles, inadvertent breaker energization across one or two poles and other situations that result in the flow of unbalanced currents.

## System modelling and computational techniques

### AC and DC decrement

Physical phenomena that determine the magnitude and duration of the short-circuit currents are:

- The operation of the rotating machinery in the electrical system
- The electrical proximity of the rotating machinery to the short-circuit location
- The fact that the pre-fault system currents cannot change instantaneously, due to the significant system inductance

The first two can be conceptually linked to the AC decrement, while the third, to the DC decrement.

## AC decrement and rotating machinery

AC decrement is determined by the fact that the magnetic flux inside the windings of the rotating machinery cannot change momentarily. From that reason synchronous machines, under fault conditions, show different flux variation patterns as compared to induction machines. The flux dynamics dictate that short-circuit current decays with time until a steady-state value is reached. Machine software models, present rotating machines as constant voltages behind time-varying impedances.

For modelling purposes, these impedances increase in magnitude from the minimum post fault subtransient value  $X_d''$ , to the relatively higher transient value  $X_d'$ , and finally reach the even higher steady-state value  $X_d$ , assuming that the fault is not cleared before. The rate of increase of machine reactance is different for synchronous generators/motors and induction motors. Rate of increase for induction motors is higher than for synchronous generators. This modelling approach is fundamental in properly determining the symmetrical RMS values of the short-circuit currents furnished by the rotating equipment for a short circuit anywhere in the system.

### Fault current DC decrement and system impedances

Fault current DC decrement is also impacted by the fact that because the current existing in the system before the fault, cannot change instantaneously, a considerable unidirectional component may exist in the fault current which actually depends on the exact occurrence of the short circuit. This unidirectional component of the fault current is often referred to as DC current offset as it reduces with time exponentially. The rate of decay is related to the system total reactance and resistance. Although this decay is quick, the DC current component could last enough time to be detected by the protective relay equipment, particularly when fast fault clearing is very needed to maintain system stability or prevent the damaging effects of the fault currents.

Short circuit currents cleared by circuit breakers must consider this unidirectional component, especially for shorter interrupting periods. Same DC component is important when verifying the capability of a circuit breaker to reclose against or withstand fault currents. Fault currents containing high current DC offsets, usually present no zero crossings in the first several cycles right after fault introduction and are especially burdensome to the circuit breakers of large generators.

## Modelling requirements of the power system

Modern power systems are usually system comprised of more generators, with many motors and usually more than one generator. They are interlinked using other

equipment like transformers, overhead lines and cables. Also there is usually one or more location at which local, smaller power system is connected to a larger electrical grid. These locations are referred to as “point of common coupling”. The main goal of the short-circuit study is to calculate the short-circuit currents and voltages at various location throughout the system. Fault currents have dynamic aspect that is necessary to associate calculated short circuit currents to a specific moment in time from the onset of the short circuit. AC current decrement assessment is used to properly determine the symmetrical RMS values of the short circuit currents, while DC decrement calculations provide the necessary DC current component of the fault current, hence affording a correct approximation of the total short circuit current. The total fault current, must be used for breaker and switchgear sizing and in some specific scenarios for protective relay device coordination. Electrical system topology conditions are evenly significant because the system arrangement and electrical closeness of the rotating machinery to the fault location will influence the total order of magnitude of the fault current. It is therefore essential to come up with an electrical system model as a whole and examine it as such in an accurate and computationally convenient manner.

### **Representation of the three-phase vs. symmetrical components**

It is accustomed practice for conventional three-phase electrical systems to be interpreted on a single-phase basis. Mentioned simplification, successfully applied for power flow and transient stability studies, leans on the assumption that the electrical system is equally balanced or can be accepted to be so for practical purposes. However, electrical system modelling, on a single-phase basis is insufficient for examining processes that take into account serious system imbalances. From the short-circuit analysis point of view, three-phase fault lends itself to single-phase analysis, because the fault is balanced and asks for all three phases, presuming a balanced three-phase electrical system. Other short circuit current conditions will bring in imbalances that need the analysis the remaining unaffected two phases. There are two options to address the problem:

- Representation of the system using all three-phases. If the system is represented on a three-phase basis, the identity of all three phases is retained. The advantage of this approach is that any kind of short circuit current imbalance can be promptly assessed, including coincidental faults. Moreover, the short circuit current condition is defined with bigger flexibility, especially for arcing faults. The main disadvantages of the technique are:

- It is not convenient for manual calculations, even for small electrical systems.
- If the computer program is used, it can be data-intensive.
- Representation using symmetrical components. Analysis using symmetrical components is a method that, instead of asking for assessment of the imbalanced electrical system, provides provision for creation of three electrical subsystems, the positive, the negative, and the zero-sequence systems that are correctly connected at the short circuit point which depends on the type of the electrical system imbalance. Fault currents and voltages once they are modelled, anywhere in the network, can then be obtained by properly aggregating findings of the analysis of the three-sequence networks.

The distinguishable advantage of the approach that uses symmetrical components is that it gives provision for representing imbalanced short circuit conditions, while it still holds the conceptual simplicity of the single-phase assessment. Additional significant advantage of the symmetrical components technique is that impedances of the system equipment can be measured in the symmetrical components reference frame. This reduction is true only if the system is balanced in all three phases (excluding fault location which becomes the connection point of the sequence networks), the premise that can be entertained without bringing in considerable modelling errors for most electrical systems.

The main weakness of the method is that for complex short circuit current conditions, it may bring in more problems than it resolves. The method of symmetrical components continues the favored analytical tool for short circuit current analysis for hand and computer-based assessments.

### **Impedances of the electrical system and analysis of symmetrical components**

Theory of the symmetrical components prescribes that for a three-phase electrical system, it needs to be established for the assessment of imbalanced short circuit current conditions. The first part is the positive sequence system, that is determined by a balanced set of voltages and currents of the equal magnitude, following the phase sequence of a, b, and c.



The second part is the negative sequence system, that is similar to the positive sequence system, but is determined by a balanced set of voltages and currents with a reverse phase sequence of a, c, and b.

Lastly, the zero sequence system is defined by a group of voltages and currents that are in phase with each other and not displaced by 120 degrees, as it is the case with the other two systems. Electrical connectivity of the zero sequence system can be different from the positive and negative sequence systems. This is due to the fact that it is influenced by the power transformer winding connections and system neutral grounding, components that are not important when ascertaining the topology of the positive and the negative sequence networks.

Electrical system equipment components such as transformers, overhead lines, cables, bus bars, and static loads, under balanced system conditions can be considered as static and have the same impedances that are used for calculating positive and negative sequence currents. In principle, same components present different electrical impedances for determining the flow of zero sequence currents. Rotating electrical equipment like electrical synchronous generators and motors has different electrical impedances for all three phase sequence networks. The positive sequence electrical impedances are usually used for balanced power flow calculations. Sequence impedances must be calculated, measured, specified by the manufacturers of the equipment, or estimated based on the standard engineering practice. The zero sequence electrical impedance may not exist for particular rotating equipment which depends on the machine grounding system.

Three-phase fault analysis for the balanced systems requires only the positive sequence system components impedances  $Z_1 = (R_1 + jX_1)$ . For calculation of the line-to-line faults, negative sequence impedances  $Z_2 = (R_2 + jX_2)$  are required. For all faults involving connection to the ground, such as line-to-ground and double line-to-ground faults, the zero sequence system impedances  $Z_0 = (R_0 + jX_0)$  are required in addition to the positive and negative systems. System neutral grounding equipment components such as grounding resistors or reactors, grounding transformers constitute an inherent part of the impedance data for the zero sequence system.

Fault current AC decrement conditions prescribe that rotating electrical equipment impedances differ from the onset of the short circuit. This is applicable only to positive

sequence impedances that range from sub-transient through transient to steady-state values. The negative and zero sequence impedances for the rotating electrical equipment are considered unaltered. The same is valid for the electrical impedances of the static system components.

### **Time domain short circuit current analysis – Calculation methods**

Time-domain short circuit current assessment refers to methods that give provision for the computation of the fault currents as a function of time from the instant of the fault origin. For large electric power systems, which consist of numerous electrical machines and generators that jointly contribute to the total fault current, the contributions of many electrical machines will have to be considered concurrently. Electrical machine models were formulated that let predictions of significant accuracy be made with respect to behavior of any electrical machine for a short circuit current occurrence either at or beyond its terminals. These models are complex because they represent in detail not only the electrical machine itself but also nonlinear controllers including excitation systems and their related stabilization electronic equipment with associated nonlinearities. It can therefore be noted that the computational necessities could be colossal, because the task is cut down to simultaneously solving a huge number of differential equations. Despite its underlying power, the usage of time-domain short circuit current analysis is not widespread and is only utilized for special calculations because it is data and time intensive (required data can be at least as requiring as transient stability studies) and it asks for the special software.

### **Quasi-steady-state short circuit current assessment**

Quasi-steady-state short circuit current assessment relates to methods that interpret the system at steady state. Phasor vectors are used to present voltages across the system, currents, and electrical impedances at basic, fundamental frequency. Electrical system modelling and the resulting calculation methods are based on the premise that the electrical system and its associated electrical components can be comprised of linear models. Keeping electrical system linearity greatly simplifies the calculations. Moreover, linear algebra and the numerical advancements in matrix calculations make it possible to enforce practical computer solutions for large electrical systems. These methods have been preferred by the many industry standards.

## Industry standards for short circuit current calculations

Certain analytical techniques are defined by industry standards that adhere to specific guidelines and are specifically accommodated to address the problems of AC and DC current decay in practical multi-machine systems that are in conformity with established, practices accepted by power industry. They are also associated to and accord with adopted, existing switchgear rating structures. Typical industry standards are:

- North American ANSI
- International standard, IEC 60909

The analytical and calculation framework in the analytical processes prescribed by aforementioned standards stays algebraic and linear, and the computations are kept easily managed by hand for small systems. The extent of the information base necessities for computerized solutions is kept to a necessary maximum for the solutions to be acceptably precise. This type of analyses presents the best compromise between solution accuracy and simplicity of the simulation. The vast majority of commercial fault analysis programs fall under this category.

### ANSI standards – North American standard

IEEE standards dealing with short circuit current calculations for medium and high voltage electrical networks are:

- IEEE Standard 141-1993
- IEEE Standard C37.5-1979
- IEEE Standard 241-1990
- IEEE Standard 242-1986.
- IEEE Standard C37.010-1979

IEEE standards covering short circuit current calculations for low voltage electrical systems (below 1000 V), are:

- IEEE Standard 242-1986
- IEEE Standard 241-1990
- IEEE Standard C37.13-1990
- IEEE Standard 141-1993

Three types of fault currents are determined, depending on the time frame of interest considered from the origin of the fault, as first-cycle fault currents, also called momentary fault currents, are the currents at 1/2 cycle after fault initiation. These currents pertain to the duty circuit breakers face when “closing against” or withstanding fault currents. These currents usually contain DC offset and are computed on the assumption of no AC decay in the contributing sources. Bearing in mind that low voltage circuit breakers operate in the first cycle, their breaking ratings are compared to these currents.

### Calculated short-circuit currents and interrupting equipment

Previously discussed calculation procedures are used to perform fault calculations on industrial and commercial power systems that are comprised of several voltage levels including low, medium and high voltage systems. Fault currents that appear in the first cycles of the faults are usually used to determine interrupting requirements of low voltage fuses and breakers. These fault currents are used for calculation of the first cycle:

- First cycle currents
- Interrupting currents
- Time delayed currents

Requirements for low, medium and high voltage fault interrupting equipment. Currents that are result of short circuit current calculations are used for medium and high voltage system since they operate with time delay that is introduced by protective relaying and operating requirements. Since IEEE Standard C37.13-1990 has adopted the symmetrical rating structure and it calculates symmetrical RMS fault currents and X/R ratio can be considered as sufficient in the case calculated X/R ratio is less than the X/R ratio of the test circuit of the circuit breaker. This procedure is suitable for calculations in systems with low voltage fuse and circuit breakers as defined by IEEE Standard C37.13-1990.

It is important to mention that distinction needs to be made between ratings of medium and high voltage circuit breakers. Circuits breakers that are described in IEEE Standard C37.5-1979 and that are based on the older rating structure are assessed on the total asymmetrical short circuit current, or total fault MVA, and short circuit current calculations are bounded by minimum parting time. Newer circuit breaker rating

structure that was introduced by IEEE Standard C37.010-1979, defines breakers on their symmetrical basis. The symmetrical short circuit currents calculated using this method can be sufficient since certain degree of asymmetry is included in the rating structure of the breaker depending on the actual operational conditions and overall system X/R ratio.

IEEE Standard C37.010-1979 and IEEE Standard C37.5-1979 contain coefficients that can be applied to symmetrical RMS short circuit currents in order to get asymmetrical RMS currents. IEEE Standard C37.5-1979 defines them as total asymmetrical short circuit currents while IEEE Standard C37.010-1979 describes fault currents that are compared against circuit breaker interrupting capabilities. Mentioned coefficients are obtained from curves normalized against circuit breaker contact opening time. In order to be in line with IEC standards, ANSI C37.06-1987 introduced peak fault current to the preferred ratings as an alternative to total asymmetrical currents.

Generally, it needs to be pointed out that the most important step in the calculations of the total fault currents for the medium and high voltage circuit breakers is decision which part of the total short circuit current comes from “local” and “remote” sources in order to obtain meaningful estimate of the circuit breaker interrupting requirements. This distinction is reasoned by the fact that current from remote sources introduce slower AC current decay or do not introduce it comparing to short circuit currents from the local sources.

Remote contribution is defined in IEEE Standard C37.010-1979, IEEE Standard C37.5-1979, IEEE Standard 141-1993 and IEEE Standard 242-1986 as the current that is produced by the generators that:

- Is located two or more transformations away from the point of the fault
- Has a per unit  $X''_d$  that is 1.5 times less than the per unit external reactance on a common MVA base

## IEC 60909 - International standard

Standard IEC 60909 (published in 1988) distinguishes four duty types resulting in four different calculated short circuit currents:

- The initial short-circuit current  $I_k''$
- The peak short-circuit current  $I_p$
- The breaking short-circuit current  $I_b$
- The steady-state fault current  $I_k$

Although, the breaking and steady-state short circuit currents are in principal similar to the interrupting and time-delayed short circuit currents, respectively, the peak short circuit currents are the maximum fault currents reached during the first cycle from a beginning of a fault's and are importantly different from the first-cycle fault currents described in IEEE standards, which are total asymmetrical RMS short circuit currents. The initial short-circuit current is determined as the symmetrical RMS short circuit current that would inflow to the point of the fault if there are no changes in network impedances.

Standard IEC 60909 gives calculation methodology of the maximum and minimum short circuit currents. Maximum short circuit currents are used for sizing circuit breakers while minimum short circuit currents are used for setting protective relays. The main factor for calculation of the short circuit currents is pre –fault voltage at the point of the fault and the number of generators in service.

AC current decrement is addressed by considering contribution from every generation source, which depends on the voltage at generator terminals during the short circuit. AC decrement of induction motor is represented in a different way from synchronous machines decrement, because an extra decrement factor that represents the more rapid flux decay is included in induction motors. AC decrement is considered and modelled only when breaking currents are calculated.

DC current decrement that is addressed in IEC 60909, by using the principle of

superposition for the contributing electrical sources in conjunction with topology of the network and the locations of the contributing sources with respect to the location of the fault. Standard IEC 60909 prescribes that different calculation steps need to be used when the contribution converges to a fault location via a meshed or radial path. These conditions are applicable to the calculation of peak and asymmetrical breaking short circuit currents.

Short circuit currents calculated for the steady state take into account fact that the short circuit currents do not contain DC component and that all short circuit current contributions from induction motors have decayed to zero. Synchronous motors also have to be taken into account. Provisions are taken for salient and round rotor synchronous machines and for different excitation system settings.

Loading conditions before the fault are considered with due attention in IEC 60909. In order to account for system loads leading to higher voltages before the fault, the standard advocates that voltages before the fault at the fault location point can be different from 1.00 per unit. This means that load flow solution is not required in order to calculate short circuit currents. IEC 60909 suggests impedance correction factors for the generators. These correction factors can also be applicable to their step up transformers.

### **Differences between the IEEE C37 and IEC 60909**

There are numerous and significant differences between IEEE C37 and IEC 60909 short circuit calculation standards. System modelling and computational techniques are different in the two standards. Because of this results obtained by IEEE and IEC standards can be different, with IEC 60909 generally providing higher short circuit current values. The essential differences between IEEE and IEC short circuit calculation standards can be summarized as follows:

- Short circuit AC current decrement considered by IEC 60909 depends on the fault location and the standard quantifies rotating machinery's proximity to the fault. IEEE standard recommends system-wide modelling of the AC decrement.

- Short circuit DC current decrement described in IEC 60909 does not always rely on a single  $X/R$  ratio. Generally, more than one  $X/R$  ratio has to be taken into account. In addition, the notion of separate  $X$  and  $R$  networks for obtaining the  $X/R$  ratio at the location of the fault is not applicable to IEC 60909.
- Steady-state short circuit current calculation in IEC 60909 considers excitation settings of the synchronous machines.

Considering these important differences, numerical simulations performed using IEEE C37 standards cannot be used to account for the computational requirements of IEC 60909 and vice versa.

### Factors that affect short-circuit studies results

The accuracy of the calculated short circuit currents depends on the modelling accuracy, system configuration and equipment impedances. Other factors include modelling of the electrical machines, generators, grounding point of the system and other system components and different operating conditions.

### Electrical system configuration

Configuration of the electrical system is comprised of the following:

- Location of the potential sources of the fault currents including synchronous generators, synchronous and connection points to utility network
- Network arrangement that defines how fault current sources are interconnected through transmission lines, underground cables, power transformers and bus bars.

Good practice indicates that more than one single line diagram should be consulted for the studied system which depends on the actual operating conditions and the final study objective. If the short circuit current study is done to determine rating of the switchgear, maximum short circuit currents in the system are calculated. This implicates that short



circuit current need to be calculated with all available generators in service with all bus couplers and bus ties closed, while utility interconnectors should be attained to their highest values. If the system study is performed to determine protection relay requirements, some of these conditions do not need to be considered. Various system conditions may require study one or more alternative network arrangements especially for the purpose of determining protective relay settings.

### **Electrical Impedances of the System**

Consideration for the AC and DC current decrement modelling are important factors when it comes to selection of the impedances of the rotating equipment for fault calculations. It is crucial to refer to manufacturer's catalogues and datasheets and if required, to conduct calculations to determine and check reliable impedance values. Standard impedance values can be used in the case no other information is available but these assumptions should be made on the safe side.

Electrical impedances that are assumed should not by any means give lower short circuit current results than those that electrical system can experience in reality. If this is done and the system fault levels are underestimated this can lead to under sizing of the circuit breakers that may not be able to interrupt short circuit currents. Contrary, over estimating anticipated short circuit levels can lead to over sizing required electrical equipment which makes system design impractical and uneconomical and less sensitive protection relay settings. Network utility interconnection must be represented with impedance of the adequate value in order to reflect expected fault level rating. All doubts regarding system impedances should be solved in a way that higher fault levels are obtained for the sake of safety in the design of the overall system. Electrical impedances of bus ducts, busways must be also be considered for low voltage system because they may limit short circuit currents. Also, it is common practice to use saturated impedance values of the synchronous generators.

Finally, resistive components of the system electrical impedances should be modelled considering working temperature especially if considerable lengths of underground cables exist in the system. Although resistances of the system equipment may be

neglected for calculation of the magnitude of the fault currents, they are very critical for calculation of the system X/R ratio at the point of the fault. In general, total system impedance is complex number comprised of its active and reactive part, namely resistance and impedance. It has to be calculated at the point of the fault, to afford correct estimate of the short circuit current. This is especially important for low voltage electrical systems, in which system resistance can be compared in magnitude to the system reactance and it can help to limit the short circuit current.

### **Grounding of the system neutral points**

Faults that include zero sequence data of the electrical equipment such as line to ground faults, double line-to-ground faults, and series faults, the flow of short circuit currents is affected by the grounding conditions of the electrical system. Presence of multiple grounding points is of critical importance as well as the values of electrical system grounding impedances. These grounding impedances can be used, to limit the magnitudes of the line to ground faults to a minimum values, to inhibit over voltages caused by line to ground faults, and to provide reference point for line to ground fault protection. Grounding of the electrical system is also very important for properly simulating zero sequence response of the electrical system. More importantly, for solidly, or low-impedance grounded electrical systems, it is enough to account for only the occasional current limiting transformer and or electrical generator grounding impedances and at the same time ignoring zero sequence impedances of the transmission lines and underground cables. However, this will have to be taken into account for high-impedance grounded, floating, and/or resonant-grounded electrical systems (per IEC 60909).

### **Electrical system loads and shunts before the fault**

It is usual practice to presume that the electrical system is at steady state condition before a short circuit occurs. Introduced simplification that brings in neglecting the load before the fault is based on the fact that the magnitude of the system load current before the fault is, usually, much smaller than the short circuit current. The importance

of the load current before the fault in the system increases along with rated voltage of the system and particular loading patterns of the system. From this reason it is justifiable to assume a 1.00 per-unit voltage before the fault for every bus. This is particularly applicable for typical industrial power system short circuit current calculations. For electrical systems in which loading before the fault is a concern, a load flow analysis should be conducted before short circuit current calculations in order to assure that system voltage profile will be coherent with the existing system loads, shunts, and transformer tap settings. If the actual system condition before the fault is modelled, it is crucial to keep all the system static loads and capacitive line/cable shunts for the short circuit current calculation.

Standard IEC 60909 addresses this issue by using elevated voltages before the fault and impedance correction factors for the synchronous generators. The ANSI and IEEE C37 practice is focused around considering voltage before the fault as being the nominal system voltage with the exception being the assessment of the interrupting requirements of circuit breakers.

### **Zero sequence of mutual coupling**

This phenomenon is very important when parallel circuits share the same corridor and their geometrical arrangement is such that current flow in one circuit causes a voltage drop in the other circuit. Typical example is overhead lines that share the same support structure. It should be pointed out that mutual coupling exists between phases in the positive sequence. This phenomenon of mutual coupling, known as “interphase coupling,” is not explicitly modelled in positive sequence because it is limited within the same circuit of which only one phase is modelled. Coupling of the zero sequence is extended between two or more electrical circuits and needs to be explicitly modelled in zero sequence. Neglecting or incorrectly modelling this phenomenon leads to incorrect ground short circuit current results and wrong performance assessment of distance protection relays. Although this phenomenon is infrequent for industrial power system assessment, it should be properly considered and treated accordingly.

## Delta-wye transformer phase shifts

It is usually assumed that the phase of the short circuit current from primary to the secondary winding remains the same going through transformer when calculating the distribution of the three phase fault in the electrical system. However, this is only true when transformers are Wye-wye and Delta-delta connected. If transformer is Delta-wye connected, phase shift is introduced between primary and secondary winding voltages and currents. Phase shift exists only in positive and negative sequence values. Zero sequence values are not affected by the phase shift. Existing practice in North America indicates that the positive sequence line to ground voltage on the high voltage side of the transformers has to lead the positive sequence line to ground voltage on the transformer low voltage side by 30 degrees. This is also applicable for transformers following IEC standards. If this phase shift is not taken into account for the unbalanced faults, different short circuit current magnitudes are obtained when going through delta-wye transformer since sequence currents are treated as vectors in order to obtain phase short circuit currents. This consequently can lead to misleading relay protection settings which finally can compromise the selectivity and sensitivity of an overcurrent protection scheme.

## Computer solutions

### General

Fault calculations are not that computationally demanding as other power system studies such as load flow or harmonic analyses. Since short circuit current calculations are linear, results for small to medium sized system can be obtained manually, particularly if system electrical resistances are neglected which simplifies overall complex calculation procedure. Short circuit current calculations are further simplified for radial systems. Practical industrial systems can contain several hundred to thousand buses especially if low voltage bus bars are considered and modelled. In those circumstances numerical solutions can be obtained only using computer solutions. It

should be pointed out that speed and reliability of computer based calculations are significantly better even for the small electrical systems.

## Numerical network solutions

Hand short circuit current calculations are based on a series of combinations and transformations of the impedances of the system branches until the electrical system can be represented by an equivalent Thevenin impedance. This process is repeated for every fault location. These hand performed calculations rely on intuition of the system analyst. Computer systems do not have this intuition however they use various techniques. These techniques do not rely on analyst abilities nor do they consider electrical system topology. This is why these techniques are applicable for radial and meshed systems and can accommodate system of almost any size. Notions of admittance and impedance matrices are central in realizing all numerical computer schemes.

## Bus admittance matrix

Bus admittance matrix which is usually referred to as Y-matrix, is a square complex matrix (a matrix that is populated with complex numbers) where number of rows and columns equivalent to the number of system bus bars. Elements of this matrix are component admittances or sums of component admittances. Component admittance represents inverse component complex impedance where component can be branch, generator, generator, motor, etc. When system buses are identified admittance matrix can be formed as follows:

- Allot a diagonal element of a matrix to every bus bar in the system. The value of the diagonal elements in the matrix is the sum of the admittances of all electrical system equipment connected to that bus bar.
- Allot a non-diagonal element to all the matrix elements that represent an

electrical system branch. For example, if an electrical branch is interconnected between buses A and B, the matrix entry  $Y_{AB}$  will be different from zero and equal to the negative sum of the admittances of all electrical components directly interconnected between buses A and B.

Electric systems are passive and they have few branches compared to all of the possible bus connections. As a result, typical electrical power system bus admittance matrices are symmetric. (Keeping in mind assumption that power transformers are not modelled in off-nominal TAP position). That practically means that  $Y_{AB} = Y_{BA}$ , and they are sparse in the case they feature a lot of zero entries.

### The bus impedance matrix

Bus impedance matrix which is usually referred to as Z-matrix is defined as the inverse of the admittance matrix. This matrix is also complex, square and symmetric, in other words the entries  $Z_{ij}$  and  $Z_{ji}$  are equal for passive electrical networks. Since Z-matrix is the inverse of the sparse Y-matrix it is full and does not have zero entries. It can be shown that diagonal elements  $Z_{jj}$  for bus  $j$  are the equivalent Thevenin impedances used for short circuit current calculations. On the other side, entry  $Z_{ij}$ , does not necessarily present value of the physical impedance between buses  $i$  and  $j$ . Actually there will always be an impedance  $Z_{ij}$  although there may not be branch between buses  $i$  and  $j$ . Entries on the diagonal of the Z-matrix are used in calculations of the short circuit currents, whereas entries off the diagonal are useful for calculation of the branch contributions and voltage profiles across the system under fault conditions.

### Short circuit current solution algorithms and system topology

Sparsity of the admittance matrix calls for special computational techniques that are used for storing the data about the system since simple data storage techniques can be insufficient. Storing and keeping entire impedance matrix is not only impractical but also unneeded because only a few of its elements may be necessary. Therefore solution algorithms have focused on effective recovery of the needed impedance matrix entries with the least possible requirements for storage and calculations. Modern computer

software uses calculation and system data storage techniques that focus around so-called “sparse vector” and/or “sparse matrix” calculation techniques which deliver very fast and precise solutions.

### **Computer software**

Commercial software tools are widely used these days although advanced software existed for more powerful hardware platforms and mainframes even in the 1960s. Power system related calculations can now be performed using personal computers and they are recognized as a credible analytical tool due to significant advances in its overall performance, speed, stability and memory as well as user friendly operating system environment. Analytical computer programs were one of the first that were developed for all computer platforms. These numerical programs rely on matrix techniques and ask from system analyst to provide accurate and exact system data so that computer can facilitate analysis and produce required results.

### **Software selection**

There are numerous commercially available computer programs used for short circuit current calculations. They can be differentiated based on a wide variety of the analytical and calculation tasks they perform, sophistication degree of the user-interface and user-friendliness and the computer platform for which they are made. Different computer software tools and different capabilities introduce wide variety in prices therefore it is very important to choose and acquire the software that is suitable for most of the engineering tasks for which it was procured. From the investment point of view it is doubtful, to acquire sophisticated and powerful software tool whose capabilities may be rarely or never used. However, it can be problematic if the user requirements quickly outgrown software capabilities which can compromise the accuracy of the study or end in a consistent waste of time and resources to cover some of the inherited insufficiencies. It is also important to determine to what extent the software is user friendly and computer –literacy of the user who will work with the software. Usually, it is worth working with software that introduces easy data entry, meaningful and helpful error and warning notices, and comprehensive, readable reports. Finally, it is important

to purchase software tool that is properly documented, well supported, and regularly updated and upgraded by its manufacturers.

### Short-circuit current calculation software features

Previously mentioned generally important guidelines for selection of the adequate software tool can be extended by a number of additional features that are particularly applicable and suitable for fault level analyses. One of the most important steps in the short circuit current studies is preparation of the input data. This stage can be also numerically demanding especially if software tool accept inputs only on the per unit basis. It can be considered as very important for computer program to help analyst to prepare data for the study and allow provision for identifying and correcting obvious errors and typos. Whenever international standards are used it is important that software presents calculation method in a transparent way and to provide sufficient information and results that can be easily interpreted.

Table below summarizes some of the very important features of the computer programs that are used for short circuit current studies. These features may or may not be supported by all computer programs. These features are labelled as “Important” and “Optional”. “Very important” mark means that particular feature is frequently encountered in a daily operation and can be considered as indispensable. Category “Important” marks features that will show as very useful for demanding studies while the category “Optional” marks computer software features that may bring additional value for special studies.

Analytical feature	Very important	Important	Optional
Line monitors		Yes	
Currents in all three phases	Yes		
Summary reports		Yes	
Series faults		Yes	
Arcing faults			Yes
Ground faults (LG and LLG)	Yes		
Systems with more than one voltage level	Yes		
Looped and radial system topology	Yes		



Analytical feature	Very important	Important	Optional
Simultaneous faults			Yes
Complex arithmetic	Yes		
Explicit negative sequence			Yes
Interface with power flow		Yes	
Per-unitization of equipment data		Yes	
Currents in all three sequences	Yes		
One-bus-away fault contributions	Yes		
Voltages in nonfaulted buses		Yes	
Input data reports	Yes		
Separate X and R reduction for X/R ratios (IEEE Std C37.010-1979)	Mandatory		
Currents in all branches		Yes	
Interrupting fault currents (IEEE Std C37.010-1979)	Mandatory		
Protection coordination interface		Yes	
Total current multiplying factors (IEEE Std C37.5-1979 factors)	Yes		
X/R—dependent peak multipliers (IEEE Std C37.010-1979)	Yes		
Mutual coupling in zero sequence			Yes
Multiplying factors (IEEE Std C37.13-1990)	Yes		
Transformer phase shifts	Yes		
Methodology in accordance with IEC 60909 (1988)		Yes	
Symmetrical current multiplying factors (IEEE Std C37.010-1979)	Yes		
Rotating equipment impedance adjustment (IEEE Std C37.010-1979)	Yes		
X/R—dependent 1/2 cycle multipliers (IEEE Std C37.010)	Yes		
Remote and local fault contributions (IEEE Std C37.010)	Mandatory		
First cycle fault currents (IEEE Std C37.010-1979)	Mandatory		
Time-delay fault currents (IEEE Std C37.010-1979)		Yes	

## Practical example

In the following sections short circuit current calculations are carried on a typical industrial system. The objective of this example is to demonstrate typical steps,

calculation requirements and way the results are obtained. Studied electrical system is composed of circuits operating on different voltage levels, local generation, and utility interconnection and different rotating loads.

### **Determination of the scope and extent of the study**

It is critical to determine the scope and extent of the short circuit calculations as well as desired accuracy since these factors will influence what types of faults need to be simulated and level of details that need to be considered during system modelling. Number and type of short circuit current studies for a given system is decided based on engineering judgment and common engineering practice. This implies that various network topologies need to be assessed depending on the specific purpose of the study.

Short circuit current calculation results may be used for recommending changes to the existing system or proposing completely new plant design for a system which is in its planning or expansion stage. There are a number of important questions whose answers may be helpful for conducting fault level studies:

1. Is this switchgear sufficient for line to ground faults? If not, should new switchgear be obtained or can some system modifications be effected to avoid the extra capital expenditure?
2. Is non-interrupting equipment such as reactors, underground cables, power transformers, bus ducts, properly rated to withstand short-circuit currents until they are cleared by the interrupting equipment?
3. What will be the effect on the calculated short-circuit currents in the plant electrical system if there is an increase in the utility's fault level?
4. Do the voltages during the fault, on unaffected buses drop to levels that can cause motor-starter contactors to drop out or under voltage relays to operate?
5. Do load circuit breakers or disconnecting switches have adequate momentary bracing and/or close-and-latch capacities?

6. Is electrical circuit breaking equipment sufficient for the system interrupting requirements at all voltage levels?
7. Is particular protective relay equipment necessary to allow protective device selectivity and sensitivity for both maximum and minimum value of fault currents?
8. Can the medium and high voltage switchgear withstand the momentary and interrupting duties enforced by the system?
9. Is there any provision in the interrupting capacity of the circuit breakers and switchgears for accommodating planned system expansion and upgrades? If not, is it essential to have a safety margin for future developments? If so, how can the electrical system be modified to allow these concerns?

Every short circuit current study has to be analysed on different merits and output results should be considered only for the purpose of the conducted study. It is not unusual for these types of short circuit current calculations to consider only three phase short circuit currents since they give more severe fault breaking requirements when compared to other shunt fault types especially when it is known that many of the electrical systems are impedance grounded. Single line to ground faults are necessary to determine adequacy of the switchgears if the electrical system is such that line to ground faults may exceed three phase short circuit currents.

### **Step by step procedures for short circuit current calculation**

The following steps identify the basic considerations in making short circuit current calculations. In the simpler systems, several steps may be combined – for example, use of combined one-line and impedance diagram.

1. Prepare system on-line diagram. Include all significant system components.
2. Decide on short circuit current calculations required, based on type of equipment

being applied. Consider the variation of system operating conditions required to display the most severe duties. Assign bus numbers or suitable identification to the short-circuit locations.

3. Prepare an impedance diagram. For systems above 600 volts, two diagrams are usually required to calculate interrupting and momentary duty for high voltage circuit breakers. Select suitable kVA and voltage buses for the study when the per-unit system is being used.
4. For the designated short circuit locations and system conditions, resolve the impedance network and calculate the required symmetrical currents. When calculations are being made on a computer, submit impedance data in proper form as required by the specific program. For the high voltage equipment, apply appropriate multipliers to calculated symmetrical values so that the short circuit currents will be in terms of equipment rating.

### **A system one-line diagram**

The system one line diagram is fundamental to short circuit analysis. It should include all significant equipment and components and show their interconnections.

### **Type and location of faults required**

All buses should be numbered or otherwise identified. The location where short circuits are required should be selected. In many studies, all buses are faulted. The type of short-circuit currents required is based on the short circuit rating of the equipment located at the faulted bus.

### **System conditions for most severe duty**

It is sometimes difficult to predict which of the intended or possible system conditions should be investigated to reveal the most severe duties for various components. Severe duties are those that are most likely to tax the capabilities of components. Future growth and change in the system can modify short circuit currents. For example, the initial utility

available short circuit duty for system may be 150 mVA but further growth plans may call for an increase in available duty to 750 mVA several years hence. This increase could substantially raise the short circuit duties on the installed equipment. Therefore, the increase must be factored in the present calculations so that adequate equipment can be selected. In a similar manner, future expansions very often will raise short circuit current duties in various parts of the power system so that future expansions must also be considered initially. The most severe duty usually occurs when the maximum concentration of machinery is in operation and all interconnections are closed. The conditions most likely to influence the critical duty include:

1. Which machines and circuits are to be considered in actual operation?
2. Which switching units are to be open or closed?
3. What future expansions or system changes will affect in plant short circuit currents?

### Preparing impedance diagrams

The impedance diagram displays the interconnected circuit impedances that control the magnitude of short circuit currents. The diagram is derived from the system one line diagram, showing impedance for every system component that exerts a significant effect of short circuit current magnitude. Not only must the impedances be interconnected to reproduce actual circuit conditions, but it will be helpful to preserve the same arrangement pattern used in the one line diagram.

### Component impedance values

Component impedance values are expressed in terms of any of the following units:

1. Ohms per phase
2. Percent on rated kVA or a reference kVA base
3. Per unit on a reference kVA

In formulating the impedance diagram, all impedance values must be expressed in the same units, either in Ohms per phase or per unit on a reference kVA base (percent is a

form of per unit).

### Use of per unit of ohms

Short circuit calculations can be made with impedances represented in per unit or ohms. Both representations will yield identical results. Which should be used?

In general, if the system being studied has several different voltages levels or is a high voltage system, per unit impedance representation will provide the easier, more straightforward calculation. Per unit system is ideal for studying multi voltage systems. Also, most of the components included in high voltage networks (machines, transformers and utility systems) are given in per unit or percent values and further conversion is not required. On the other hand, where few or no voltage transformations are involved and for low-voltage systems where many conductors are included in the impedance network, representation of system elements in ohms may provide the easier, more straightforward calculation.

### Neglecting resistance

All system components have impedance ( $Z$ ) consisting of resistance ( $R$ ) and inductive reactance ( $X$ ) where:

$$Z = \sqrt{R^2 + X^2}$$

Many system components such as rotating machines, transformers and reactors have high values of reactance compared to resistance. When the system impedance consists mainly of such components, the magnitude of a short circuit current as derived by the basic equation  $I=E/Z$  is primarily determined by the reactance so the resistance can practically be neglected in the calculation. This allows a much simpler calculation because then  $I=E/X$ .

Conductors (cables, buses and open wire lines) however, have a significant resistance compared to their reactance so that when the system impedance contains considerable conductor impedance, the resistance may have an effect on the magnitude of the short

circuit current and should be included in the calculation.

The result is the appearance of using Z or X interchangeably. The proper concept is that whenever the resistance does not significantly affect the calculated short circuit current a network of reactance alone can be used to represent the system impedance. When the ratio of the reactance to the resistance (X/R ratio) of the system impedance is greater than 4, negligible errors (less than 3%) will result from neglecting resistance. Neglecting R introduces some error but always increases the calculated current. On systems above 600 volts, circuit x/R ratios usually are greater than 4 and resistance can generally be neglected in short circuit current calculations. However, on systems below 600 volts, the circuit X/R ratio at locations remote from the supply transformer can be low and the resistance of circuit conductors should be included in the short circuit current calculations. Because of their high x/R ratio, rotating machines, transformers and reactors are generally represented by reactance only, regardless of the system voltage, an exception being transformers with impedances less than 4%.

### **Per unit representations**

In the per unit system there are four base quantities: base kVA, base volts, base ohms and base amperes. When any two of the four are assigned values, the other two values can be derived. It is common practice to assign study base values to kVA and voltage. Base amperes and base ohms are then derived for each of the voltage levels in the system. The kVA base assigned may be the kVA rating of one of the predominant pieces of system equipment such as a generator or transformer but more conveniently a number such as 10,000 is selected as base kVA. The latter selection has some advantage of commonality when many studies are made while the former choice means that the impedance or reactance of at least one significant component will not have to be converted to a new base.

The nominal line-to-line system voltages are normally used as the base voltages. Conversion of impedances to per unit on an assigned study kVA base will be illustrated for various equipment components. A summary of frequently used per unit relationships follows.

$$\text{Per - unit volts} = \frac{\text{Actual volts}}{\text{Base volts}}$$

$$\text{Per - unit amperes} = \frac{\text{Actual amperes}}{\text{Base amperes}}$$

$$\text{Per - unit ohms} = \frac{\text{Actual ohms}}{\text{Base ohms}}$$

Assigned values for three phase systems

Base volt = line to line volts

Base kVA = three phase kVA

Derived values:

$$\text{Base amperes} = \frac{\text{Base kVA (1000)}}{\sqrt{3}(\text{Base volts})} = \frac{\text{Base kVA}}{\sqrt{3} \text{ Base kV}}$$

$$\text{Base ohms} = \frac{\text{Base volts}}{\sqrt{3} \text{ base amperes}}$$

$$\text{Base ohms} = \frac{\text{Base kV}^2 (1000)}{\text{Base kVA}}$$

Changing from per unit on an old base to per unit on a new base

$$\text{New } X_{pu} = \text{old } X_{pu} \left( \frac{\text{new base kVA}}{\text{old base kVA}} \right)$$

### **The electric utility system**

The electric utility system is usually represented by a single equivalent reactance referred to the user's point of connection which is equivalent to the available short circuit current from the utility. This value is obtained from the utility and may be expressed in several ways.

1. Three phase short circuit kVA available.
2. Three phase short circuit amperes available at a given voltage.
3. Percent or per unit reactance on a specified kVA base.
4. Reactance in ohms-per phase (sometimes R+jX) at a given voltage.



The X/R ratio of a utility source varies greatly. Sources near generating plants have higher X/R ratio (15-30) while short circuit current levels of long open wire line have lower X/R ratios (2-15). Typically, the X/R value of a utility source is from 5 to 12. As explained previously, R may be neglected with small error (less than 3%) when X/R ratio is greater than 4. However, it is always more accurate to include R. If the X/R ratio is known or estimated, then R may be determined by dividing X by the value of X/R ratio.

If X/R=10 and X=0.0025 ohms per phase then  $R = \frac{X}{10} = \frac{0.0025}{10} = 0.00025$  ohms per phase.

Example – Conversion to per unit on a 10,000 kVA base ( $kVA_b$ )

1. Available three phase short circuit kVA 500,000 kVA (500 MVA)

$$X_{pu} = \frac{kVA_b}{kVA_{sc}} = \frac{10,000}{500,000} = 0.02$$

2. Available three phase short circuit amperes = 20,94 at 13.8 kV

$$X_{pu} = \frac{kVA_b}{\sqrt{3} I_{sc} kV} = \frac{10,000}{\sqrt{3} \cdot 20,94 \cdot 13.8} = 0.02$$

3. Equivalent utility reactance=0.2 per unit on a 100,000 kVA base

$$X_{pu} = X_{pu\ old} \left( \frac{kVA_b}{kVA_{old}} \right) = 0.2 \cdot \left( \frac{10,000}{100,000} \right) = 0.02$$

4. Equivalent utility reactance = 0.38 ohms per phase at 13.8 kV

$$X_{pu} = X \left( \frac{kVA_b}{1000 kV^2} \right) = 0.38 \cdot \left( \frac{10,000}{1000 \cdot 13.8^2} \right) = 0.02$$

## Transformers

Transformer reactance (impedance) will almost commonly be expressed as a percent

value (%XT or %ZT) on the transformer rated kVA.

Example – A 500 kVA transformer with an impedance of 5% on its kVA rating (assume impedance is all reactance). Conversion to per unit on a 10,000 kVA base (kVA<sub>b</sub>):

$$X_{pu} = \frac{\%X_T}{100} \left( \frac{kVA_b}{Transf\ kVA} \right) = \frac{5}{100} \cdot \left( \frac{10,000}{500} \right) = 1$$

### Cables and conductors

The resistance and reactance of cable and conductor will most frequently be available in terms of ohms per phase per unit length.

Example – 250 ft. of a three conductor copper 500 mcm cable (600 volt) installed in steel conduit on a 480 volt system. Conversion to per unit on a 10,000 kVA base (kVA<sub>b</sub>):

R=0.0287 ohms/1000 ft.

R=0.00718 ohms/ft.

X=0.0301 ohms/ft.

X=0.00753 ohms/ft.

$$R_{pu} = R \left( \frac{kVA_b}{1000\ kV^2} \right) = 0.00718 \cdot \left( \frac{10,000}{1000 \cdot 0.48^2} \right) = 0.312$$

$$X_{pu} = X \left( \frac{kVA_b}{1000\ kV^2} \right) = 0.00753 \cdot \left( \frac{10,000}{1000 \cdot 0.48^2} \right) = 0.327$$

For high voltage cables (above 600 volts) the resistance of cables can generally be omitted, in fact for short high voltage cable runs (less than 1000 feet) the entire impedance of the cable can be omitted with negligible error.

### Rotating machines

Machine reactances are usually expressed in term of per cent reactance (%X<sub>m</sub>) or per

unit reactance  $X_{pu}$  on the normal rated kVA of the machine. Either the sub-transient reactance ( $X''$ ) or the transient reactance ( $X'$ ) should be selected, depending on the type of short circuit calculation required.

### **Motors rated above 600 volts**

Motors rated above 600 volts are generally high in horsepower rating and will have a significant bearing on short circuit current magnitudes. Very large motors of several thousand horsepower should be considered individually and their reactances should be accurately determined before starting the short circuit study. However, in large plants where there are numerous motors of several hundred horsepower, each located at one bus, it is often desirable to group such motors and represent them as a single equivalent motor with one reactance in the impedance diagram.

### **Motors rated 600 volts or less**

In systems of 600 volts or less, the large motors (of several hundred horsepower) are usually few in number and represent only a small portion of the total connected horsepower. These large motors can be represented individually, or they can be lumped in with the smaller motors, representing the complete group as one equivalent motor in the impedance diagram. Small motors are turned off and on frequently, so it is practically impossible to predict which ones will be on the line when short circuit occurs. Therefore, small motors are generally lumped together and assumed to be running. Where more accurate data are not available, the following procedures may be used in representing the combined reactance of a group of miscellaneous motors:

1. In systems rated 600 or 480 volts, assume that the running motors are grouped at the transformer secondary bus and have a reactance of 25% on a kVA rating equal to 100% of the transformer rating.
2. In all 240 volt systems, a substantial portion of the load consists of lighting, so assume that the running motors are grouped at the transformer secondary bus and have a reactance of 25% on a kVA rating equal to 50% on the transformer rating.

3. Groups of small induction motors as served by a motor control centre can be represented by considering the group to have a reactance of 25% on a kVA rating equal to the connected motor horsepower.

Example – A 500 HP, 0.8 PF, synchronous motor has a sub-transient reactance ( $X_d''$ ) of 15%. Conversion to per unit on a 10,000 kVA base ( $kVA_b$ ):

$$X_d'' = \frac{\%X_d''}{100} \left( \frac{kVA_b}{Motor\ kVA} \right) = \frac{15}{100} \cdot \left( \frac{10,000}{500} \right) = 3$$

### Other circuit impedances

There are other circuit impedances such as those associated with circuit breakers, current transformers, bus structures and connections which for ease of calculation are usually neglected in short circuit current calculations. Accuracy of the calculation is not generally affected because the effects of the impedances are small and omitting them provides conservative short circuit currents. However, on low voltage systems, there are cases where their inclusion in the calculation can result in a lower short circuit current and allow the use of lower rated circuit components. The system designer may want to include these impedances in such cases.

### Shunt connected impedances

In addition to the components already mentioned, every system includes other components or loads that would be represented in a diagram as shunt connected impedances. A technically accurate solution requires that these impedances be included in the equivalent circuit used in calculating a short circuit current, but practical considerations allow the general practice of omitting them. Such impedances are relatively high values and their omission will not significantly affect the calculated results.

### System driving voltage (E)

The system driving voltage (E) in the basic equation can be represented by the use of a

single over-all driving voltage rather than the array of individual, unequal generated voltages acting within individual rotating machines. This single driving voltage is equal to the prefault voltage at the point of fault connection. The equivalent circuit is a valid transformation accomplished by Thevenin's theorem and permits an accurate determination of short circuit current for the assigned values of system impedance. The prefault voltage referred to is ordinarily taken as system nominal voltage at the point of fault as this calculation leads to the full value of short circuit current that may be produced by the probable maximum operating voltage.

In making a short circuit calculation on three phase balanced systems, a single phase representation of a three phase system is utilized so that all impedances are expressed in ohms per phase, and the system driving voltage (E) is expressed in line to neutral volts. Line to neutral voltage is equal to line to line voltage divided by the  $\sqrt{3}$ .

When using the per unit system, if the system per unit impedances are established on voltage bases equal to system nominal voltages, the per-unit driving voltage is equal to 1. In the per unit system, both line to line voltage and line to neutral voltage have equal values. That is, both would have values 1. When system impedance values are expressed in ohms per phase rather than per unit, the system driving voltage would be equal to system line to neutral voltage.

### Short circuit current calculations

After the impedance diagram is prepared, the short circuit currents can be determined. This can be accomplished by longhand calculation, network analyser or digital computer. In general, the presence of closed loops in the impedance network, such as might be found in large industrial plant high voltage system, and the need for short circuit duties at many system locations will favour using digital computer. Simple radial systems, such as those used in most low-voltage systems, can be easily resolved by longhand calculations though digital computers can yield significant time savings particularly when short circuit duties at many locations are required and when resistance is being included in the calculation.

A longhand solution requires the combining of impedances in series and parallel from the source driving voltage and  $Z$  (or  $X$ ) is the single equivalent network impedance. The calculation to derive the symmetrical short circuit current is  $I=E/Z$  where  $E$  is the system driving voltage and (or  $X$ ) is the single equivalent network impedance. When calculations are made in per unit, the following formulas apply:

$$\text{Symmetrical three phase short circuit current in per unit } I_{\text{pu}} = \frac{E_{\text{pu}}}{Z_{\text{pu}}}$$

$$\text{Symmetrical three phase short circuit current in amperes } I = \frac{I_b}{Z_{\text{pu}}}$$

$$\text{Symmetrical three phase short circuit current in kVA } \text{kVA} = \frac{\text{kVA}_b}{Z_{\text{pu}}}$$

where  $I_{\text{pu}}$ - per unit amperes,  $Z_{\text{pu}}$  – equivalent network per unit impedance,  $E_{\text{pu}}$  – per unit volts,  $I_b$ - base amperes,  $\text{kVA}_b$ - base kVA<sub>b</sub>.

A new combination of impedances to determine the single equivalent network impedance is required for each fault location. For a radial system, the longhand solution is very simple. For systems containing loops, simultaneous equations may be necessary though delta-wye network transformations can usually be used to combine impedances.

### Use of estimating tables and curves

There are many times when a short circuit current duty is required at the secondary of a transformer or at the end of a low voltage conductor. Curves and tables, which give the estimated short circuit current duty are available for commonly used transformers and for various conductor configurations. Use of these tables may eliminate the need for a formal short circuit current study and can be used where appropriate.

### Means for reducing short-circuit currents

There is a natural reduction of short circuit current duty due to the impedance of the conductors from the power source to the loads. For example, the short circuit duty at the

terminals of a 1500 kVA, 480 volt transformer may be 37,000 amperes, while at the end of a 600 amp cable run, the duty may be 13,000 amperes. But beyond this natural reduction in short circuit duty, it is sometimes desired or necessary to insert additional impedance in the form of reactance to achieve a lower required duty for application of some specific equipment. This can be done with current limiting reactors (all voltages) or current limiting busways (600 volts and below).

For instance, the available short circuit duty from a utility service supplying a plant or building may be 850 mVA at 13.8 kV. This would require 1000 mVA circuit breakers for the in plant equipment. A more economical approach might be to apply current limiting reactors on the incoming line to reduce the available duty to less than 500 mVA so that lower cost 500 mVA circuit breakers can be applied.

The general procedure is to determine the additional reactance required to reduce the short circuit duty to the desired level as follows:

$$X = \frac{E}{I_{desired}} - \frac{E}{I_{available}}$$

### Example of AC short circuit current calculation

Provided example illustrates how short circuit component are calculated using previously described procedures. It is clear that selection of calculation method must be coordinated with specific component requirements.

Step A – The system one-line diagram

Figure below contains basic details of system components and the way they are connected. Also basic system parameters are shown. The schematic diagram presents the necessary data that is:

- The voltage, short circuit and X/R ratio from the utility system
- The kVA, voltage, connection, impedance and X/R ratio for transformers T1, T2

and T3.

- The type, HP, RPM, reactance and X/R ratios for motors M1, M2, M3 and motor summation designated as M4.
- The length and impedance of the underground cables

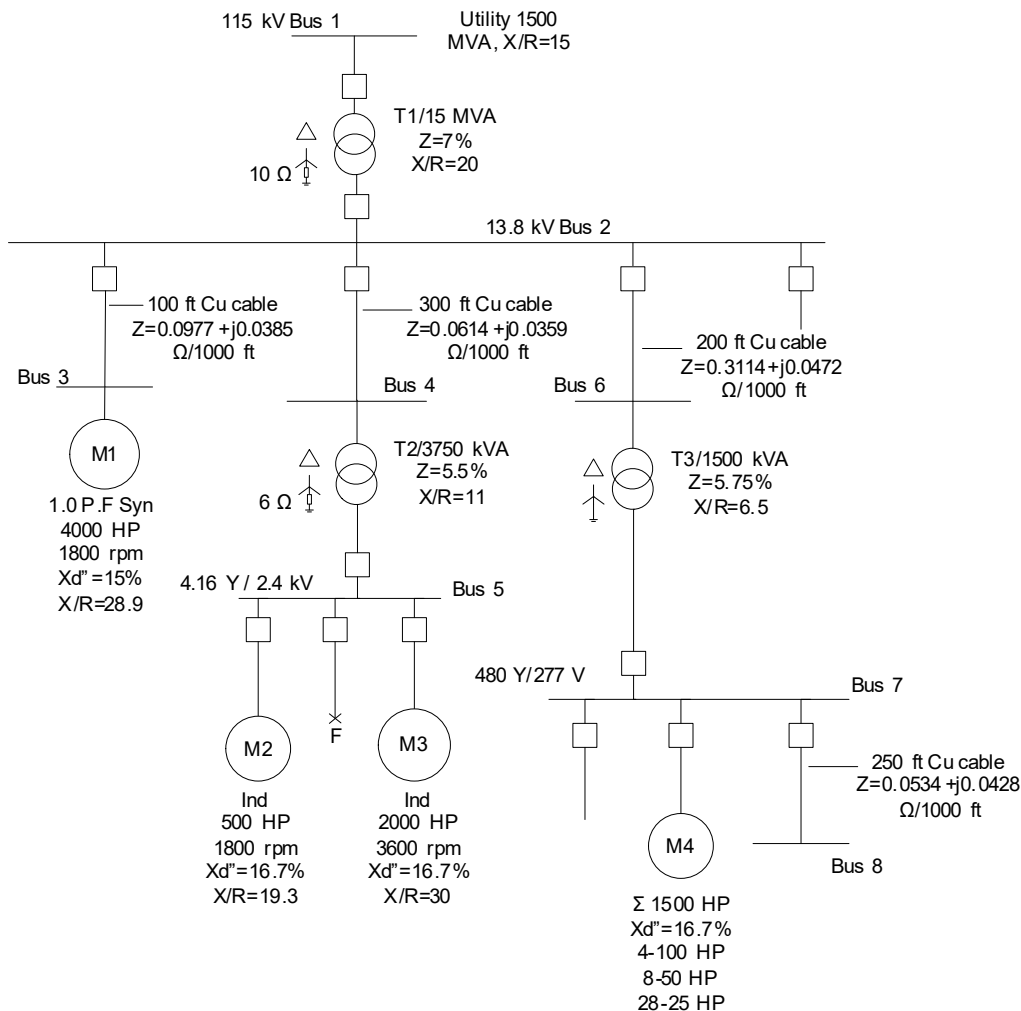

### Step B – Type and location of short circuits

Protective devices are located at buses 2, 5, 7 and 8 and at these locations short circuit currents need to be calculated. High voltage power circuit breakers and associated equipment are located at bus 2 and 5 while low voltage circuit breakers are located at buses 7 and 8. Three phase bolted short circuit are needed for device selection and they will be calculated since line to ground short circuit currents are limited by the



grounding resistors. In addition, the most severe duty occurs when utility is connected, motors are operating and breakers are closed.

### Step C – System impedance diagrams

System impedance diagrams should be presented according to one line diagram. The arrangement of network elements should allow easy identification of given components in the two types of diagrams (one line vs. impedance) although identification of system components and significant points in the network circuit may become difficult or even impossible as the network is resolved and converted into a single value impedance. The per unit system lends itself to an analysis of this system because of the several voltage levels. In this particular example, a base power of 15,000 kVA is selected. The assigned base voltages will be the nominal system voltages of 13,800, 4,160 and 480 volts. Base amperes and base ohms for each of the voltage levels can be derived as shown below:

Assigned Values		Calculated Values	
kVA <sub>B</sub>	kV <sub>B</sub>	I <sub>B</sub>	Z <sub>B</sub>
15,000	13.8	628	12.7
15,000	4.16	2,084	1.1539
15,000	0.48	18,064	0.0153

Figures below are impedance diagrams for the electrical network shown above. The assigned impedance values are based on the ANSI and IEEE recommended machine modified sub-transient  $X_d''$  values for multi voltage systems. The first figure shows first-cycle impedance presentation while the second system impedance diagram presents 1.5 to 4 cycle impedance system.

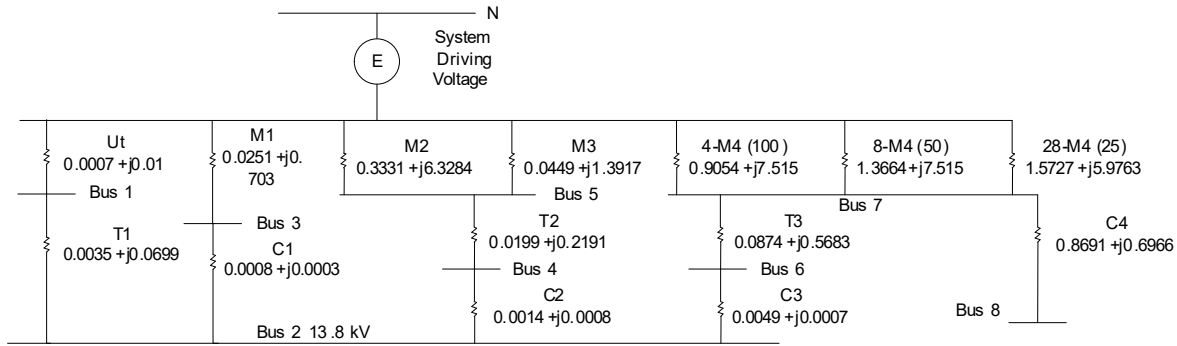

The per unit values for all components impedances for above network impedance diagrams are calculated and shown below:

	<b>First cycle Z=R+jX</b>	<b>1.5-4 cycles Z=R+jX</b>
Utility Z=15,000/1,500,000=0.01 pu		
X/R=15, $\tan^{-1}15=86.19^\circ$ R=(cos 86.19)(0.01), X=(sin 86.19)(0.01)	0.0007+j0.01	0.0007+j0.01
Transformer T1 T1=(7x15,000)/(100x15,000)=0.07 pu X/R=20, $\tan^{-1}20=87.14^\circ$ R=(cos 87.14)(0.07), X=(sin 87.14)(0.07)	0.0035+j0.0699	0.0035+j0.0699
Motor M1 cable Z=0.0977+j0.0386 $\Omega$ /1000 ft Z=(100/1000)x(0.0977+j0.0385)x15/(13.8) <sup>2</sup>	0.0008+j0.0003	0.0008+j0.0003
Motor M1 X=(15x15,000)/(100x4,000x0.8)=0.703 X/R=28, R=X/28=0.0251 1x(R+jX) 1.5(R+jX)	0.0251+j0.703	0.0377+j1.0545

	First cycle $Z=R+jX$	1.5-4 cycles $Z=R+jX$
Transformer T2 cable $Z=0.0614+j0.0359 \Omega/1000 \text{ ft}$ $Z=300/1,000 \times (0.0614+j0.0359) \times 15 / (13.8)^2$	0.0014+j0.0008	0.0014+j0.0008
Transformer T2 $T2=(5.5 \times 15,000) / (100 \times 3750) = 0.22 \text{ pu}$ $X/R=11, \tan^{-1} 11 = 84.80^\circ$ $R=(\cos 84.8)(0.22), X=(\sin 84.8)(0.22)$	0.0199+j0.2191	0.0199+j0.2191
Motor M2 $X=(16.7 \times 15,000) / (100 \times 500 \times 0.95) = 5.2737$ $X/R=19, R=X/19=0.2776$ 1.2x(R+jX) 3.0(R+jX)	0.3331+j6.3284	0.8328+j15.8211
Motor M3 $X=(16.7 \times 15,000) / (100 \times 2000 \times 0.9) = 1.3917$ $X/R=31, R=X/31=0.0449$ 1.0x(R+jX) 1.5(R+jX)	0.0449+j1.3917	0.0674+j2.0875
Transformer T3 cable $Z=0.3114+j0.0472 \Omega/1000 \text{ ft}$ $Z=200/1,000 \times (0.3114+j0.0472) \times 15 / (13.8)^2$	0.0049+j0.0007	0.0049+j0.0007
Transformer T3 $T2=(5.75 \times 15,000) / (100 \times 1500) = 0.575 \text{ pu}$ $X/R=6.5, \tan^{-1} 6.5 = 81.25^\circ$ $R=(\cos 81.25)(0.575), X=(\sin 81.25)(0.575)$	0.0874+j0.5683	0.0874+j0.5683
Motor M4 $\Sigma 1500 \text{ HP}$ Assumed 25% 100 HP = 4-100 HP 35% 50 HP = 8-50 HP Remainder 25 HP = 28 – 25 HP 100 HP $X = (16.7 \times 15,000) / (100 \times 4 \times 100) = 6.2625$ $X/R=8.3, R=X/8.3=0.75457$ 1.2 (R+jX) 3.0 (R+jX)	0.9054+j7.515	2.2635+j18.7875
50 HP $X = (16.7 \times 15,000) / (100 \times 8 \times 50) = 6.2625$ $X/R=5.5, R=X/5.5=1.1386$ 1.2 (R+jX) 3.0 (R+jX)	1.3664+j7.515	3.4158+j18.7875
25 HP $X = (16.7 \times 15,000) / (100 \times 28 \times 25) = 3.5786$ $X/R=3.8, R=X/3.8=0.9417$ 1.67 (R+jX)	1.5727+j5.9763	

	First cycle $Z=R+jX$	1.5-4 cycles $Z=R+jX$
Cable (Bus 7 to Bus 8) $Z=0.0534+j0.0428 \Omega/1000 \text{ ft}$ $Z=250/1,000 \times (0.0534+j0.0428) \times 15 / (0.48)^2$	0.8691+j0.6966	

#### Step D – Calculation of short circuit current

Presented results depend on the method used to resolve the impedance network. Accurate results will be obtained if network resolution is treated as a complex quantity. If the network is treated as a separate R and X networks the result will provide slightly higher short circuit currents. In the case the system impedance has a large resistance compared to the reactive component then the resultant current calculation will increase. Completely separate R and X calculation is performed to calculate the short circuit X/R ratios in line with ANSI standard. The base voltages were assigned values and they are equal to the nominal system voltages. These voltages are same as pre-short circuit or operating voltages. Basically, the system per-unit driving voltage (E) equals 1.

Two cases are presented by:

- Pointing out an applicable network
- Pointing out network resolution
- Solving the network to a single value impedance
- Calculating symmetrical fault current

#### Case One – The First Cycle Short Circuit Current Calculation at location F

The impedances shown in the system impedance diagrams can be resolved into single impedance value that limits the value of the three phase short circuit current at fault location F. The resolution methods that are applied are:

Method A: Neglecting resistive components of the impedances except for low voltage

cables and resistive and reactive component for high voltage cables. This can be justified since neglected components have smaller values than considered components.

Method B: Consider both resistive and reactive components however resolve each independently. This can be done to consider all resistances and reactance but to simplify calculation compared to calculation Method C.

Method C: Consider all components resistive and reactive and solve the network as a complex quantity.

Method A – Network resolution

Branch	X	1/X
Ut+T1	0.01+0.07	12.5
M1	0.703	1.4225
$\Sigma M4+T3$	2.3068+0.575	0.347
(Ut+T1)+ M1+( $\Sigma M4+T3$ )	0.0701	14.2695
(Ut+T1+ M1+M4+T3)+T2	0.0701+0.22	3.4473
M2	6.3284	0.158
M3	1.3917	0.7185
Net X	0.2313	4.3238
Equivalent $Z=0+j0.2313$ per unit		

Method B – Network resolution

Branch	R	1/R
Ut+T1	0.0007+0.0035	238.0952
M1+C1	0.0251+0.0008	38.61
$\Sigma M4+T3+C3$	0.4045+0.0874+0.0049	2.0129
(Ut+T1)+ (M1+C1)+( $\Sigma M4+T3+C3$ )	0.0036	278.7181
(Ut+T1+ M1+C1+ $\Sigma M4+T3+C3$ )+C2+T2)	0.0036+0.0014+0.0199	40.1626
M2	0.3331	3.0021
M3	0.0449	22.2717
Net R	0.0153	65.4364

Branch	X	1/X
Ut+T1	0.01+0.0699	12.5156
M1+C1	0.703+0.0003	1.4219
$\Sigma M4+T3+C3$	2.3068+0.5683+0.0007	0.3477
(Ut+T1)+ (M1+C1)+( $\Sigma M4+T3+C3$ )	0.07	14.2852
(Ut+T1+ M1+C1+ $\Sigma M4+T3+C3$ )+C2+T2)	0.07+0.0008+0.2191	3.4495

Branch	X	1/X
M2	6.3284	0.158
M3	1.3917	0.7185
Net X	0.2312	4.326
Equivalent Z=Net R + Net X=0.0153+j0.2312 per unit		
X/R ratio = 0.2312/0.0153=15.11		

### Method C – Network Resolution

$$U_t+T_1+M_1+C_1=0.0036+j0.0718$$

$$M_4+T_3+C_3=0.5392+j2.8839$$

$$M_2+M_3=0.041+j1.1409$$

$$(U_t+T_1+M_1+C_1)+(\Sigma M_4+T_3+C_3)=(0.0036+j0.0718)\times(0.5392+j2.8839)/$$

$$((0.0036+j0.0718)+(0.5392+j2.8839))=0.0037+j0.0701$$

$$(U_t+T_1+M_1+C_1+\Sigma M_4+T_3+C_3)+C_2+T_2=(0.0037+0.0014+0.0199)+j(0.0701+0.0008+0.2191)=0.025+j0.29$$

Net Z =

$$(U_t+T_1+M_1+C_1+\Sigma M_4+T_3+C_3+C_2+T_2)+(M_2+M_3)=(0.025+j0.29)\times(0.041+j1.1409)/$$

$$((0.025+j0.29)+(0.041+j1.1409))=0.0175+j0.2313 \text{ per unit}$$

The symmetrical short circuit current at location F is:

$$I = I_b(I \text{ per unit}) = I_b \cdot \frac{E}{Z_{net}} = 2084 \cdot \frac{1}{Z_{net}} = \frac{2084}{Z_{net}}$$

Method	Z net (per unit)	Symmetrical RMS (A)
A	0+j0.2313	9010
B	0.0153+j0.2312	8994
C	0.0175+j0.2313	8984

It can be concluded that calculated currents differ only by 0.3% depending on the calculation method which justifies neglecting high voltage resistance as well as cable reactance thus simplifying calculations.

### Case Two – 1.5-4 Cycle Short Circuit Current Calculation

#### Method A – Network resolution

Branch	X	1/X
--------	---	-----

Ut+T1	0.01+0.07	12.5
M1	1.05+5	0.9483
M4 (4-100 HP)	18.7875	0.0532
M4 (8-50 HP)	18.7875	0.0532
ΣM4	9.3985	0.1064
ΣM4+T3	9.3985+0.575	0.1003
(Ut+T1)+ M1+( ΣM4+T3)	0.0738	13.5486
(Ut+T1+ M1+M4+T3)+T2	0.0738+0.22	3.4037
M2	15.8211	0.0632
M3	2.0875	0.479
Net X	0.2534	3.9459
Equivalent Z=0+j0.2534 per unit		

Method B – Network resolution

Branch	R	1/R
Ut+T1	0.0007+0.0035	238.0952
M1+C1	0.0377+0.0008	25.974
M4 (4-100 HP)	2.2635	0.4418
M4 (8-50 HP)	3.4158	0.2928
ΣM4	1.3614	0.7346
ΣM4+T3+C3	1.3614+0.0874+0.0049	0.6879
(Ut+T1)+ (M1+C1)+( ΣM4+T3+C3)	0.0038	264.7571
(Ut+T1+ M1+C1+ΣM4+T3+C3)+C2+T2)	0.0038+0.0199+0.0014	39.8406
M2	0.8328	1.2008
M3	0.0674	14.8368
Net R	0.0179	55.8782

Branch	X	1/X
Ut+T1	0.01+0.0699	12.5156
M1+C1	0.703+0.0003	0.948
M4 (4-100 HP)	18.7875	0.0532
M4 (8-50 HP)	18.7875	0.0532
ΣM4	9.3985	0.1064
ΣM4+T3+C3	9.385+0.5683+0.0007	0.1003
(Ut+T1)+ (M1+C1)+( ΣM4+T3+C3)	0.0737	13.5639
(Ut+T1+ M1+C1+ΣM4+T3+C3)+C2+T2)	0.0737+0.2191+0.0008	3.4057
M2	15.8211	0.0632
M3	2.0875	0.479
Net X	0.2533	3.9479
Equivalent Z=Net R + Net X=0.0179+j0.2533 per unit		
X/R ratio = 0.2533/0.0179=14.2		

### Method C – Network Resolution

$$U_t+T_1=M_1+C_1+\Sigma M_4+T_3+C_3=0.0038+j0.0738$$

$$M_2+M_3=0.0639+j1.8442$$

$$(U_t+T_1+M_1+C_1+\Sigma M_4+T_3+C_3)+C_2+T_2=(0.0038+0.0199+0.0014)+j(0.0738+0.2191+0.0008)=0.0251+j0.2937$$

$$(U_t+T_1+M_1+C_1)+(\Sigma M_4+T_3+C_3)=(0.0036+j0.0718) \times (0.5392+j2.8839) / ((0.0036+j0.0718)+(0.5392+j2.8839)) = 0.0037+j0.0701$$

$$Z=(U_t+T_1+M_1+C_1+\Sigma M_4+T_3+C_3+C_2+T_2)+(M_2+M_3)=(0.0251+j0.2937) \times (0.0639+j1.8442) / ((0.0251+j0.2937)+(0.0639+j1.8442))=0.0199+j0.2534 \text{ per unit}$$

The symmetrical short circuit current 1.5 to 4 cycle after fault at location F is:

$$I = I_b(I \text{ per unit}) = I_b \cdot \frac{E}{Z_{net}} = 2084 \cdot \frac{1}{Z_{net}} = \frac{2084}{Z_{net}}$$

Method	Z net (per unit)	Symmetrical RMS (A)
A	0+j0.2534	8224
B	0.0179+j0.2533	8207
C	0.0199+j0.2534	8199

### Summary

This course presented fundamental facts about calculating short circuit currents in the electrical power systems. Fault types are described and how these fault types are treated by various international standards. Important considerations about network equipment that need to be taken into account when calculating fault levels were mentioned. Basic conversion to per units was described for various electrical network elements. Two different calculation methods were demonstrated on the practical electrical system along with step by step calculation procedure.