



HVDC Technology - Part 2

Course Number: EE-05-933

PDH: 5

Approved for: AK, AL, AR, FL, GA, IA, IL, IN, KS, KY, LA, MD, ME, MI, MN, MO, MS, MT, NC, ND, NE, NH, NJ, NM, NV, NY, OH, OK, OR, PA, SC, SD, TN, TX, UT, VA, VT, WI, WV, and WY

New Jersey Professional Competency Approval #24GP00025600

North Carolina Approved Sponsor #S-0695

Maryland Approved Provider of Continuing Professional Competency

Indiana Continuing Education Provider #CE21800088

Florida Provider #0009553 License #868

NYSED Sponsor #274

This document is the course text. You may review this material at your leisure before or after you purchase the course. In order to obtain credit for this course, complete the following steps:

1) Log in to My Account and purchase the course. If you don't have an account, go to New User to create an account.

2) After the course has been purchased, review the technical material and then complete the quiz at your convenience.

3) A Certificate of Completion is available once you pass the exam (70% or greater). If a passing grade is not obtained, you may take the quiz as many times as necessary until a passing grade is obtained (up to one year from the purchase date).

If you have any questions or technical difficulties, please call (508) 298-4787 or email us at admin@PDH-Pro.com.

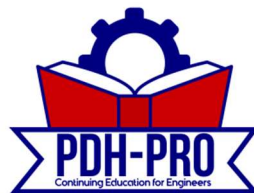

HVDC TECHNOLOGY – COMPLETE COURSE – PART 2

HARMONICS EFFECTS IN AC POWER SYSTEMS

Harmonics within a power system are expressed as the voltage or current modulation at an integer multiple of the fundamental frequency. Therefore on a 50 Hz system, the presence of 5th harmonic voltage means that there is an extra 250 Hz component superimposed on the voltage waveform. This component will distort the voltage waveform. Voltage waveform is presented in Figure 1. The presence of harmonics in the power system can cause some unwanted effects on installed power system devices.

The presence of harmonics can cause:

- Capacitor banks overheating
- Power electronic devices instability
- Generator overheating
- Communication systems interference

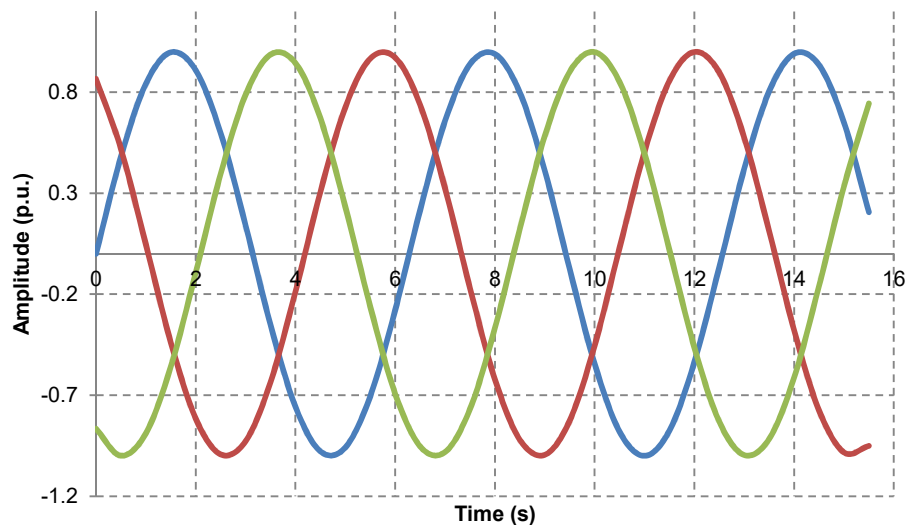

Figure 1. Three-phase fundamental frequency sine wave

AC POWER SYSTEMS HARMONICS SOURCES

All devices that contain a non-linear element and are connected to a power system can generate harmonics. This is a consequence of either their design or their operation. Examples of harmonics sources within a power system are:

- Domestic electronics (video, personal computers, television, etc.)
- Power converters (HVDC, SVC, drives)

Non-linear devices

- Voltage limiters
- Transformers
- Fluorescent lights
- PWM converters
- Rotating Machines

Typical network harmonic profile is presented in Figure 2.

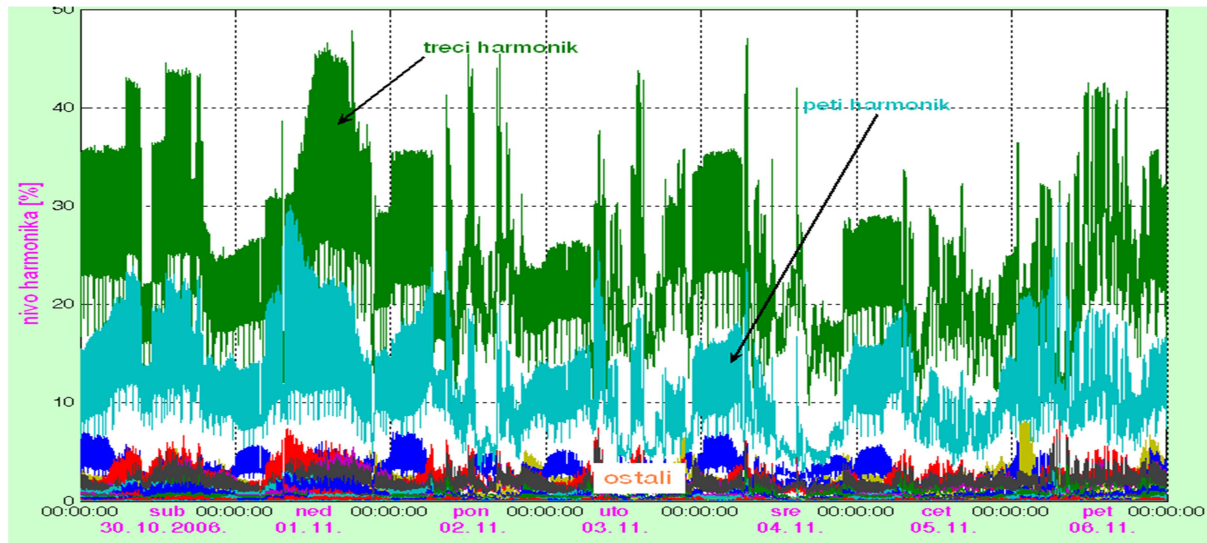

Figure 2. Harmonic profile in a typical power system

HOW CONVERTERS GENERATE HARMONICS

The AC/DC converter is a source of harmonics. This is because the converter connects the supply to the load for a controlled period of a fundamental frequency cycle. Therefore, the current taken from the supply is not sinusoidal. Looked from the AC side, a converter can be conceived as a current harmonics generator. This is shown in Figure 3. If looked from DC side, it can be conceived as voltage harmonics generator, as presented in Figure 4. The actual harmonics level produced by an AC/DC converter is a function of the duration over which a particular phase is needed to provide unidirectional current to the load. Therefore, the higher the converter “pulse number” (which means the more switching between phases within a cycle) the lower the harmonic distortion in both the AC line current and the DC terminal voltage.

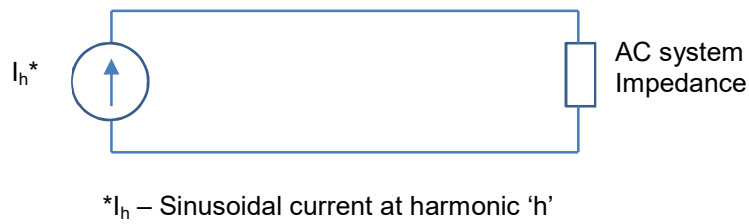

Figure 3. AC/DC converter shown as AC harmonic current source on AC side

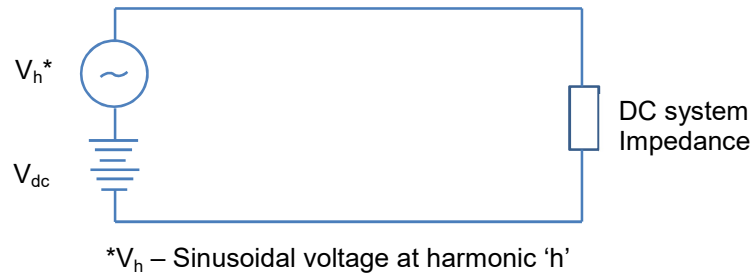

Figure 4. AC/DC converter shown as AC harmonic voltage source on DC side

PULSE NUMBER AND HARMONIC CANCELLATION

The main elements of a common HVDC converter terminal are presented in Figure 5.

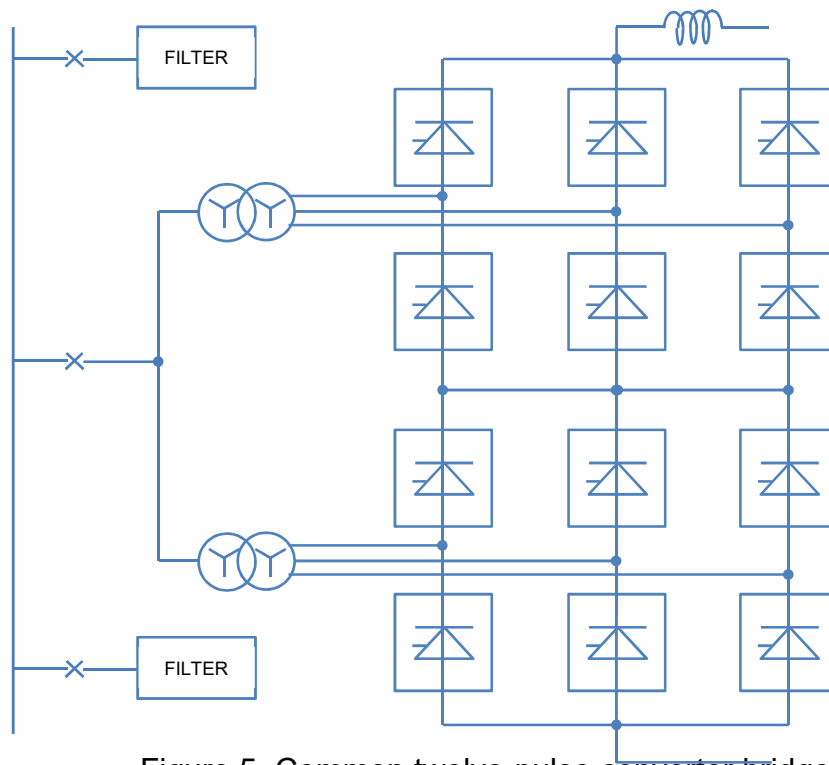

Figure 5. Common twelve-pulse converter bridge

The action of the thyristor sequential switching results in current waveforms in the transformer line side which consists of current “blocks” is presented in Figure 6.

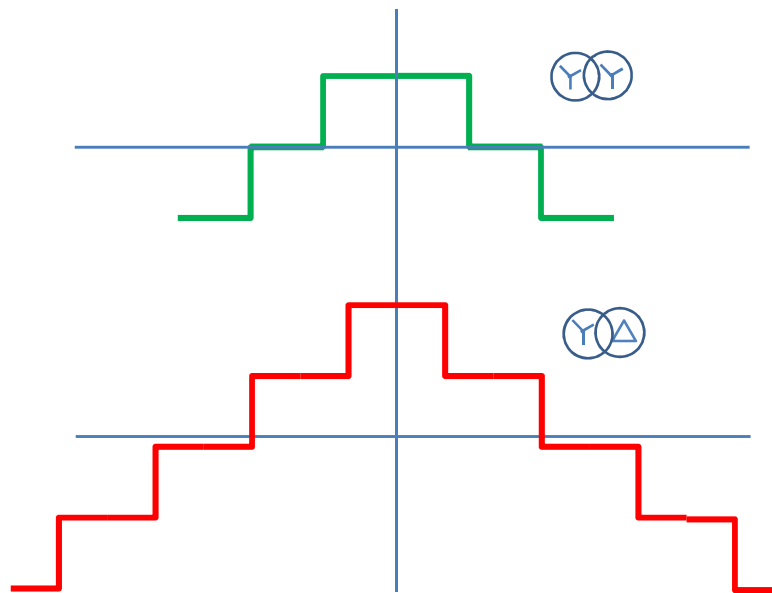

Figure 6. Idealized line winding currents in a twelve-pulse bridge

If a Fourier analysis is completed on the idealized waveforms presented in Figure 6, the next results are found:

$$I = \frac{2\sqrt{3}}{\pi} \times I_d \times \left[\cos \omega t - \frac{1}{5} \cos 5\omega t + \frac{1}{7} \cos 7\omega t - \frac{1}{11} \cos 11\omega t + \frac{1}{13} \cos 13\omega t \dots \right] \dots Y/Y \quad (1)$$

$$I = \frac{2\sqrt{3}}{\pi} \times I_d \times \left[\cos \omega t + \frac{1}{5} \cos 5\omega t - \frac{1}{7} \cos 7\omega t - \frac{1}{11} \cos 11\omega t + \frac{1}{13} \cos 13\omega t \dots \right] \dots Y/\Delta \quad (2)$$

It can be noted from equations (1) and (2) that each six-pulse bridge produces harmonic orders $6n \pm 1$, $n = 1, 2, 3 \dots$. There are no triplen harmonics (3rd, 6th, 9th...) and that for $n = 1, 3, \text{etc.}$, the harmonics are phase shifted by 180° . The idealized magnitudes of the six-pulse harmonics are presented in Table 1. By combining two six-pulse bridges with a 30° phase shift between them, i.e. by using Y/Y and Y/Δ transformers as presented in Figure 5 and summing equations (1) and (2), a twelve-pulse bridge is found. The idealized magnitudes of the twelve-pulse harmonics are presented in Table 2.

Table 1. Idealized harmonic magnitudes in a six-pulse bridge

Fundamental	50 Hz	1
5 th	250 Hz	0.2
7 th	350 Hz	0.14
11 th	550 Hz	0.09
13 th	650 Hz	0.08
17 th	850 Hz	0.06
19 th	950 Hz	0.05
23 rd	1150 Hz	0.04
25 th	1250 Hz	0.04
n	n x 50 Hz	1/n

Table 2. Idealized harmonic magnitudes in a twelve-pulse bridge

Fundamental	50 Hz	1
5 th	250 Hz	-
7 th	350 Hz	-
11 th	550 Hz	0.09
13 th	650 Hz	0.08
17 th	850 Hz	-
19 th	950 Hz	-
23 rd	1150 Hz	0.04
25 th	1250 Hz	0.04
n	n x 50 Hz	1/n

The current waveforms presented in Figure 7 appear in the typical connection to the transformers presented in Figure 5.

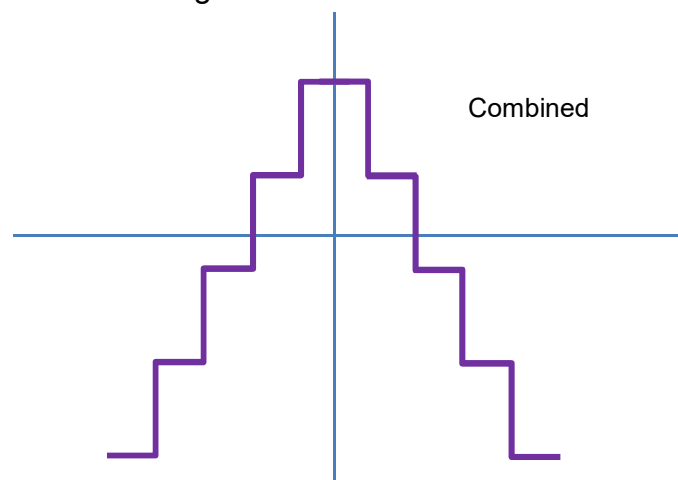

Figure 7. Idealized waveform of the AC supply current of a twelve-pulse bridge

If a Fourier analysis is completed on this idealized waveform, the following result is found:

$$I = \frac{4 \times \sqrt{3}}{\pi} \times I_d \times \left[\cos \omega t - \frac{1}{11} \cos 11\omega t + \frac{1}{13} \cos 13\omega t - \frac{1}{23} \cos 23\omega t + \frac{1}{25} \cos 25\omega t \dots \right] \dots (3)$$

Therefore, in a twelve-pulse bridge, the harmonic orders $6n \pm 1$, $n = 1, 3, 5 \dots$ are effectively cancelled in the common supply leaving the characteristic twelve-pulse harmonics i.e. $12n \pm 1$, $n = 1, 2, 3, \dots$

The idealized waveforms presented above will be changed by the system supply reactance (predominantly the transformer reactance). Due to this commutating reactance, the harmonic current magnitudes are decreased in comparison to those relevant to pure square wave pulses. The formulas presented above are based on the assumptions that the DC current is linear, the DC reactor is infinite and the AC system voltage waveforms are sinusoidal. Because these assumptions are not applicable for real systems, more complex computations are necessary and purpose built computer programs are applied. For special needs (e.g. net harmonic contribution from two or more bridges of slightly different firing angles or reactances) both magnitude and phase (i.e. vector solutions) are needed.

DC HARMONICS

The idealized voltage across an unloaded six-pulse converter is presented in Figure 8, and the idealized voltage across a twelve-pulse converter is presented in Figure 9. The voltage is a mix of a direct voltage and harmonics. Table 3 presents the DC side harmonics generated by a six-pulse converter.

Table 3. Idealized DC voltage harmonics (RMS) at the six-pulse bridge terminals

No-load (V_{d0})	DC	1.0000
6 th	300 Hz	0.0404
12 th	600 Hz	0.0099
18 th	900 Hz	0.0044
24 th	1200 Hz	0.0025

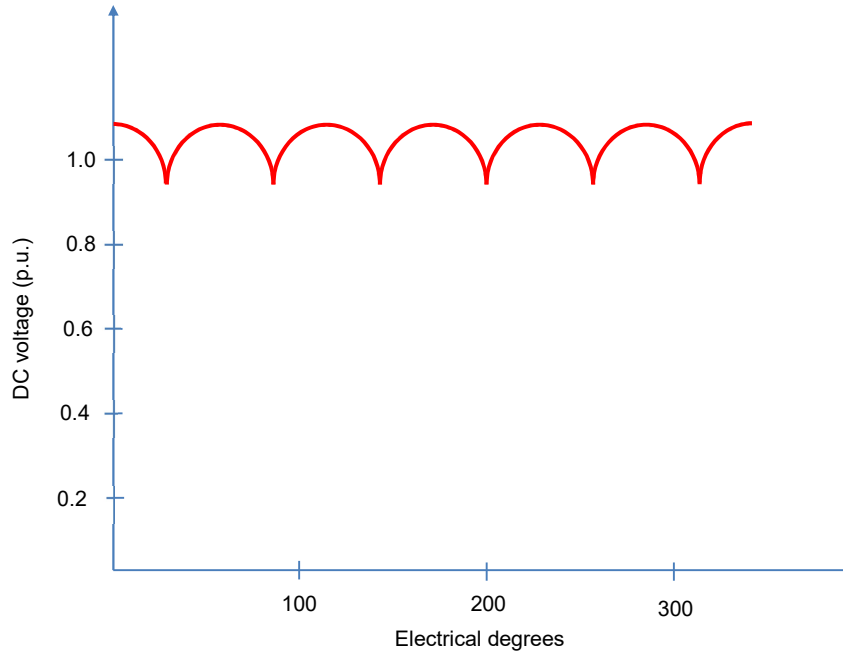

Figure 8. The idealized voltage across unloaded six-pulse bridge DC terminals

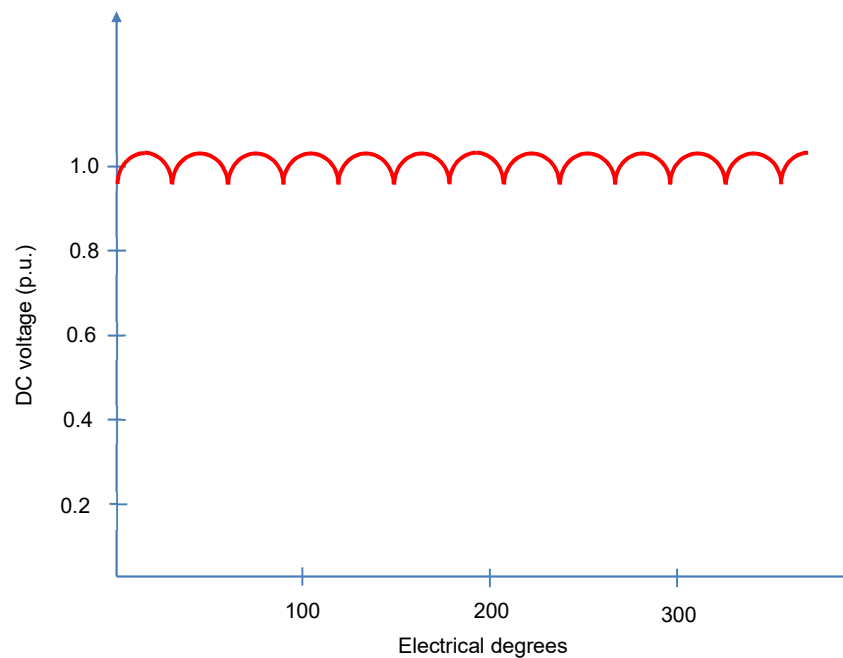

Figure 9. The idealized voltage across the unloaded twelve-pulse bridge DC terminals

CHARACTERISTIC AND NON-CHARACTERISTIC HARMONICS

The harmonic currents derived from the examination of the ideal converter are known as the converter “characteristic harmonics”. Nevertheless, a real converter can cause

generation of other harmonic currents which result from non-ideal working conditions. These harmonics are known as “non-characteristic harmonics”. Non-characteristic harmonics can be caused by several sources. An unbalance or “negative phase sequence” in the AC supply system will result in the 2nd harmonic generation on the converter DC side. A harmonic not anticipated by the $6n$ or $12n$ analysis previously described will increase 3rd harmonic current which is injected back into the AC system by the converter. Unbalance between the converter transformer leakage reactances for the Y and Δ bridges will end in a small amount of each of the classical harmonics. They should have been totally cancelled but are still present in the AC side current. Stray capacitance which is inherent in the converter transformer valve winding bushings will give a stray path within the converter for harmonic currents to flow leading to the generation of triplen harmonics (3rd, 9th and 15th) on the DC side and ± 1 of these harmonic numbers on the AC side. Moreover, insignificant control inaccuracies within the converter controller resulting in the firing instance between bridge valves not being ideally symmetrical (the error is much less than 0.1° electrical) will generate harmonics at all multiples of n on converter AC and DC side.

CROSS-MODULATION HARMONICS

In addition to the characteristic and non-characteristic harmonics which can be created by a converter, there is a third type of harmonic known as cross-modulation harmonics. These harmonics are based on the fact that in any HVDC link the DC current is never absolutely smooth. This is especially correct in the case of a back-to-back converter in which case there is little or no impedance between the two converters. In most situations, it is not practical to put sufficient inductance between the converters to make a substantial impact on the interaction between them. In most situations, the AC connection of one converter is remote, or even isolated from that of the other converter. Hence, even where the two AC systems interconnected by the DC link are typically at the same AC frequency (50 Hz or 60 Hz) the real working frequencies may be different. Therefore, AC side currents harmonic and DC side voltages created by the converters, which are a multiple of the used AC system frequency, will be at different frequencies. In the case where the two AC interconnected systems work at different AC frequencies, for example one at 50 Hz and one at 60 Hz, then the difference in the harmonics created by the converters will be higher. The actual DC converter sides are connected together and therefore the harmonic voltage distortion introduced by one converter will be applied to the DC terminals of the other converter and vice versa. These harmonic voltage distortions will create a distortion in the circulating DC current which will cause harmonics to be made in each converter that are a multiple of the other converter's AC system frequency and not of its own. For instance, the 60 Hz converter will have AC current harmonics matching 11th and 13th harmonic at 660 Hz and 780 Hz respectively and a corresponding DC side harmonic at 720 Hz. Nevertheless, this 720 Hz distortion

will result in 660 Hz and 780 Hz components in the AC current harmonics of the 50 Hz connected converter. None of these frequencies are an integer multiple of 50 Hz and non-integer harmonics are generated.

HARMONIC FILTER DESIGN AND FILTER TYPES

The HVDC converter AC side current waveform, as previously discussed, is highly non-sinusoidal, and, if allowed to run in the connected AC network, might generate unacceptable distortion levels. Hence, AC side filters are needed as part of the complete HVDC converter station in order to decrease the harmonic distortion of the AC side current and voltage to acceptably low levels. HVDC converters also use substantial reactive power, a high proportion of which must typically be locally provided within the converter station. Shunt-installed AC filters act as capacitive sources of reactive power at fundamental frequency. Typically in common HVDC configurations the AC filters are used to compensate most or all of the converter reactive consumption. Extra shunt capacitors, reactors, Static VAR Compensators (SVCs), Static Compensators (STATCOMs) or synchronous compensators may also be installed to ensure that the required reactive balance is kept within specified limits under defined working conditions. Therefore, the design of the AC filters typically has to meet these two harmonic filtering requirements and reactive power compensation, for different operational states and load levels.

FILTER CIRCUIT ARRANGEMENTS

There are different possible circuit arrangements that can be suitable for AC side filters on HVDC converter stations. This paragraph reviews these arrangements to provide background information on the benefits and disadvantages of particular filter types. Only shunt-installed filters are taken into consideration in this section. The comments on special filter designs apply to HV- and EHV connected filters and same to MV-connected filters, e.g. tertiary installed filters.

The selection of the proper filter solution is the contractor responsibility and will vary from project to project. The configuration will be impacted by a number of factors that may be determined by the customer:

- Converter control strategy (reactive power control, voltage and overvoltage control),
- AC system conditions (supply voltage variation, negative phase sequence voltage, frequency variation, system harmonic impedance),

- Defined harmonic limits (voltage distortion, current injection, telephone interference factors),
- Switched filter size (determined by voltage step limit, self-excitation limit of nearby synchronous machines, reactive power balance etc.),
- Environmental effects (ambient temperature range),
- Loss evaluation criteria,
- Site area (limited switch bays),
- Availability and reliability requirements.

Various filter arrangements will have certain benefits and disadvantages when considering the above factors. Since, only the filter design and performance aspects are looked at, additional devices such as surge arresters, current transformers and voltage transformers are omitted. In HV and EHV applications, surge arresters are normally installed within the filters to grade the insulation levels of the equipment.

BENEFITS AND DISADVANTAGES OF COMMON FILTERS

Two main filter types are applied today:

- The tuned filter or band-pass filter. It is sharply tuned to one or several harmonic frequencies. These filters are tuned to a specific frequency, or frequencies. They are known by a relatively high q (quality) factor, i.e. they have low damping. The resistance of the filter may be connected in series with the capacitor and inductor (more often it is simply the loss of the inductor), or in parallel with the inductor, in which case the resistor has a high value. Examples of tuned filters include single (e.g. 11th) double (e.g. 11/13th) and triple (e.g. 3/11/13th) tuned filter types.
- The damped filter or high-pass filter providing a low impedance over a broad band of frequencies. These are filters made to damp more than one harmonic. For example, a filter tuned at 24th harmonic will provide low impedance for both 23rd and 25th harmonic, and even for most of the higher harmonics. Damped filters always include a resistor in parallel with the inductor which generates a damped characteristic at frequencies above the tuning frequency. Damped filter examples include single-tuned damped high-pass (e.g. HP12) and double-frequency damped high-pass (e.g. HP 12/24). The differentiation between these two filter types may sometimes be lost depending on the selection of q -value for

different filter frequencies. For a HVDC configuration with a twelve-pulse converter, the highest characteristic harmonics will be the following: 11th, 13th, 23rd, 25th, 35th, 37th, 47th, and 49th. As the level of the 11th and 13th harmonic are typically twice as high as for the rest of the harmonics, a typical practice is to install band-pass filters for the 11th and 13th harmonic and high-pass filters for the higher harmonics. Due consideration also has to be taken concerning the potential low-order resonance between the AC network and the filters and shunt banks. When a big HVDC configuration is to be installed in a weak AC system, a low-order harmonic filter (typically tuned to 3rd harmonic) may be also required.

BAND-PASS FILTER

A band-pass filter comprises LC series resonance circuit as presented in Figure 10. Figure 11 presents the impedance magnitude and phase of a band-pass filter. The benefits and the disadvantages of a single-tuned band-pass filter are as follows:

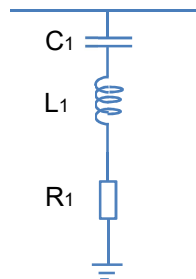

Figure 10. Single-tuned band-pass filter arrangement

Benefits:

- Simple connection with only two elements,
- Insignificant losses,
- Optimal damping for one harmonic,
- Low maintenance needs.

Disadvantages:

- Multiple filter branches may be required for various harmonics,
- May need possibility of adjusting reactors or capacitors,
- Sensitive to detuning effects.

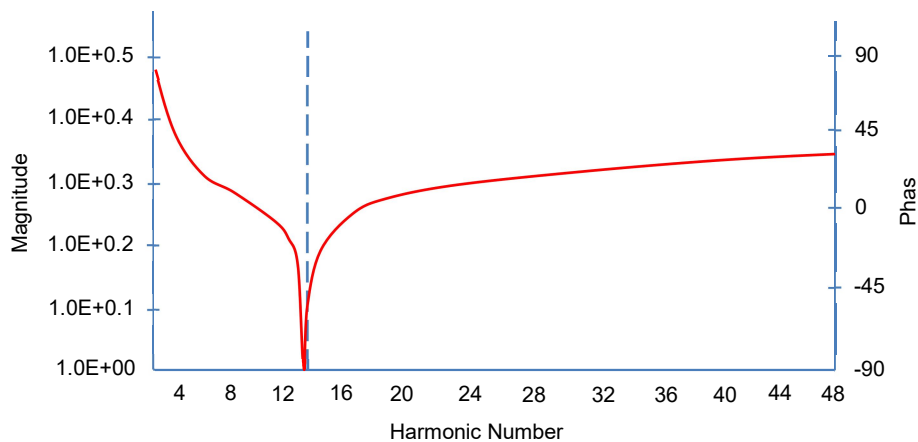

Figure 11. Single-tuned band-pass filter – impedance characteristic

DOUBLE-TUNED BAND-PASS FILTER

A double-tuned band-pass filter has the same function of two single-tuned filters. Its arrangement is presented in Figure 12, and its impedance plot in Figure 13. The benefits and the disadvantages of a double-tuned band-pass filter are as follows:

Benefits:

- Optimal damping for two harmonics,
- Only one HV capacitor and reactor required to filter two harmonics,
- Lower loss than for two single tuned branches,
- Fewer branch types, facilitating filter redundancy,
- Mitigates minimum filter size problem for a low magnitude harmonic.

Disadvantages:

- Sensitive to detuning effects,
- Complex connection, with 4 or 5 C-L-R elements,
- May need option of adjusting reactors or capacitors,
- Needs two arresters to control insulation levels.

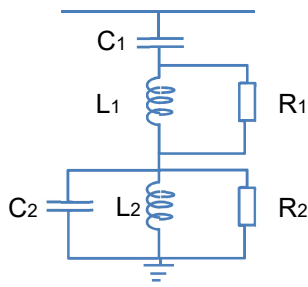

Figure 12. Double-tuned band-pass filter arrangement

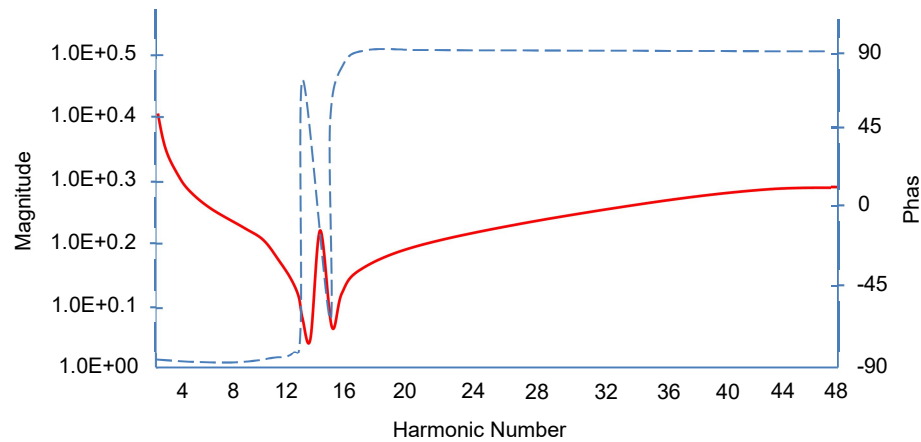

Figure 13. Double-tuned band-pass filter – impedance characteristic

TRIPLE-TUNED BAND-PASS FILTER

This filter type is electrically same to three parallel-connected tuned filters, but is implemented as a single combined filter. Figure 14 presents the circuit configuration and Figure 15 the impedance/frequency response for a common triple-tuned filter. The application of triple-tuned filters could enhance the operational requirements for reactive power control. This would be of particular interest at low-load conditions if a 3rd harmonic filter is required in the circuit from the beginning. For each of the above configurations, sensitivity to detuning has been distinguished as a disadvantage. Nevertheless, with the installation of resistors (and therefore additional losses) to make the filter configuration damped, this detuning can be avoided.

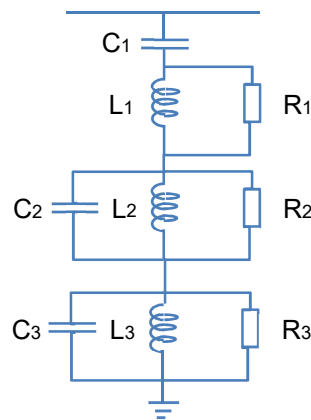

Figure 14. Triple-tuned band-pass filter configuration

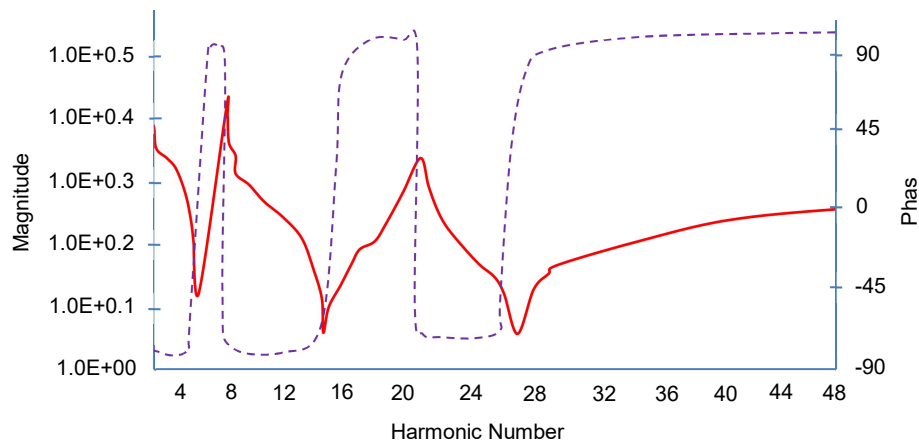

Figure 15. Triple-tuned band pass filter tuned to 3rd, 11th and 24th harmonic – impedance characteristic

AC HARMONIC PERFORMANCE AND RATING COMPUTATIONS

The basis of harmonic distortion and filter performance computations can be presented with reference to Figure 16.

- I_n - converter harmonic current
- I_{sn} - harmonic currents entering the supply system
- I_{fn} - filter harmonic currents
- Z_{sn} - AC system harmonic impedance
- Z_{fn} - Filter harmonic impedance

The current and voltage distortion can be determined from the following equations:

$$I_{sn} = \frac{Z_{fn}}{Z_{fn} + Z_{sn}} \times I_n \quad (4)$$

$$V_n = \frac{Z_{fn} \times Z_{sn}}{Z_{fn} + Z_{sn}} \times I_n \quad (5)$$

In order to compute harmonic performance and design the filters (i.e. Z_{fn}), it is mandatory that comprehensive data is available on the harmonic currents produced by the HVDC converter (I_n) and the supply system harmonic impedance (Z_{sn}).

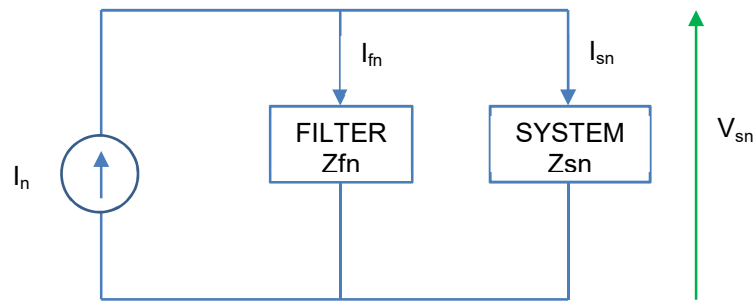

Figure 16. Circuit for AC filter performance assessment

SUPPLY SYSTEM HARMONIC IMPEDANCE

In order to precisely evaluate voltage and current distortion, it is vital that the supply system impedance is known at each harmonic of interest. Nevertheless, a lack of knowledge of the system harmonic impedance could lead to an uneconomic filter configuration, or a filter that will not adequately attenuate harmonics. There are few modeling methods of the system impedance:

IMPEDANCE CIRCLE METHOD

In a supply system with substantial shunt capacitance, the system impedance can be either inductive ($R + jX_L$) or capacitive ($R - jX_C$) at the Point of Common Coupling (PCC) at harmonic frequencies. Therefore, resonances will happen when the inductive (X_L) and capacitive ($-X_C$) components are same and only the resistance component (R) remains. Figure 17 presents a common impedance locus of a supply system as the frequency varies from 50 Hz to about 255 Hz.

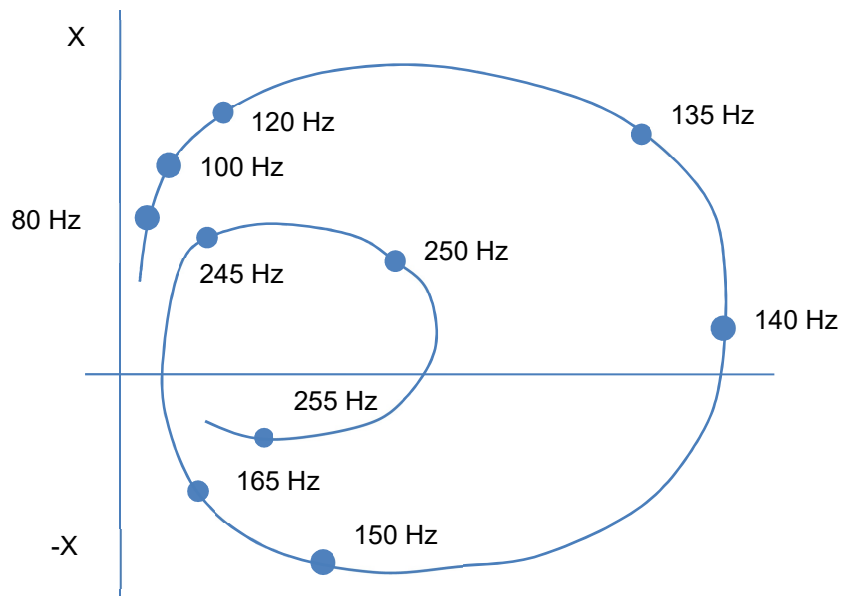

Figure 17. Common supply network impedance diagram

In this case, the system seems inductive at 100 Hz, but capacitive at 150 Hz with a resonance around 140 Hz. Additional resonances happen below 245 Hz and above 250 Hz. The system impedance can quickly vary for small frequency changes. The above locus applies to only one system arrangement, with different generation, load or line outage conditions, further impedance loci would happen. In order to make sure that the system harmonic impedance (Z_{sn}) used in filter design computations is applicable to all present and future system arrangements, a circle is typically drawn which encloses all of the computed loci. An example of such a circle is presented in Figure 18. When conducting filter design studies, the system impedance is taken to be any value within the circle which ends in the highest harmonic distortion (i.e. V_{sn} or I_{sn}). Computer maximization procedures are applied to search for the impedance area at each harmonic. In order to reflect the system impedance reality, limitations to the search area are typically specified. Limit lines of angles Φ_1 , Φ_2 (commonly $75^\circ - 85^\circ$) are applied, and minimum values of R may be defined. This process is safe as it inherently caters to system changes and future needs. Nevertheless, it is also pessimistic as each harmonic, especially at low orders, which will only change within a limited range, and not within a large circle. The application of this approach may end in an over-designed and expensive filter.

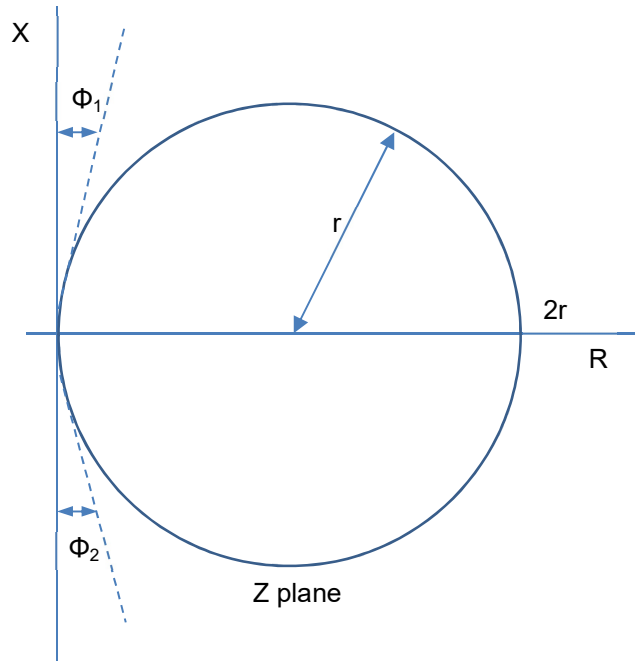

Figure 18. AC network impedance

POLYGON METHOD

At each harmonic, the system will have an impedance discrete value corresponding to various arrangements. Hence, at each harmonic the system impedance can be determined by a polygon which covers all of the computed discrete harmonics. Such a polygon is presented in Figure 19. The computer maximization process searches each defined polygon at each harmonic to compute the highest harmonic distortion (V_{sn} or I_{sn}). This method provides a realistic evaluation of the system impedances, and avoids any problems of filter overdesign.

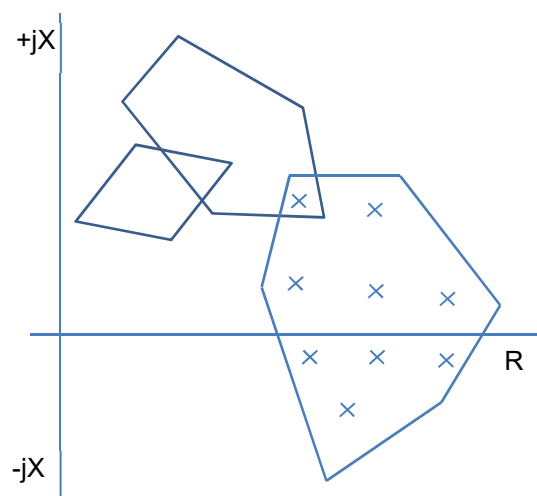

Figure 19. Impedance polygon

DC HARMONIC PERFORMANCE AND RATING COMPUTATIONS

The DC side harmonic performance of a HVDC configuration is somehow easier to compute than that of the AC side. Comparison of Figure 16 to Figure 20 indicates that the basic circuit assessment is similar. Nevertheless, unlike the AC system, which can exist in many different states (that is, different arrangements of transmission lines, loads, generation, etc.) the DC system is a determined system with several possible variations in configuration.

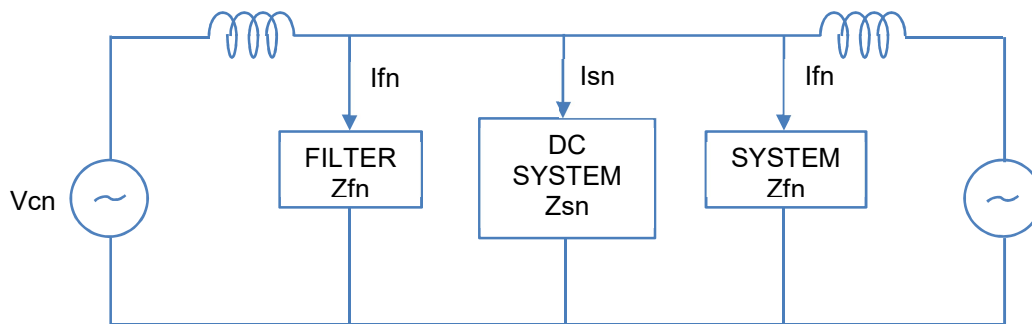

Figure 20. Circuit assessment for DC filter performance

Figure 21 presents a sample frequency versus impedance plot for an overhead transmission line. The normal performance evaluation method of an overhead DC transmission line is based on induced current, that is, the current that would run in a conductor parallel to the DC line.

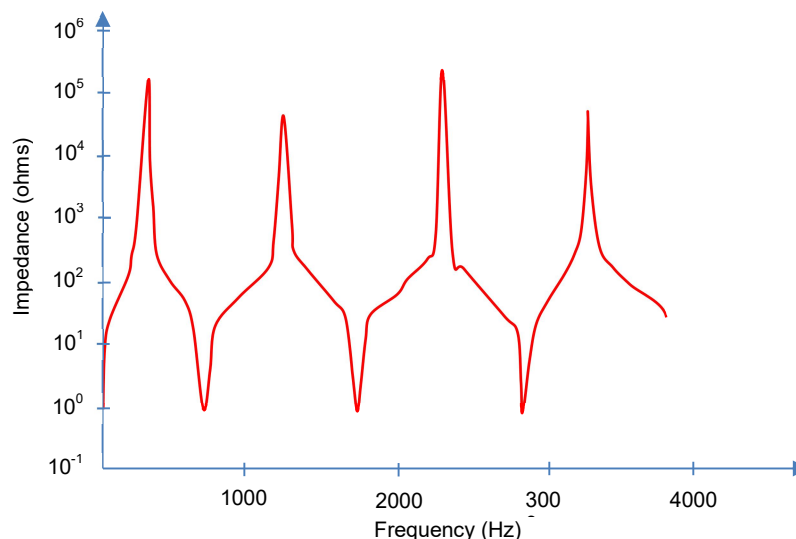

Figure 21. Common HVDC line impedance characteristic

The higher the ground impedance, the greater the induced currents in a parallel line, as this parallel line will present a viable current return path. Conversely, in locations where

the ground impedance is low, the current induced in a parallel line will be insignificant. Hence, the arrangement and rating of the DC side filter is influenced by the ground conditions related with the DC line. When working in balanced bipolar mode, the harmonic currents will run through the DC lines in such a way that at any point along the line, the instantaneous harmonic currents in one pole's DC conductor will be same and opposite to that in the other. Hence, the currents induced in a parallel conductor will be decreased. Therefore, the worst-case DC harmonic operation and the case which defines the DC filter rating, is monopole operation.

Crucial consideration in the DC filter design, as opposed to an AC filter, is the main capacitor bank as, on the DC side, this will be subject to the used DC voltage. Therefore, the sharing of the DC voltage as well as the AC voltage must be controlled. This means that the resistive voltage distribution has to be controlled in DC capacitors (Figure 22). For this reason it is typical for DC filter capacitor banks to be made as one single tall bank as opposed to any form of split bank where the split banks would have post insulators between the capacitor racks and disturb the voltage distribution due to leakage currents across them.

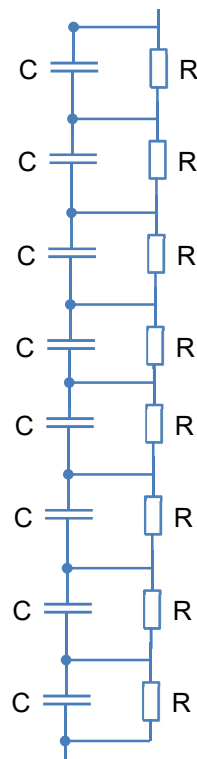

Figure 22. DC filter capacitor

CONTROL FACILITIES GIVEN BY HVDC CONFIGURATIONS

The fundamental control parameter of a HVDC converter is the DC current which flows between the rectifier and inverter assuming that the DC voltage is kept at a constant value (which is commonly true for DC power transmission configurations but not always correct for back-to-back arrangements). Nevertheless, the HVDC controller can adjust the DC current flow in response to other parameters that are set by operator providing an extremely flexible and quick part of a power system's transmission infrastructure. Common control options provided or available as an extra feature are presented below.

POWER CONTROL

The power transmitted between the sending and receiving end of the HVDC link is controlled to meet an operator-set value at the point in the circuit where the DC power is defined, known as the compounding point. Commonly the compounding point is at the rectifier DC terminal but it can also be at the inverter DC terminal, the mid-point of the DC transmission conductors, the inverter AC terminal or the rectifier AC terminal. If the power requirement is varied then the power order will ramp to the new power transfer level at a rate of change (known as the "ramp rate") pre-determined by the operator. Commonly, the maximum power limit is determined by an overload controller which is continuously computing the thermal capacity of the converter station devices.

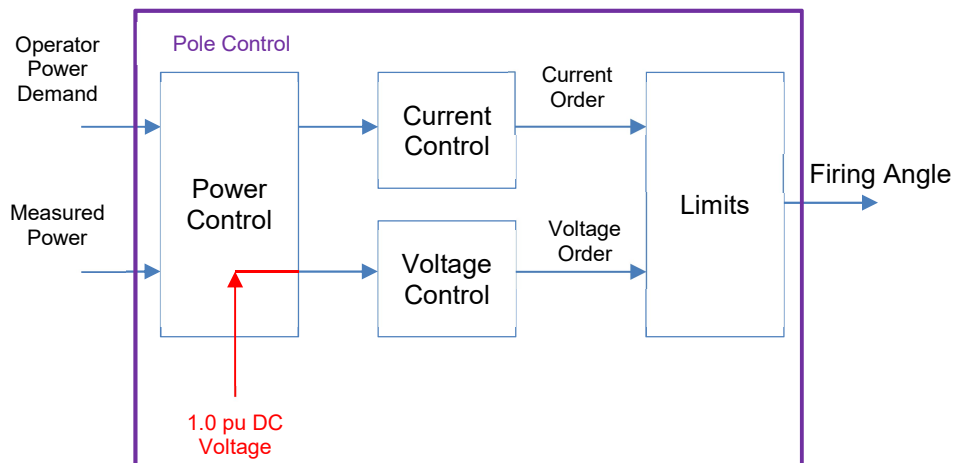

Figure 23. HVDC configuration power control

HVDC CONFIGURATION FREQUENCY CONTROL

A HVDC configuration can control the AC system frequency by automatically correcting the power being delivered into that AC system in order to balance the load with the

supply. The quick HVDC power control decreases the under-frequency or over-frequency which can result from a varying load in a small power system such as an island load. Frequency control can also be used as limits to the power control function. For instance, the sending end can be arranged so that it will continue to provide power via the HVDC link to the receiving end as so long as the sending end AC system frequency is above some predetermined value. In this way the sending end can be protected from a serious system disturbance as a consequence of a disturbance in the receiving end AC system. The controllability of a HVDC configuration is crucial and is sometimes referred to as providing a “firewall”. With a power system consisting of “islands” of AC interconnected with DC, this HVDC “firewall” property will reduce the risk of cascading black-outs across multiple interconnected AC systems. Other frequency limits can be set, for example the receiving end AC system could have an upper frequency limit to automatically stop additional increases in the power being delivered by the HVDC configuration. Equally, the receiving AC system can have a lower frequency limit which, if reached, automatically increases the power being delivered into the receiving AC system. However, this can typically be overridden by the sending end minimum frequency limit described above, that is, the sending end system will help out the receiving end AC system as much as possible without risking a cascade failure.

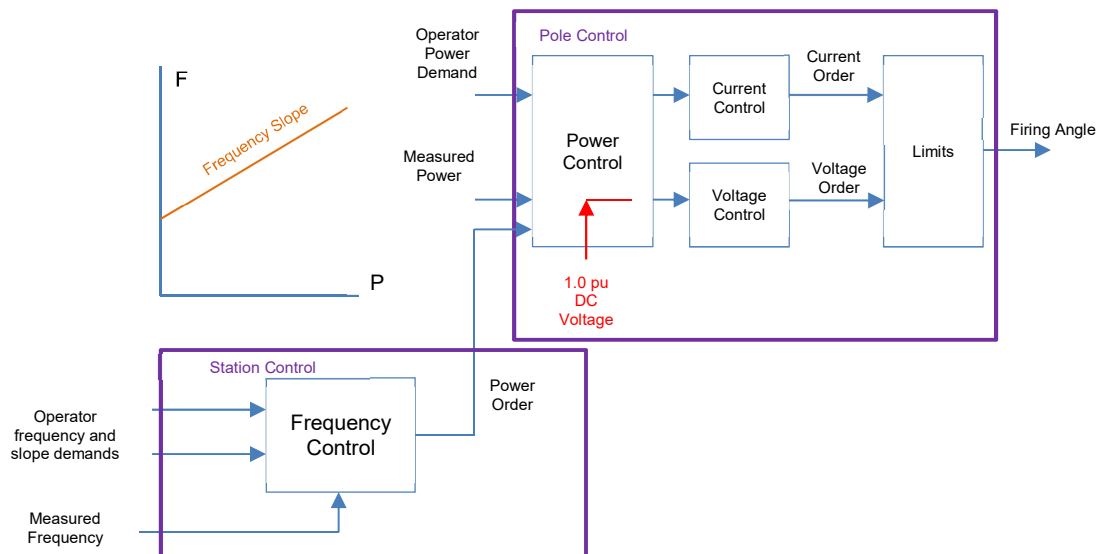

Figure 24. HVDC configuration frequency control

HVDC CONFIGURATION POWER MODULATION CONTROL

The power being transmitted through a HVDC link can be automatically modulated to give damping to low-frequency power oscillations within either, or both, interconnected AC systems. This is decided by system studies during the project design phase.

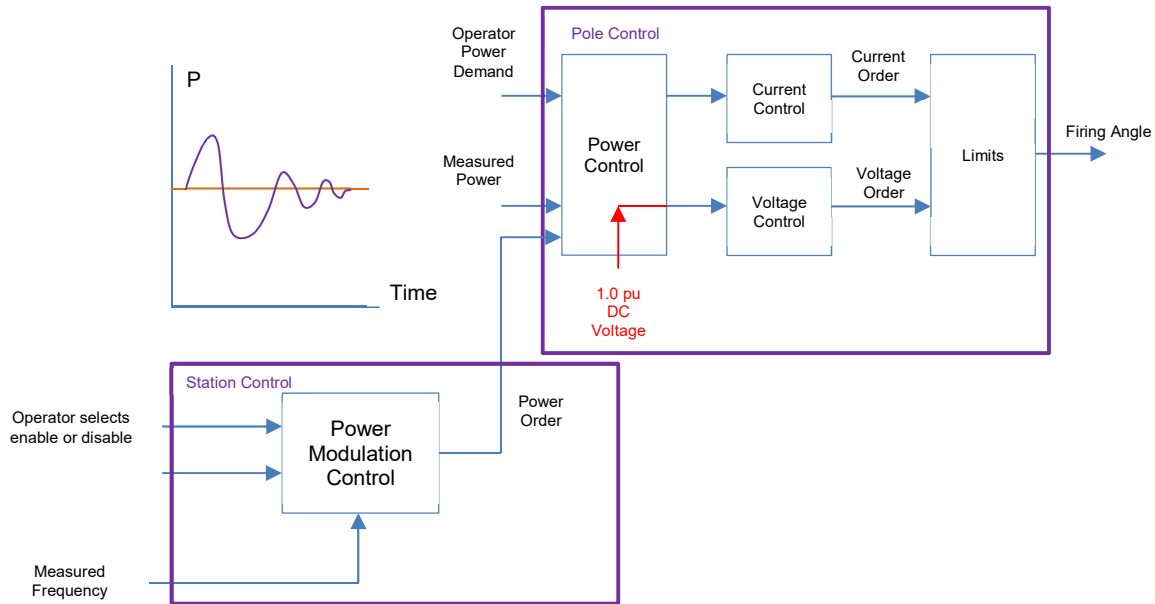

Figure 25. Typical HVDC configuration power modulation control

RUNBACK/POWER DEMAND OVERRIDE (PDO)

In response to certain situations, such as outage of an AC line, outage of an AC generator or outage of a big load, the HVDC interconnection can be made to respond in a pre-defined sequence. For example, if the line outage may end in instability within the AC system, the HVDC interconnection can be set to decrease the power transfer at a pre-defined ramp rate to a safe value as suggested by contract studies. In the same way, the generator outage can be pre-programmed to automatically increase the power transfer through the HVDC interconnection.

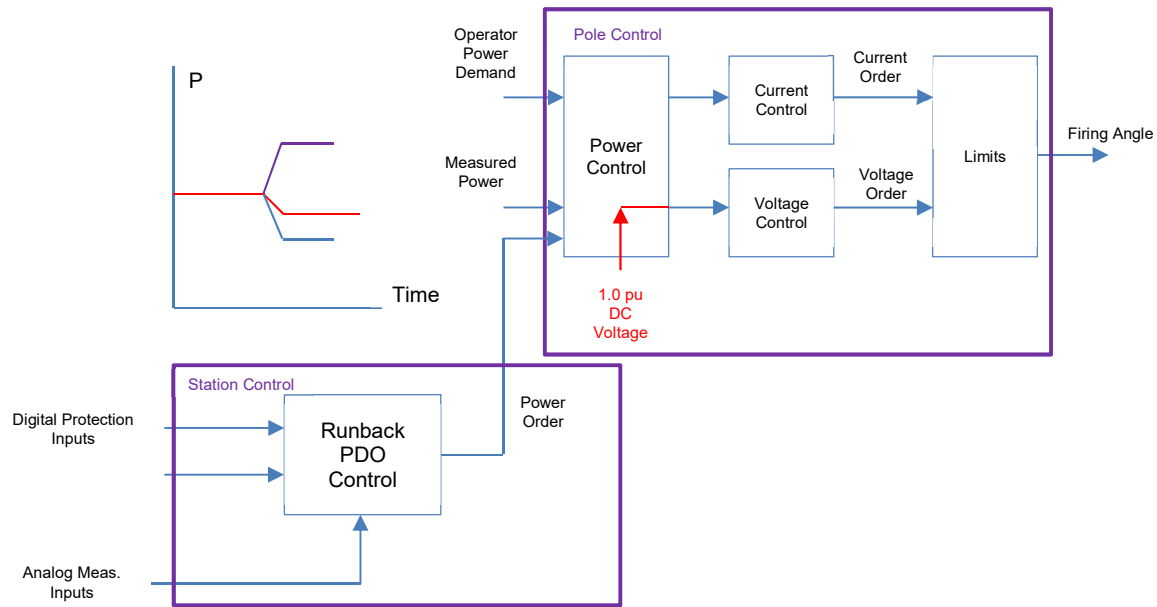

Figure 26. Runback/power demand override (PDO)

DC PROTECTION

A detailed description of the protections applied to HVDC station is beyond this course. Nevertheless, it is worth pointing that within a HVDC converter station the protection types used fall into two groups:

- Conventional (AC) substation protection
- DC protection

AC connected devices such as converter transformers and AC harmonic filter elements, along with feeders and busbars, are protected using typical AC protection relays. The converter, along with the DC circuit, is protected using hardware and software that is specifically designed. Common DC protections include:

- AC > DC
- DC Differential
- AC Overcurrent
- DC > AC
- DC Overcurrent
- AC Overvoltage
- AC Undervoltage
- Asymmetry

- Abnormal firing angle
- DC Undervoltage
- Low DC current

HVDC THYRISTOR VALVES

The term “valve” originates from the HVDC early days, when mercury-arc valves were used for this function. Mercury-arc valves worked in a completely different way (being basically vacuum tubes, therefore the name “valve”) but fundamentally completed the same job as a modern thyristor valve. When thyristors were brought in, the name “valve” was kept. The thyristor valve is the fundamental element of the modern HVDC converter. The real thyristor valve contains many series-connected thyristors in order to give the necessary blocking voltage capability. Thyristors used for HVDC valves are amongst the largest semiconductors of any type. These elements are expensive and there may be many thousand such components in a HVDC station. Also, they are rather delicate and need many additional elements to control and protect them. Even though it is the most evident component of a thyristor valve, the thyristors account for a surprisingly low percentage of the overall valve cost.

Modern thyristor valves are rather typical. The majority of the design work is completed during the product development phase. Therefore, applying the valves to a particular project is a relatively straightforward process. At its simplest, the work needed for a particular project may just involve adjusting the number of series-connected thyristors according to the voltage rating demands imposed by the overall system design. HVDC valves are almost never used as separate units. Almost always, few valves are combined together into a “Multiple Valve Unit”, or MVU. The MVU may either be directly installed on the floor or suspended from the ceiling. For insulation economy, the valve design is usually arranged so that the lower-voltage valves (typically those related with the delta connected six-pulse bridge) are used as part of the insulation on which the higher-voltage valves (typically those related with the star-connected bridge) are installed. Therefore, the low voltage end is the end at which the valve is attached to the floor or ceiling. The valves are commonly piled vertically into “quadrivalve” structures. Three quadrivalves are needed at each end of each pole.

Figure 27 presents a typical suspended MVU. Special attention has been paid to possible fire initiation processes within the modern thyristor valve. All elements are sufficiently rated, both thermally (to minimize the risk of overheating) and electrically (all other elements in parallel with the thyristor are defined with voltage ratings in excess of those of the best thyristor which could be encountered). The damping capacitors are of

oil-free construction. Therefore, the potential spread of a fire throughout the valve can be almost dismissed by the applied materials and components.

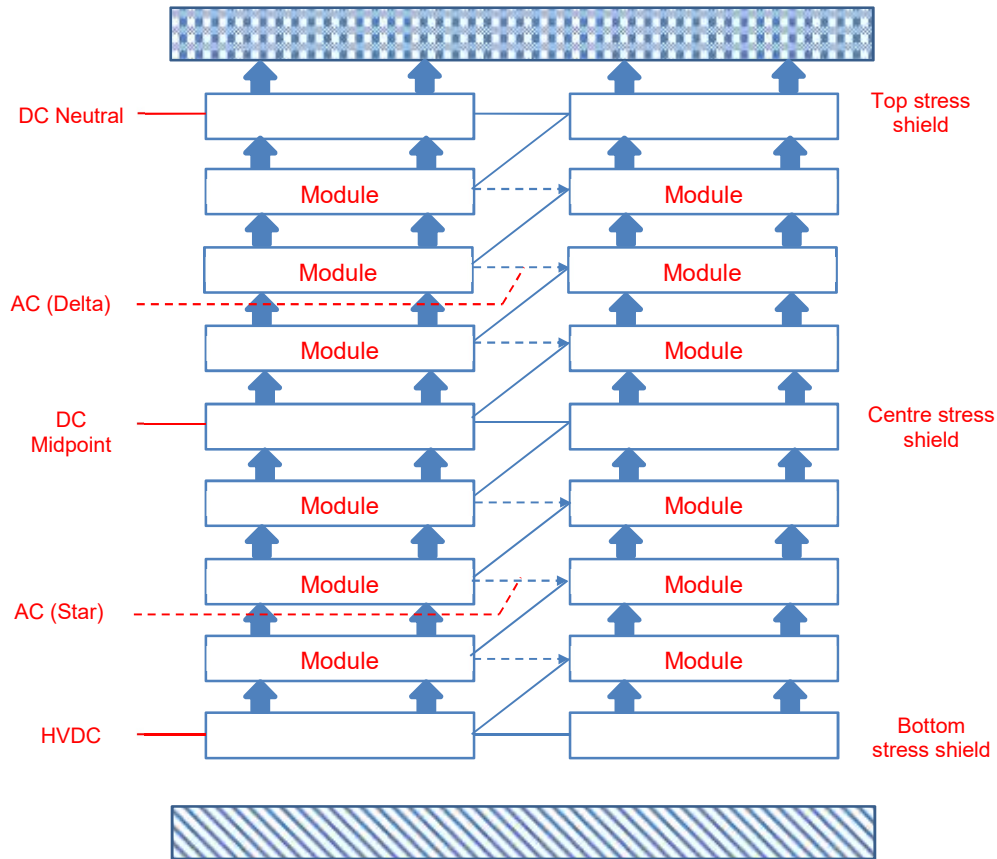

Figure 27. Common suspended MVU for HVDC

THYRISTOR VALVE COOLING CIRCUIT

In order to effectively extract the losses from the thyristors and other elements, and accomplish adequately low temperature increase in these elements, it is vital to provide some form of forced cooling circuit. Modern thyristor valves use liquid cooling by pure deionized water. It is safe with high voltage equipment as long as the water is ultra-pure, with no ionic contaminants. Deionizing devices ensure that the conductivity of the water is at a very low value. Water cooling is always provided for the thyristors and damping resistors, and typically also for the di/dt reactor and DC grading resistor. The water coolant is transferred in parallel to every thyristor level in the valve via insulating plastic pipes, and the waste heat is rejected to outdoor-mounted coolers. The water cooling circuit design is vital engineering task in order to ensure that the system has proper flow rates in all important areas and avoids excessively high flow rates that could cause erosion, or low flow rates that lead to accumulation of gas pockets. Although the water conductivity in a HVDC valve is typically extremely low, it is never zero, and

therefore, its potential for causing undesired electrochemical effects has been recognized. Ultrapure deionized water can have a very low conductivity, less than 0.1 $\mu\text{S}/\text{cm}$. Nevertheless, no matter how advanced the deionization devices, it is not feasible to decrease the conductivity completely to zero, because water always dissociates into H^+ and OH^- ions, to level controlled mainly by temperature. As a consequence, any water pipe crossing two points at different electrical potentials will inevitably transfer a small leakage current. When the used voltage is only AC, the consequences of this are not especially serious, but when the used voltage has a DC component, certain electrochemical reactions inevitably happen at the anode and cathode electrodes. Aluminum, which is commonly used as a heat sink material because of its great thermal conductivity, is very vulnerable to corrosion in the case that leakage currents flowing in the water are allowed to impinge directly on the aluminum. In order to stop damage to the aluminum, it is necessary to make sure that the leakage currents flowing in the water do not flow directly from water to aluminum but instead pass via inert electrode material. In this way the vulnerable aluminum is protected from damage. This process is presented in Figure 28.

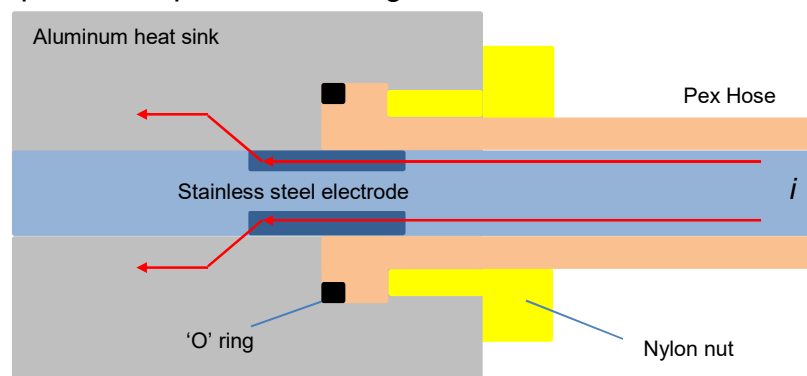

Figure 28. The protective electrode system applied in water cooled HVDC valves

HVDC CONVERTER TRANSFORMERS AND THEIR ARRANGEMENTS

The converter transformer works as the HVDC converter and the AC system interface and gives few functions including:

- Providing the precise voltage to the converters
- Providing galvanic isolation between the AC and DC systems
- Providing fault-limiting impedance
- Limiting effects of steady state AC voltage change on converter operating conditions (tap changer)
- Providing the 30° phase shift needed for twelve-pulse service via star and delta windings

AC transformer insulation is made to withstand AC voltage stresses. These voltage stresses are defined by the shape and insulation material permittivity that is used within the transformer. It is typically concentrated in the insulating oil. Nevertheless, converter transformers are exposed to AC voltage stress and DC voltage stress. DC voltage stress distribution is mainly determined by the resistivity of the insulating materials and therefore more stress is concentrated in the winding insulation than in the insulating oil. This resistivity changes due to few factors including the material temperature and the length of time the voltage stress is applied. This is why the internationally applied testing demands ask that the DC voltage stress be used for a period of time in order to ensure that a steady-state voltage stress distribution is accomplished. The converter transformer is the biggest plant item to be transferred to site for an HVDC project. Therefore, transport restrictions such as weight or height, if the transformer has to go over or under a bridge for example, can have a major impact on the selected converter transformer configuration. Figure 29 presents the typically recognized transformer arrangements in HVDC configurations.

Lowest cost can typically be accomplished by minimizing the number of components the converter transformer is broken down into. Therefore, the lowest cost is commonly a 3-phase, 3-winding transformer. Nevertheless, due to shipping limits, such a transformer may not be practical so another arrangement should be taken into account. Where a spare converter transformer is deemed necessary, based on an availability analysis of the arrangement, then it is more cost-effective to use a 1-phase, 3-winding transformer configuration, as one spare unit can replace any of the in-service units, whilst 2-winding arrangements need two spare units to be provided.

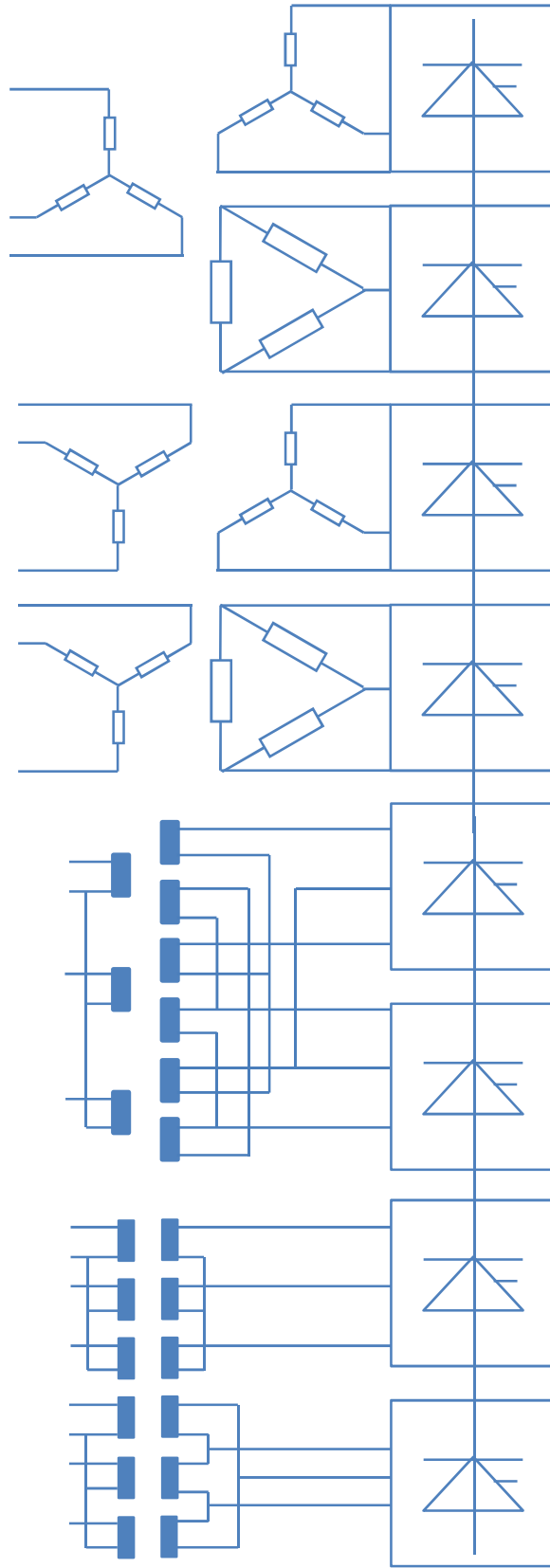

Figure 29. Common converter transformer configurations

Significant consideration in the converter transformer design is the selection of the leakage reactance as this will establish the major part of the converter's commutating reactance. The leakage reactance must mainly ensure that the maximum fault current that the thyristor valve can withstand is not surpassed. Nevertheless, beyond this limit, the choice of leakage reactance must be a balance of conflicting design issues, the most significant of which can be summarized as follows:

Lower impedance provides:

- Higher fault current
- Lower regulation drop
- Lower weight
- Taller core

Higher impedance provides:

- Lower fault current
- Higher regulation drop
- Higher weight
- Shorter core

Commonly the optimum leakage reactance will be in the range 0.12 pu to 0.22 pu.

HVDC CONVERTER RELIABILITY AND AVAILABILITY

Reliability and availability evaluation is the accepted way of assessing the HVDC converter scheme performance. CIGRE gathers reliability and availability of existing HVDC configurations from around the world and publishes a bi-annual report showing what performance is accomplished for those arrangements that give data for the report.

Reliability

Reliability is a measure of the HVDC link capability to transfer power above some minimum set value at any point in time under normal working conditions. Reliability is typically presented as the number of times in one year the configuration is incapable of transferring power above a minimum set value. This inability to transfer above a defined power level is termed Forced Outage Rate (F.O.R.).

Availability

“Availability” is not commercially important. For instance, if the configuration is unavailable during times of zero loading, the unavailability of the configuration will have no impact. Therefore, for HVDC configurations, the term is used to represent “energy availability”. Energy availability is the HVDC configuration ability to transfer, power up to the rated power. Therefore, a converter configuration which can transfer 1.0 pu power for 100% of the time would have an energy availability of 100%. Any HVDC configuration outage, for example, the outage of one pole in a bipole, will affect the energy availability, decreasing the figure to less than 100%.

CONVERTER STATION POWER LOSSES

Significant commercial consideration of any power interconnection is the electrical losses within the connection, that is, the power amount lost in the process of transferring the power from one location to another. Power losses within a line commutated converter arrangement are cautiously considered during the design phase in order to make sure that the relationship between capital equipment cost and the effective cost of losses can be optimized. In computing the losses effective cost, the purchaser must consider the duration of the financial plan for the HVDC link, the expected cost of electricity during this period and the anticipated interest rate during this period. By taking these figures, the net present value of the losses can be computed, that is, a figure which presents a cost to the owner of using the devices within the network. The loss assessment is typically assessed by multiplying a cost/kW figure by the HVDC supplier’s produced losses. Figures of 4,000 USD/kW to 5,000 USD/kW are typical. Figure 30 presents the common split between equipment within a HVDC transmission configuration whilst Figure 31 presents the split between devices for a back-to-back HVDC configuration.

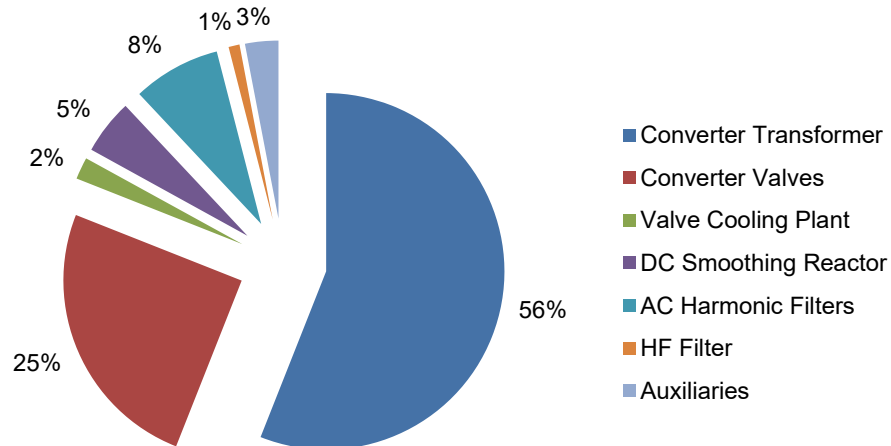

Figure 30. Common split of losses within an HVDC transmission configuration

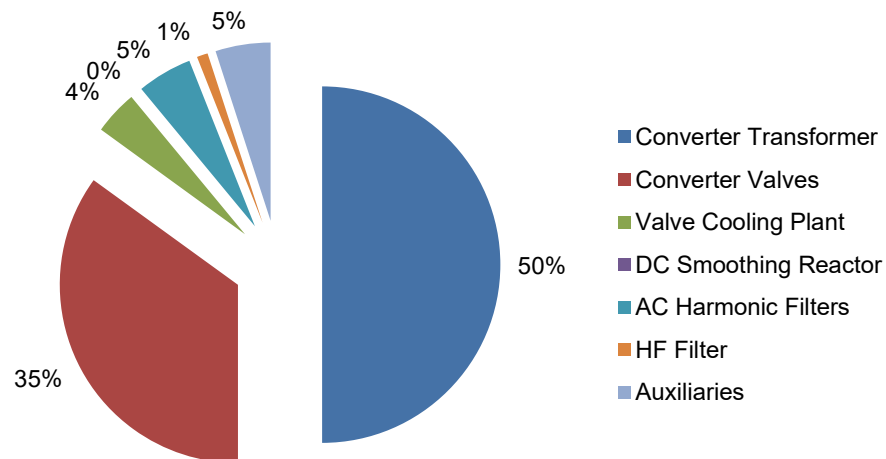

Figure 31. Common split of losses within a back-to-back HVDC configuration