



## AC Motor Protection

**Course Number:** EE-06-929

**PDH:** 6

**Approved for:** AK, AL, AR, FL, GA, IA, IL, IN, KS, KY, LA, MD, ME, MI, MN, MO, MS, MT, NC, ND, NE, NH, NJ, NM, NV, NY, OH, OK, OR, PA, SC, SD, TN, TX, UT, VA, VT, WI, WV, and WY

New Jersey Professional Competency Approval #24GP00025600

North Carolina Approved Sponsor #S-0695

Maryland Approved Provider of Continuing Professional Competency

Indiana Continuing Education Provider #CE21800088

Florida Provider #0009553 License #868

NYSED Sponsor #274

This document is the course text. You may review this material at your leisure before or after you purchase the course. In order to obtain credit for this course, complete the following steps:

- 1) Log in to My Account and purchase the course. If you don't have an account, go to New User to create an account.
- 2) After the course has been purchased, review the technical material and then complete the quiz at your convenience.
- 3) A Certificate of Completion is available once you pass the exam (70% or greater). If a passing grade is not obtained, you may take the quiz as many times as necessary until a passing grade is obtained (up to one year from the purchase date).

If you have any questions or technical difficulties, please call (508) 298-4787 or email us at [admin@PDH-Pro.com](mailto:admin@PDH-Pro.com).



## AC MOTOR PROTECTION

There is a wide range of AC motors since they can be used in numerous applications. AC motors need to be protected but protection selection usually does not depend on the motor and load type. This selection is based on the fundamental AC motor operation processes. There are crucial differences between the protection of induction motors and synchronous motors. Motor operation characteristics have to be particularly considered when applying selected protection. This approach is more important for the motors than for any other power system element. For example, the starting and stalling currents/times have to be known and taken into account when using overload protection. Also the thermal withstand of the AC motor has to be precisely defined under balanced and unbalanced loading conditions. The conditions for which AC motor protection is needed can be separated into two main groups: imposed external conditions and internal short circuits. Table 1 gives information of most likely issues that call for AC motor protection.

Table 1. Typical causes of motor faults

External failures	Internal failures
Reverse phase sequence	Bearing faults
Under-voltages	Winding failures
Single phasing	Overloads
Unbalanced supplies	

## MODERN RELAY MOTOR PROTECTION TECHNOLOGY

Modern numerical motor relay protection technology must be sufficient to meet protection requirements of any one of the vast range of motor designs. Many motors designs do not tolerate overloads. A motor protection relay providing sufficient protection will have the following set of characteristics:

## INDUCTION AND SYNCHRONOUS MOTORS

- extended start relay protection
- loss-of-load relay protection
- number of starts limitation
- stalling relay protection
- short circuit relay protection
- thermal relay protection

- earth fault relay protection
- negative sequence current detection
- winding RTD measurement/trip
- under-voltage relay protection
- auxiliary supply supervision

### **SYNCHRONOUS MOTORS IN PARTICULAR**

- loss of supply relay protection
- out-of-step relay protection

Also, protection relays may provide options such as circuit breaker condition monitoring assessment that can be used for maintenance needs. Manufacturers may also provide protection relays that use smaller number of functions in situations when less sophisticated relay protection is warranted (e.g. low rating asynchronous motors). The following paragraphs comment on possible motor fault types.

### **THERMAL (OVERLOAD) RELAY PROTECTION**

The majority of winding faults are either indirectly or directly triggered by overloading (prolonged or cyclic). Also winding faults can be caused by operation on unbalanced supply voltage, or single phasing. These effects cause excessive heating which deteriorates winding insulation and effectively creates electrical faults. Universally adopted rule is that insulation life is halved for each 10°C rise in temperature above the rated value. This rule is affected by the length of time spent at the higher temperature. As electric motors have a great heat storage capacity, it means that occasional short duration overloads may not adversely impact the motor. Nevertheless, prolonged overloads of only several percent may end in premature ageing and insulation fault. Next, the motor thermal withstand capacity is impacted by winding heating prior to a fault. Hence, it is crucial that the protection relay features consider extremes of zero and full-load pre-fault. These are known as the 'Cold' and 'Hot' conditions, respectively. Different motor designs, various usages, variety of different abnormal working conditions and resulting fault modes result in a complex thermal formula. Therefore, it is not possible to create universal mathematical model that is precise. Nevertheless, it is possible to make an approximate mathematical model. This model assumes that the motor is a homogeneous machine, producing and dissipating heat at a rate proportional to temperature rise. This rule

known as the motor 'thermal replica' is used for overload relay protection. The temperature  $T$  at any instant can be presented with:

$$T = T_{max} \left( 1 - e^{-\frac{t}{\tau}} \right)$$

Where

$T_{max}$  - Maximum/final steady state temperature

$\tau$  - heating time constant

Temperature rise is directly proportional to the current squared:

$$T = KI_R^2 \left( 1 - e^{-\frac{t}{\tau}} \right)$$

Where

$I_R$  - current which, if continuously transferred, generates temperature  $T_{max}$  in the motor.

Hence, it can be demonstrated that, for any overload current  $I$ , the allowable time  $t$  for this current to run is:

$$t = \tau \log_e \left[ \frac{1}{\left\{ 1 - \left( \frac{I_R}{I} \right)^2 \right\}} \right]$$

Typically, motor supply can comprise both positive and negative sequence components. Both current components produce motor heating. Hence, motor thermal replica should consider both components. Common equation for the resulting current is:

$$I_{eq} = \sqrt{(I_1^2 + KI_2^2)}$$

where

$I_1$  - positive sequence current

$I_2$  - negative sequence current

$K$  - negative sequence rotor resistance / positive sequence rotor resistance at nominal speed.

A common value of K is 3. Eventually, motor thermal replica has to consider the fact that the motor will cool down during light load periods. It also has to consider motor initial state. The motor has a cooling time constant,  $\tau_r$ , that specifies motor cooling rate. Therefore, the final motor thermal model can be defined as:

$$t = \tau \log_e \frac{(K^2 - A^2)}{(K^2 - 1)}$$

Where

$\tau$  – motor heating time constant

$$K = \frac{I_{eq}}{I_{th}}$$

$A^2$  – initial motor state (cold or hot)

$I_{th}$  – thermal setting current

Above equation considers motor ‘cold’ and ‘hot’ features as described in IEC 60255. Particular protection relays may use a dual curve feature for the motor heating time constant. In that case, two motor heating time constants are needed. Switching between the two constants starts at a pre-defined motor current. This method may be utilized to get enhanced tripping performance during motor starting with star-delta starter. During motor starting, the motor windings transfer full line current. However, in the ‘run’ condition, they transfer only 57% of the current detected by the protection relay. Also, when the motor is disconnected from the network, the motor heating time constant  $\tau$  is equal to the motor cooling time constant  $\tau_r$ . Since the protection relay should be perfectly matched to the protected motor and capable for sustained overload protection, a great range of protection relay adjustments is desirable. Common protection relay setting curves are presented in Figure 1.

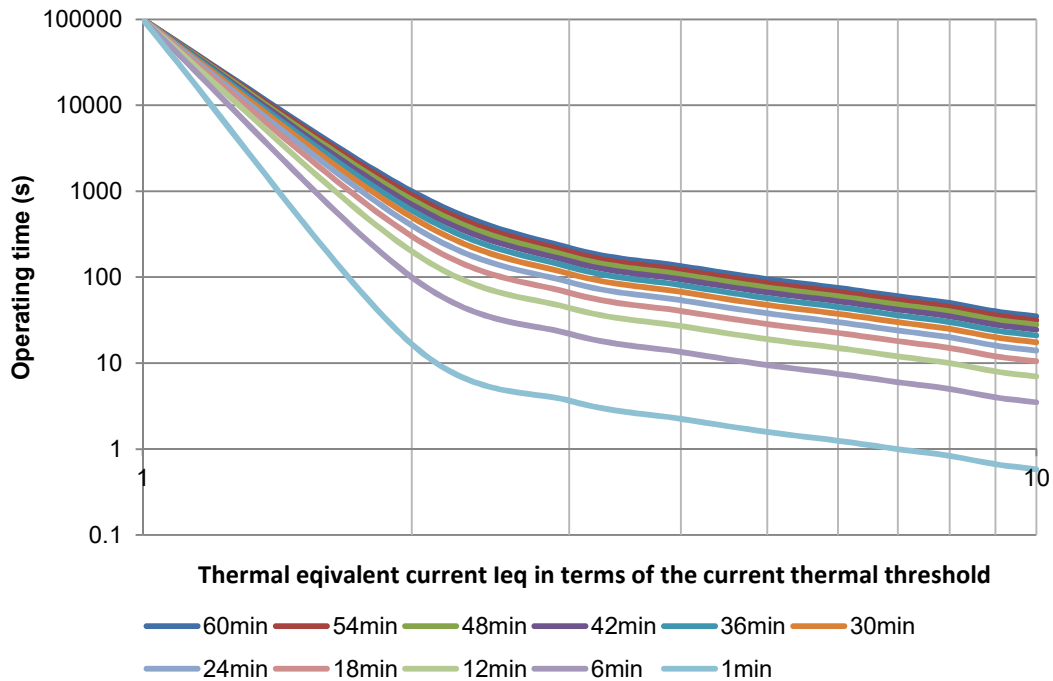

Figure 1. Thermal overload curves from cold – initial thermal state 0%

### START/STALL MOTOR PROTECTION

Once a motor starts, it takes a current greater than full load rating current. This lasts throughout the period that the motor needs to run-up to speed. Even though motor starting current decays as motor speeds up, in protection practice it is normal to assume that the motor current stays constant throughout the starting period. The starting current varies depending on the motor design and starting method. For direct-on-line (DOL) started motors, the nominal starting current can be 4-8 times of full-load current. Nevertheless, when a star-delta starter is used, the line current will be only  $1/\sqrt{3}$  of the DOL starting current. In the case motor stalls whilst running, or fails to start, due to great load, the motor will take a current equal to its locked rotor current. Hence, it is not possible to recognize stall condition and a healthy start solely on the basis of the taken current. Discrimination between the two conditions has to be made based on the duration of the taken current. For motors where the starting time is lower than the motor safe stall time, relay protection can be easily made. Nevertheless, in situations, where motors are used to power high inertia loads, the stall withstand time can be lower than the starting time. In these situations, extra methods have to be given to allow discrimination between the two conditions.

## PROLONGED START TIME/LOCKED ROTOR PROTECTION

A motor may fail to speed up for a number of different reasons:

- loss of a supply phase
- excessive load torque
- insufficient supply voltage
- mechanical issues

A huge current will be taken from the supply, and create high temperatures within the motor. This situation gets even worse since the motor is not rotating, so it cannot be cooled down due to rotation. Winding faults can quickly happen– either to the stator or rotor windings. This depends on the motor thermal limitations (In this respect, motors are differentiated as stator or rotor limited). The protection method changes depending on whether the starting time is lower than or higher than the safe stall time. In both situations, starting may be detected by motor feeder switch closure (contactor or circuit breaker). Optionally it can be detected if current rises above a starting current threshold value – commonly 200% of motor nominal current. Sometimes, both conditions can be detected only if they happen within a narrow time aperture. Additional conditions may exist for certain motor types placed in hazardous areas. Relay protection has to take these into account. Occasionally, a permissive interlock for machine pressurisation may be needed, and this can be conveniently accomplished by applying relay digital inputs and the built-in logic capabilities.

### CASE 1: START TIME LOWER THAN SAFE STALL TIME

Protection is accomplished by application of a definite time overcurrent option. Current setting is greater than full load current but is lower than the motor starting current. Relay time setting should be a slightly longer than the start time, but lower than the allowed motor safe starting time. Figure 2 shows successful start operation principle.

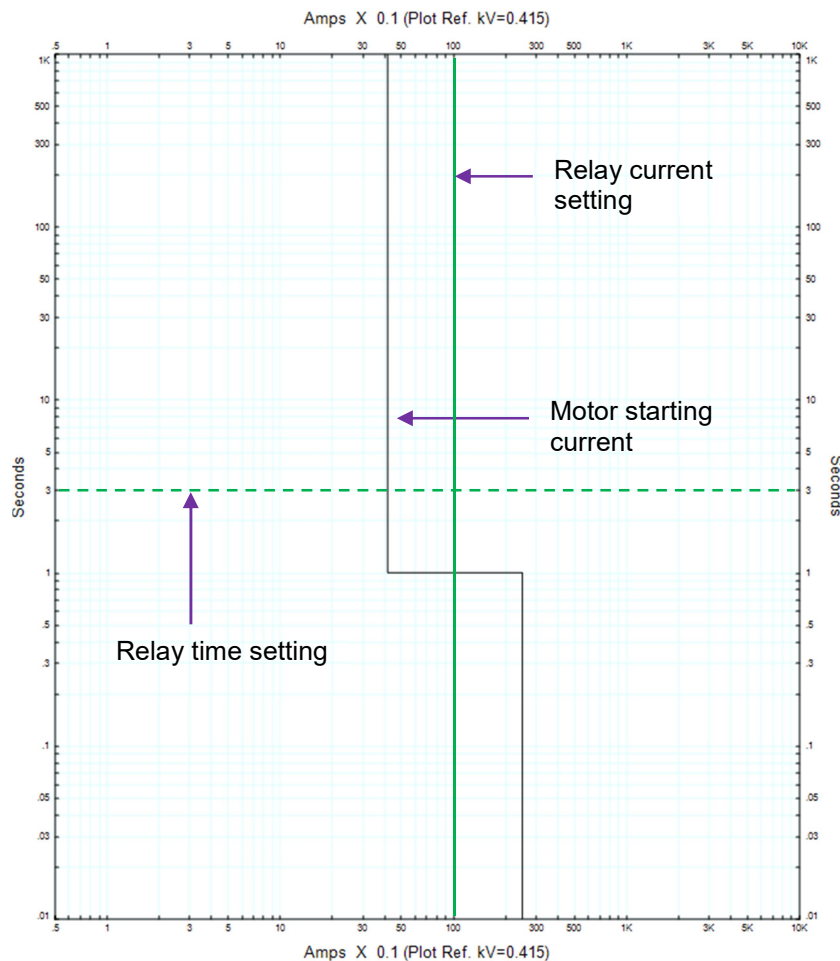

Figure 2. Successful start protection relay setting: start time lower than stall time

### CASE 2: START TIME GREATER OR EQUAL TO SAFE STALL TIME

In this situation, a definite time overcurrent option is not sufficient, since the needed delay time is greater than the motor maximum allowed starting time. Additional rotor movement detection, indicating a safe start, is needed. A speed-sensing switch typically gives this function. Successful start detection is used to choose the relay timer that is used for the safe run-up time of the motor. This time can be greater than the safe stall time due to decrease in current taken by the motor during the start. Also the rotor fans start to enhance machine cooling since motor accelerates. If a start is detected by the protection relay through monitoring current and/or start device closure, but the speed switch does not operate, the protection relay element uses the safe stall time setting to trip the motor before damage happens. Figure 3 shows operation principle for a successful and an unsuccessful start.



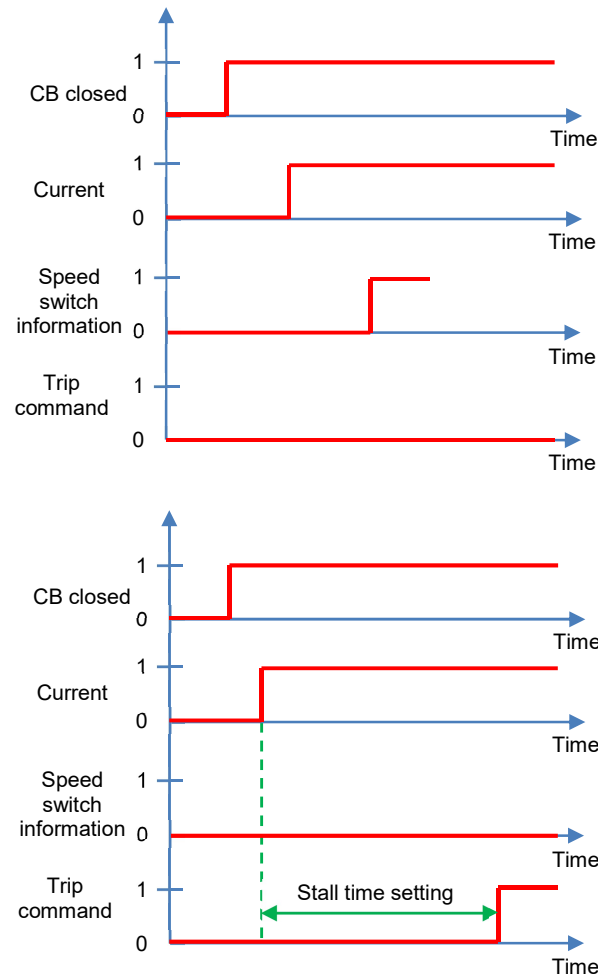

Figure 3. Protection relay setting for start time greater than stall time (a) Successful start (b) Unsuccessful start

### MOTOR STALL PROTECTION

In the case motor stalls or is unable to start due to huge load, it will take a current from the supply which is same as the locked rotor current. Apparently, it is preferred to prevent damage by disconnecting the motor as soon as possible. Motor stalling can be distinguished if the motor current exceeds the start current threshold after a successful start. For example, a motor start has been sensed and the motor current has decreased below the start current threshold within the motor safe start time. A subsequent increase in motor current above the motor starting current threshold indicates stall situation. If this condition continues for longer than the stall timer setting, tripping will happen. An instantaneous overcurrent protection relay device gives protection. In many electrical systems, transient voltage loss (normally up to 2 seconds) does not lead to designated motor tripping. These motors are allowed to re-accelerate upon supply restoration. During re-acceleration, which may take several seconds, they take a current which

is similar to the starting current. Hence, it is above the current threshold of the stall relay element.

The stall protection should function and defeat the object of the re-acceleration scheme. Therefore, motor protection relay will sense the presence of a voltage dip and recovery, and suppress stall protection for a defined time. Also, under-voltage protection device can be applied to sense the presence of the voltage dip and suppress stall protection for a defined time. Therefore, relay protection against stalled machines in case of an unsuccessful reacceleration is achieved. The time delay adjustment depends on the used re-acceleration arrangement and the features of particular motors.

### LIMIT ON NUMBER OF STARTS

Every motor has limitation on the number of allowable starts in a specified period without exceeding maximum allowable temperatures. Starting process should be stopped if the maximum number of starts is exceeded. Situation can be further complicated since the number of permitted 'hot' starts is less than the number of 'cold' starts, due to the differing initial motor temperatures. The protection relay must keep a separate count of 'cold' and 'hot' starts. By using information kept in the motor thermal replica, 'hot' and 'cold' starts can be recognized. Also time delay may be defined between consecutive starts to allow the motor to cool down (again recognizing 'hot' and 'cold' starts). The start inhibit is released after a time defined by the motor characteristics. The complete protection function is presented in the Figure 4.

In this particular example, the maximum start number within the Supervising Time has been reached; hence the Inhibit Start Time is started. The remaining time is greater than the Inhibit Start Time, therefore the start inhibition stays for a duration equal to the supervising time minus the  $t_n$ .

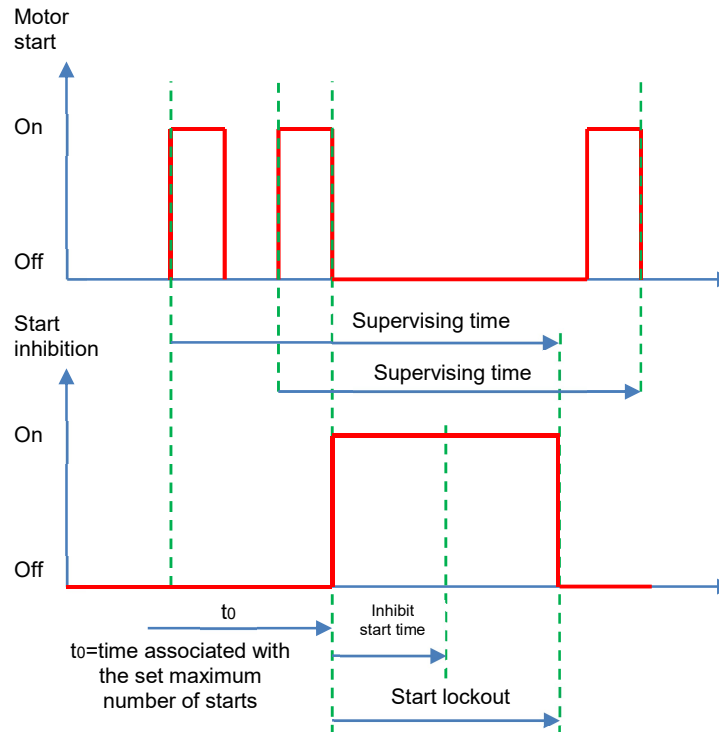

Figure 4. Limit on number of starts

## MOTOR SHORT-CIRCUIT PROTECTION

Motor short-circuit relay protection is usually supplied to cater for significant stator winding failures and terminal flashovers. Failures between phases rarely happen due to great amount of insulation between phase windings. Since the stator windings are totally enclosed in earthed metal the failure would soon involve ground, which would then trip the instantaneous earth fault protection. A single definite time overcurrent relay protection device is all that is needed for this application, programmed to about 125% of motor starting current. The time delay is needed to prevent spurious tripping due to CT spill currents. Time delay is usually around 100ms. In the case motor is supplied from a fused contactor, co-ordination with the fuse is needed. This coordination typically involves application of a long time delay. Since relay protection objective is to provide quick fault clearance to minimize fault damage, the protection is worthless in these situations. Therefore, it is only put up on motors that are fed via circuit breakers. Differential (unit) relay protection may be provided on larger HV motors fed via circuit breakers to protect against line-line and line-ground faults. The differential protection can be set sensitive allowing early fault detection, so that motor damage can be minimized. The normal definite time overcurrent protection is not sufficiently sensitive. Also sensitive ground fault protection may not be installed. The end user may avoid the detailed computations that are needed to obtain capacitance current. This current is needed to set

sensitive non-directional ground fault overcurrent protection. Also there may be no provision for a VT which would allow installation of directional sensitive ground fault protection. Nevertheless, non-directional ground fault overcurrent protection will usually be cheaper in situations where appropriate sensitivity can be provided.

## MOTOR GROUND FAULT PROTECTION

One of the most frequent motor failures is a stator winding fault. Regardless of the initial fault type (phase-phase, etc.) or the fault cause (cyclic overheating, etc.), surrounding metallic frame and casing will help that it quickly turns into a fault involving ground. Hence, provision of ground fault protection is very important. The type and sensitivity of used protection depends on the system grounding. However, it is common to provide instantaneous and time-delayed relay components to cater for major and slowly developing failures.

### SOLIDLY-GROUNDED SYSTEM

Solidly-grounded arrangements are dominant in LV systems mainly due to personnel safety. Two ground fault protection types are frequently used – depending on the needed sensitivity. Conventional ground fault protection using the residual CT connection can be applied for systems where sensitivity higher than 20% of motor continuous rated current is acceptable. This arrangement is shown in Figure 5. A lower limit is imposed on the setting by possible load unbalance and/or system capacitive currents.

Attention has to be taken to make sure that the protection relay does not trip from the spill current. Spill current can be a result of unequal CT saturation during motor start. In this case high currents will almost certainly saturate the motor CT's. Stabilizing resistor in series with the protection relay is frequently used, with the value being computed using the equation:

$$R_{stab} = \frac{I_{st}}{I_0} (R_{ct} + kR_1 + R_r)$$

Where:

$I_{st}$  – starting current referred to CT secondary

$I_0$  – relay ground fault setting (A)

$R_{stab}$  – stabilizing resistor value (ohms)

$R_{ct}$  – DC CT secondary resistance (ohms)

$R_1$  – CT single lead resistance (ohms)

- $R_r$  – relay resistance (ohms)
- $k$  – CT connection factor (1 for star point at CT, 2 for star point at relay)

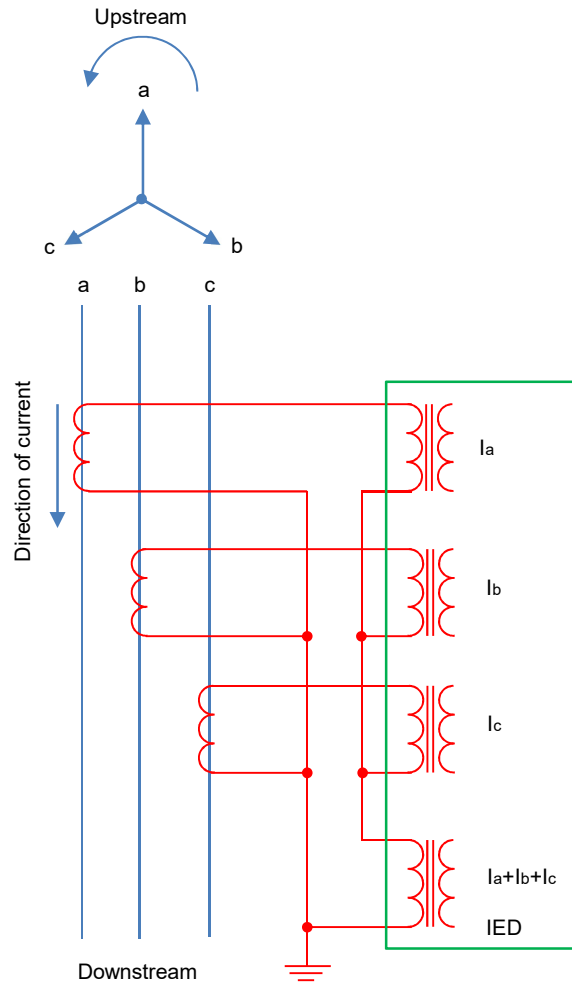

Figure 5. Residual CT arrangement for ground fault protection

The role of the stabilizing resistor is to increase the relay effective setting under these conditions, and therefore delay tripping. When a stabilizing resistor is applied, the tripping characteristic should be instantaneous. Alternatively, definite time delay characteristic can be applied to avoid the usage of a stabilizing resistor. The used time delay will have to be found by trial and error. It has to be sufficiently long to prevent maloperation during a motor start, but also short enough to give adequate protection in case of a fault. Co-ordination with other elements has to be taken into account. A frequent way of supplying a motor is via a fused

contactor. The contactor itself does not have a capacity to break fault current beyond a certain limit, which will typically be below the system maximum short circuit current. In these situations reliance is put on the fuse. As a trip command from the protection relay suggests the contactor to open, attention has to be taken to make sure that this does not happen until the fuse had time to operate. Figure 6 (a) presents incorrect grading of the protection relay with the fuse. In this case the protection relay operates first for a range of fault currents in excess of the contactor breaking capacity. Figure 6 (b) presents correct grading. Application of intentional definite time delay function may be required to achieve this.

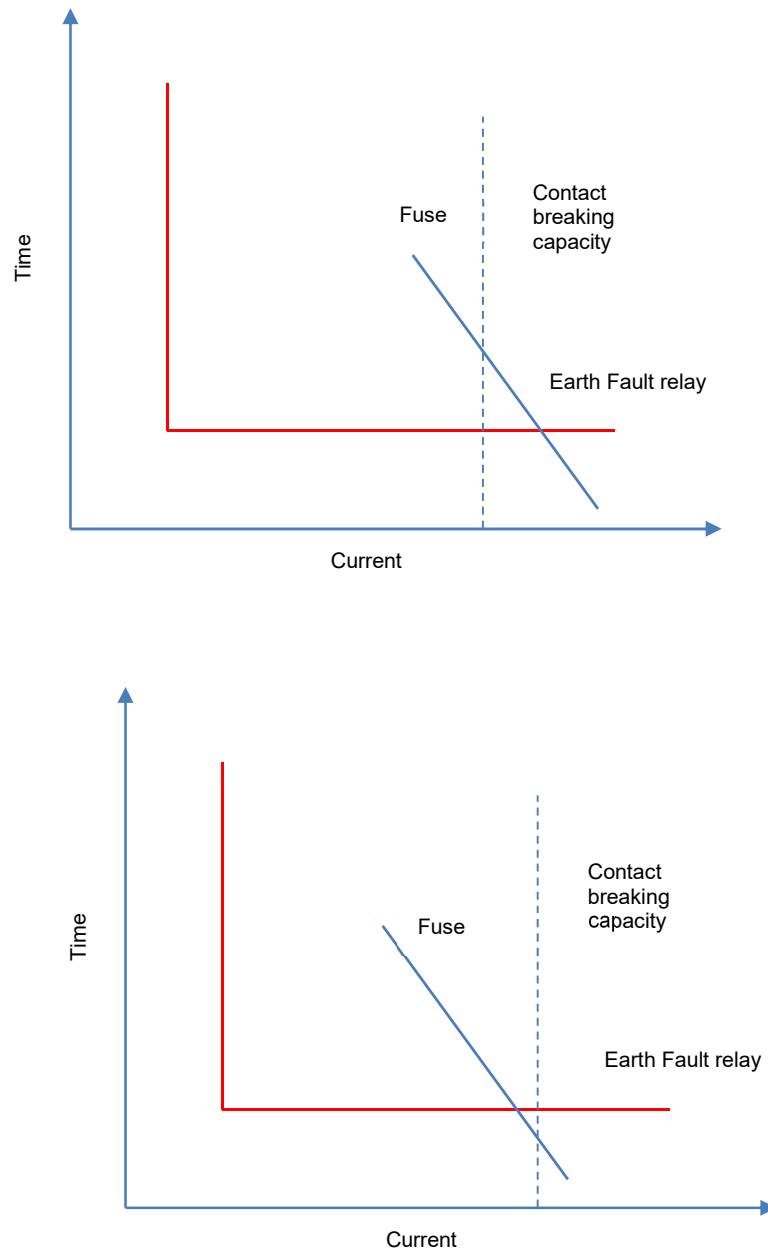

Figure 6. Grading of protection relay with fused contactor (a) Incorrect (b) Correct

If a more sensitive protection relay setting is needed, it is mandatory to use a core-balance CT (CBCT). This is a ring type CT. All phases of the motor supply plus the neutral on a four-wire system are passed through it. The CT turns ratio is no longer related to the expected normal line current. Magnetizing current requirements are also decreased, with only a single CT core to be magnetized instead of three. This allows application of low settings. Figure 7 presents the application of a core-balance CT. It also shows cable sheath routing to ensure proper operation in case of core-sheath cable failures.

### RESISTANCE-GROUNDED ELECTRICAL SYSTEMS

These are typically encountered on HV electrical systems, where the intention is to minimize damage caused by ground faults. This is done by limiting the ground-fault current that can flow. Resistance grounding can be achieved in two ways.

#### LOW RESISTANCE GROUNDING

In this arrangement, the value of resistance is selected to limit the short circuit current to a few hundred amps – values of 200A-400A being common. With CT's line residual connection, the minimum achievable sensitivity is about 10% of CT rated primary current. This is due to the possibility of CT saturation during starting. For a core-balance CT, the sensitivity that is feasible by using a simple non-directional ground fault relay protection element is limited to three times the steady-state feeder charging current. The setting should not be higher than about 30% of the minimum expected ground fault current. Apart from this, settings and time delay considerations are same as for solidly grounded systems.

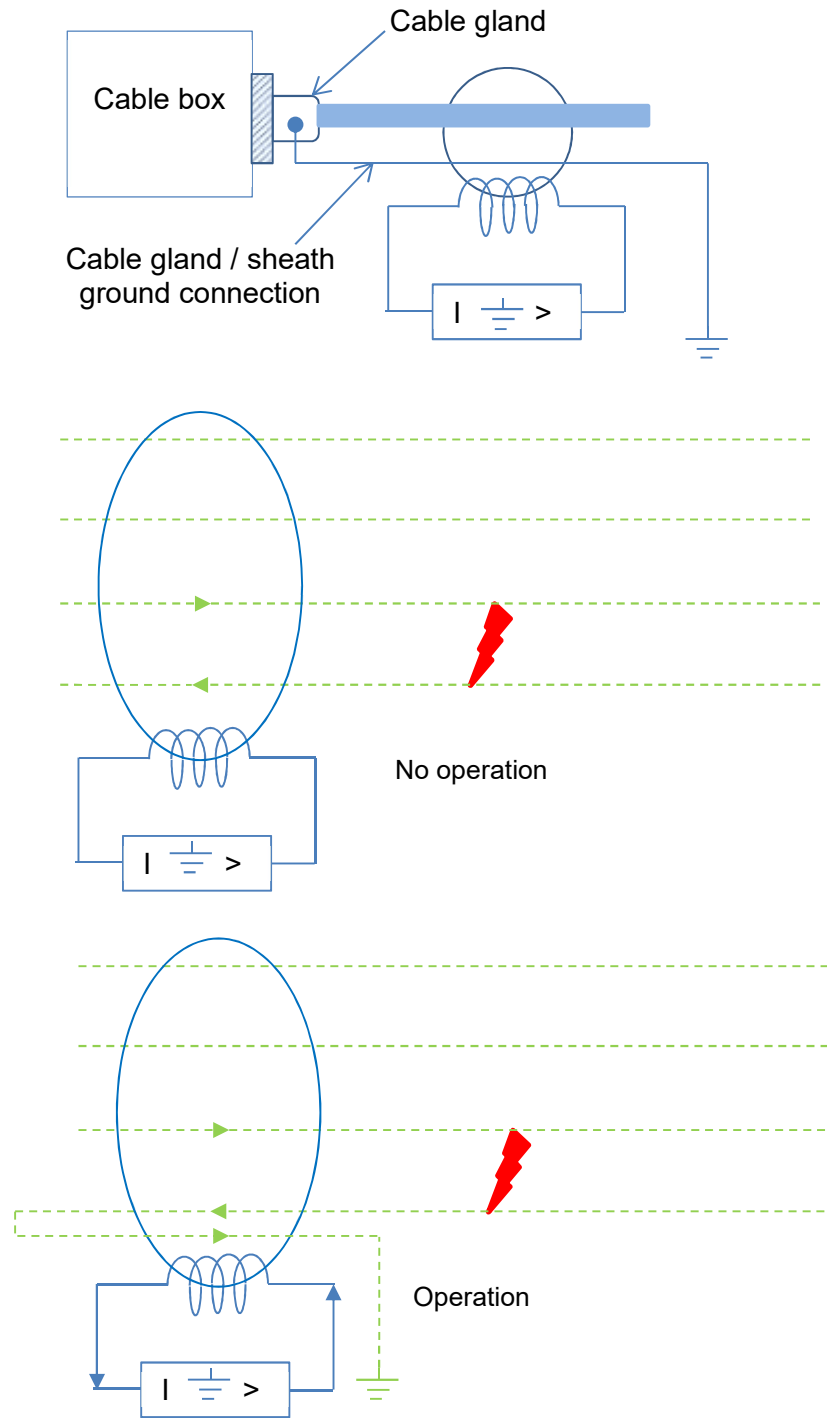

Figure 7. Usage of core-balance CT



## HIGH RESISTANCE GROUNDING

In particular HV electrical systems, high resistance grounding is applied to limit the ground fault current to several amps. In this situation, the electrical system capacitive charging current will stop applied sensitive ground fault protection, since the charging current amplitude will be comparable with the ground fault current. The solution is to apply a sensitive directional ground fault protection relay. A core balance CT is applied together with a VT measuring the system residual voltage, with a protection relay characteristic angle setting of  $+45^\circ$ . The VT has to be appropriate for the protection relay and hence the protection relay manufacturer should be consulted over appropriate types. Some protection relays need VT that is able to carry residual flux and this eliminates application of a 3-limb, 3-phase VT. Single phase capacitive charging current setting of 125% is possible using this approach. Applied time delay is not crucial but has to be sufficiently fast to quickly disconnect equipment in the case of a second ground fault that can happen right after the first. Minimal damage is caused by the first fault. However, the second effectively takes out the current limiting resistance from the fault path causing very high fault currents. Optional approach using residual voltage detection is also feasible.

## INSULATED GROUND SYSTEM

Ground fault detection causes problems on insulated ground systems since no ground fault current flows in the case of single ground fault. Nevertheless, detection is still important since over-voltages appear on healthy phases and it is vital to locate and clear the fault before a fault happens. Two techniques are possible:

- Detection of the resulting unbalance in system charging currents
- Residual overvoltage.

## SYSTEM CHARGING CURRENT UNBALANCE

Sensitive ground fault protection using a core-balance CT is needed for this arrangement. The principle is the same as already explained, except that the voltage is phase shifted by  $+90^\circ$  instead of  $-90^\circ$ . Figure 8 presents the current distribution in an insulated system subjected to a C phase to ground fault while the Figure 9 presents relay vector diagram. The residual current sensed by the protection relay is the sum of the charging currents going through the healthy part of the system plus the healthy phase charging currents on the faulted feeder. A protection relay setting of 30% of this value can be used to give protection without the risk of a trip due to healthy system capacitive charging currents. Since there is no ground fault current, it is possible to set the protection relay at site after intentionally applying ground faults at different parts of

the power system and measuring the resulting residual currents. If protection relay can be adjusted to a value between protected feeder charging current and the charging current for the rest of the system, the directional functionality is not needed.

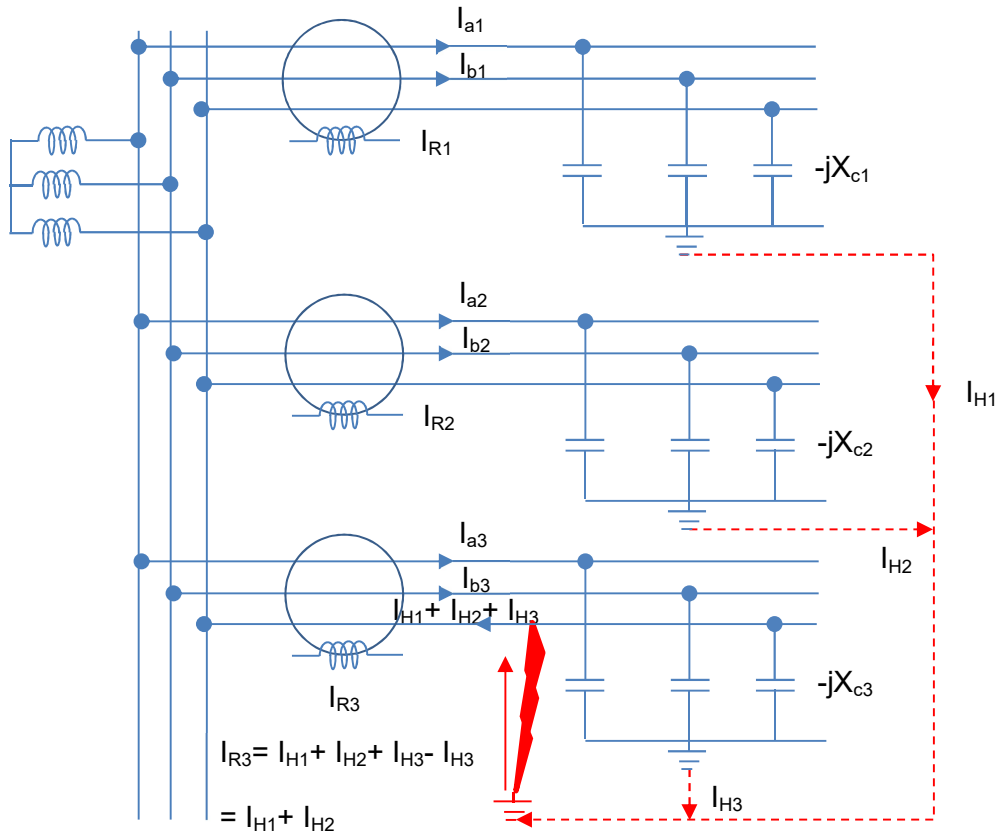

Figure 8. Current distribution in insulated-ground system for line-ground fault

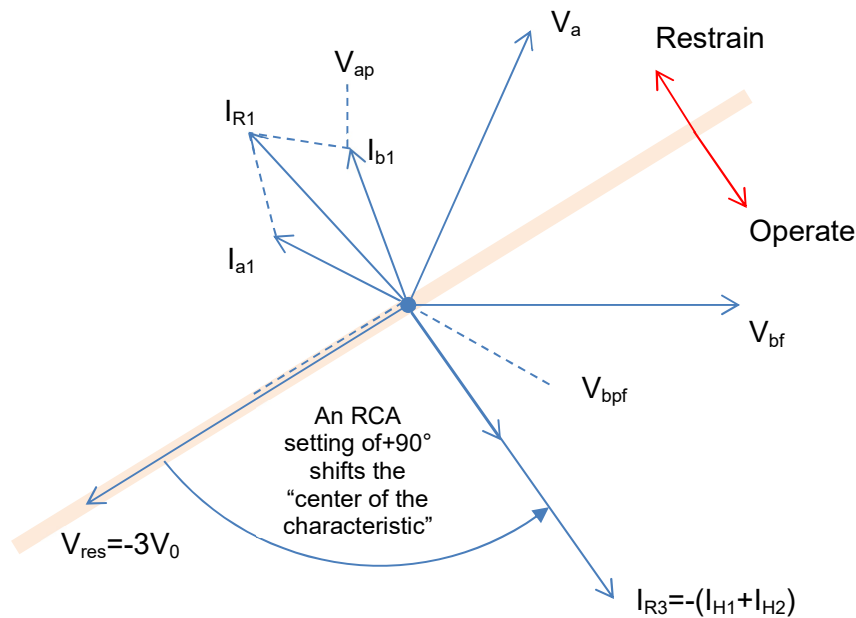
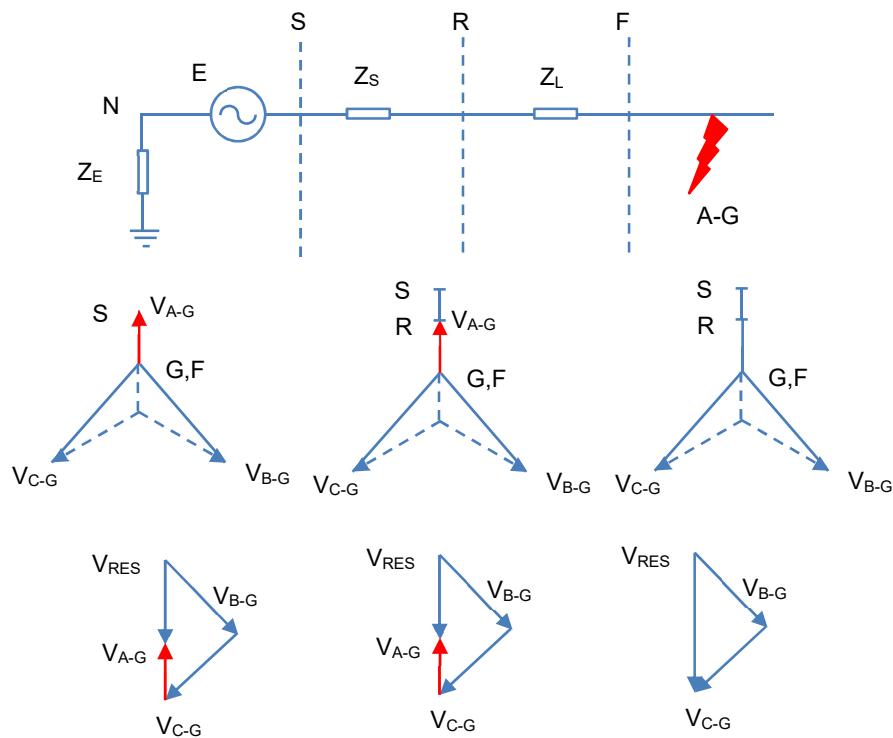

Figure 9. Protection relay vector graph

### RESIDUAL VOLTAGE TECHNIQUE

Ground to earth fault causes voltage rise between system neutral and the ground, and it can be detected by a protection relay measuring the residual system voltage. (Residual system voltage equals zero for a perfectly balanced, healthy system). Therefore CTs are not needed and this arrangement may be practical where provision of an extensive number of core-balance CTs is impossible or hard. This mainly happens due to physical constraints or limited budget. Selected VTs have to be suitable for the duty, therefore 3-limb, 3-phase VTs are not desirable. Protection relay typically has alarm and trip settings, each with adjustable time delays. Protection relay voltage setting can be computed using system grounding and impedances. Practical example for a resistance-grounded electrical system is presented in Figure 10. Protection relay grading has to be done with care, since the residual voltage will be sensed by all protection relays in the affected part of the system. Grading has to be completed with this in mind. Grading will be done on a time basis for providing alarms (1<sup>st</sup> stage), with a high set definite time trip to provide backup (2<sup>nd</sup> stage).



$$V_{RES} = \frac{Z_{SO} + 3Z_E}{2Z_{S1} + Z_{SO} + 2Z_{L1} + Z_{LO} + 3Z_E} \times 3E$$

Figure 10. Residual voltage ground-fault protection for resistance-grounded electrical system

### PETERSEN COIL GROUNDED ELECTRICAL SYSTEM

HV power system grounding using a reactor equal to the system shunt capacitance is known as Petersen Coil (or resonant coil) grounding. If this grounding method is used, a single ground fault results in zero ground fault current (for perfect balance between the grounding inductance and power system shunt capacitance). Therefore, the system can operate under these conditions for a substantial time until the fault is located and fixed.

## NEGATIVE PHASE SEQUENCE RELAY PROTECTION

Negative phase sequence current is generated from any unbalanced voltage condition. These situations include unbalanced loading, loss of a single line, or single-line faults. Single line faults are typically detected by ground-fault protection. Nevertheless, ground fault protection may not operate which depends on the fault location in a motor winding. The real value of the negative sequence current depends on the degree of unbalance in the supply voltage. It also depends on the ratio of the motor negative to the positive sequence impedance. The degree of unbalance depends on many components, but the negative sequence impedance is more easily determined. For the typical induction motor equivalent circuit (magnetizing impedance neglected) shown in Figure 11, motor positive sequence impedance at slip “s” can be calculated as:

$$= \left[ \left( \frac{R_{1P} + R_{2P}}{(2-s)} \right)^2 + (X_{1P} + X'_{2P})^2 \right]^{0.5}$$

Therefore, at standstill (s=1.0), positive sequence impedance is:

$$= [(R_{1P} + R'_{2P})^2 + (X_{1P} + X'_{2P})^2]^{0.5}$$

The motor negative sequence impedance at split s can be calculated as:

$$= \left[ \left( R_{1n} + \frac{R'_{2n}}{S} \right)^2 + (X_{1n} + X'_{2n})^2 \right]^{0.5}$$

And at normal operating speed, the impedance can be calculated as:

$$= \left[ \left( R_{1n} + \frac{R'_{2n}}{2} \right)^2 + (X_{1n} + X'_{2n})^2 \right]^{0.5}$$

where:

- suffix p presents positive sequence quantities

and

- suffix n presents negative sequence quantities

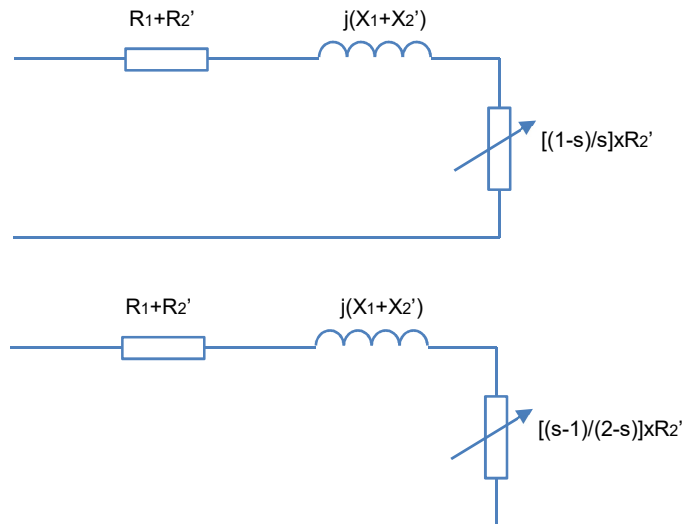

Figure 11. Induction motor equivalent circuits (a) Positive phase sequence equivalent circuit (b) Negative phase sequence equivalent circuit

In these calculations, the resistance can be ignored since it is small in comparison with the reactance. Therefore, the negative sequence reactance at running speed is roughly equal to the positive sequence reactance at standstill. Other way to present this is:

$$\frac{\text{positive seq. impedance}}{\text{negative seq. impedance}} = \frac{\text{starting current}}{\text{rated current}}$$

Starting current of a typical LV motor is 6 x full load current (FLC). Hence, a 5% negative sequence voltage (for example due to unbalanced system loads) would produce a 30% negative sequence current in the motor. This would eventually lead to excessive heating. For the same machine, negative sequence voltages in excess of 17% will end in a negative sequence current higher than rated full load current. Heating effect in the rotor of a given negative sequence current is greater than the same positive sequence current due to skin effect in the rotor. Therefore, negative sequence current may cause quick heating of the motor. Larger electric motors are more vulnerable in this regard, as the rotor resistance of such motors tends to be greater. Hence, relay protection against negative sequence currents is vital. Modern electric motor protection relays have negative sequence current measurement features, in order to

supply such protection. The level of negative sequence unbalance is greatly dependent on the fault type. In the case of a single phase failure at start, the negative sequence current equals 50% of the typical starting current. It is more challenging to give an estimate of the negative sequence current if loss of a phase happens while operating. This happens since the impact on the motor may change widely, from increased heating to stalling due to the decreased torque.

A common negative sequence current protection setting has to take into consideration the fact that the protected motor circuit may not be the source of the negative sequence current. Sufficient time should be granted for the adequate protection to clear the source of the negative sequence current without introducing risk of motor overheating. This requires a two stage tripping function, similar to overcurrent protection. A low-set definite time delay feature can be applied to give an alarm, with an IDMT feature applied to trip the motor in the case of higher levels of negative sequence current. Common settings might be 20% of CT rated primary current for the definite time element and 50% for the IDMT element. The IDMT time delay has to be selected to protect the electric motor while grading with other negative sequence protection relays. Some protection relays may not contain two elements. In that case the single element should be set to protect the electric motor, while grading should be a secondary consideration.

### **ROTOR WINDING FAULTS**

In the case of wound rotor electrical motors, certain degree of protection against faults in the rotor winding can be provided by an instantaneous stator current overcurrent relay element. As the starting current is typically limited by resistance to a maximum of twice full load, the instantaneous element can safely be set to about three times full load. In that case a slight time delay of approximately 30 milliseconds should be used. It should be clear that faults happening in the rotor winding would not be discovered by any differential protection applied to the stator.

### **RTD TEMPERATURE DETECTION**

RTDs are applied to assess temperatures of motor windings or shaft bearings. Temperature rise may refer to motor overloading, or the start of a fault in the affected part. A motor protection relay will hence have the capability of taking a number of RTD inputs and internal logic to start an alarm and/or trip when the temperature surpasses the appropriate set point. Sometimes, HV electric motors are supplied via a unit transformer, and in these situations, some of the electric motor protection relay RTD inputs may be assigned to the transformer winding

temperature RTDs. In those cases they provide over transformer temperature protection without the use of a separate protection relay.

### BEARING FAILURES

Two types of bearings have to be analyzed: the antifriction bearing (ball or roller), used typically on small motors (up to around 350kW), and the sleeve bearing, used mainly on large electric motors. The failure of ball or roller bearings typically happens very quickly, causing the electric motor to come to a standstill as parts of the damaged roller get entangled with the others. Therefore there is small chance that any protection relay functioning from the input current can discover bearing failures of this type before the bearing is totally destroyed. Hence, protection is limited to quickly disconnecting the stalled motor to avoid further damage. Failure of a sleeve bearing can be discovered by means of a rise in bearing temperature. The normal thermal overload protection relays cannot give adequate protection to the bearing itself but will function to protect the electric motor from excessive damage. Application of RTD temperature detection can give adequate protection since it would allow investigation into the cause of the bearing running hot prior to complete collapse.

### UNDERVOLTAGE PROTECTION

Electric motors may stall when exposed to sustained under-voltage conditions. Transient under-voltages will typically allow a motor to recover when the voltage is fixed, unless the power supply is weak. Electric motors fed by contactors have inherent under-voltage protection, unless a latched contactor is applied. Where a particular under-voltage trip is needed, a definite time under-voltage element is applied. If two elements are given, alarm and trip settings can be applied. An interlock with the motor starter is needed to block relay function when the starting element is open, otherwise a start will never be allowed. The voltage and time delay settings depend on the particular system. They must allow for all voltage dips likely to happen on the system during transient faults, motor starts, etc. to avoid spurious trips. Since motor start can lead to voltage depression to 80% of nominal, the voltage setting is likely to be below this figure. Re-acceleration is typically possible for voltage dips lasting between 0.5-2 seconds. However, this depends on electrical system, motor and drive characteristics, and hence the time delay will be set bearing these factors in mind.

### LOSS-OF-LOAD PROTECTION

Loss-of-load protection has a number of possible features. It can be applied to protect a pump against becoming unprimed, or to stop a motor in case of a failure in a mechanical transmission (e.g. conveyor belt). Also it can be applied with synchronous motors to protect against loss-of-



supply conditions. Implementation of the function is by a low forward power relay element, interlocked with the motor starting element to prevent operation when the motor is tripped and therefore preventing a motor start. When starting against a very low load (e.g. a compressor), the protection function may also need to be suppressed for the duration of the start, to prevent maloperation. The protection setting will be affected by the function to be performed by the protection relay. A time delay may be needed after pickup of the protection element to prevent operation during system transients. This is particularly important for synchronous motor loss-of supply protection.

### EXTRA PROTECTION FOR SYNCHRONOUS MOTORS

The differences in construction and operational features of synchronous motors mean that extra protection is needed for these motor types. This extra protection is described in the following sections.

#### OUT-OF-STEP PROTECTION

A synchronous electric motor may slow down and lose synchronism (fall out-of-step) if a mechanical overload exceeding the peak motor torque happens. Other conditions that may cause this situation are a fall in the applied voltage to stator or field windings. Such a fall may not need to be extended. Voltage dip of a few seconds could be sufficient. An out-of step condition causes the electric motor to take excessive current and create a pulsating torque. Even if the cause is promptly eliminated, the electric motor will likely not recover synchronism and will finally stall. Therefore, it must be disconnected from the supply. The current drawn during an out-of-step condition is at a very low power factor. Therefore a protection relay element that reacts to low power factor can be applied to give protection. The element must be suppressed during start, when a similar low power factor condition happens. This can conveniently be accomplished by use of a definite time delay, set to a value slightly higher of the motor start time. The power factor setting will change depending on the motor rated power factor. Commonly, it would be 0.1 less than the motor rated power factor i.e. for a motor rated at 0.85 power factor, the setting would be 0.75.

#### PROTECTION AGAINST SUDDEN SUPPLY RESTORATION

If the supply to a synchronous motor is cut off, it is vital that the electric motor breaker is tripped as quickly as possible. This is even more important in the case there is any chance of the supply being automatically fixed. This is essential in order to prevent the supply being restored out of phase with the motor generated voltage. Two methods are typically used to discover this condition, in order to cover different motor operating modes.

## UNDERFREQUENCY PROTECTION

The under frequency protection relay element will function in the case of the supply failing when the motor is on load, which causes the motor to quickly slow down. Generally, two elements are given, for alarm and trip indications. The under-frequency setting value has to consider the power system features. In some power systems, prolonged periods of operation at frequencies substantially below normal happen and they should not result in a motor trip. The minimum safe operating frequency of the motor under load conditions must hence be determined, along with minimum system frequency.

## LOW FORWARD POWER PROTECTION

This protection can be used in conjunction with a time delay to discover a loss-of-supply condition when the electric motor may share a busbar with other loads. The motor may try to supply the other loads with power from the stored kinetic energy of rotation. A low-forward-power protection relay can discover this condition. A time delay will be needed to prevent service during system transients leading to momentary reverse power flow in the motor.

## MOTOR PROTECTION EXAMPLES

This section provides HV and LV induction motor protection examples.

### HV MOTOR PROTECTION

Table 2 presents relevant parameters of a HV induction motor that needs to be protected. Presented motor is protected using MiCOM P241 relay. The most important protection settings are calculated in the following paragraphs.

Table 2. HV motor characteristics

Parameter	Value
Rated output (kW) – CMR	1000
Rated frequency (Hz)	50
Rated voltage (kV)	3.3
System earthing	Solid
Rated power factor/efficiency	0.9/0.92
Control device	Circuit breaker
Stall withstand time cold/hot (sec)	20/7
Starting current (%)	550 DOL
Permitted starts cold/hot	3/2
CT ratio	250/1
Start time at 100% voltage (sec)	4
Start time at 80% voltage (sec)	5.5
Heating/cooling time constant (min)	25/75

### MOTOR THERMAL PROTECTION

The current setting  $I_{TH}$  is same as the induction motor full load current, since it is a CMR rated (Continuous Maximum Rated) motor. Motor full load current equals to 211A, hence (in secondary quantities):

$$I_{TH} = \frac{211}{250} = 0.844$$

Value of 0.85 should be used or nearest available setting. The protection relay has a parameter, K that gives provision for the increased heating effect due to negative sequence currents. If no other information is available, value of K=3 should be used. Two thermal heating time constants are given,  $\tau_1$  and  $\tau_2$ .  $\tau_2$  is used for starting methods other than DOL, otherwise  $\tau_1$  should be used.  $\tau_1$  is set to the heating time constant, therefore  $\tau_1 = \tau_2 = 25\text{min}$ . Cooling time constant  $\tau_R$  is set as a multiple of  $\tau_1$ . With a cooling time constant of 75min,  $\tau_R = 3 \times \tau_1$ .

### SHORT CIRCUIT MOTOR PROTECTION

Presented HV motor has a starting current of 550% of full load current. In that case, the short-circuit function is set to  $1.25 \times 5.5 \times 211\text{A} = 1450\text{A}$ . In terms of the protection relay nominal current  $I_n$ , the setting value equals to:

$$\frac{1450}{250} = 5.8I_n$$

There is a minimum time delay of 100ms for currents up to 120% of setting to give provision for transient CT saturation during start. Also there is 40ms time delay above this current value. These adjustments are acceptable.

### GROUND-FAULT MOTOR PROTECTION

It is assumed that no core balance current transformer (CBCT) is installed. A common setting of 30% of motor rated current is applied, leading to ground fault relay setting of

$$0.3 \times \frac{211}{250} = 0.25I_n$$

A stabilizing resistor is needed to prevent maloperation due to CT spill current. This may happen during start as the CTs may saturate. Instantaneous tripping is allowed with the installed stabilizing resistor. The other option is to leave out the stabilizing resistor and apply a definite time delay along with the ground-fault device. Nevertheless, the time delay has to be found by trial and error during commissioning.

### LOCKED ROTOR/EXCESSIVE START TIME MOTOR PROTECTION

The current element has to be adjusted in excess of the motor rated current, but well below the motor starting current to make sure that a start condition is recognized (this can also be accomplished by using an auxiliary contact on the motor CB which is wired to the protection relay). A setting of 500A ( $2I_n$ ) is appropriate. The time delay has to be set longer than the start time, but less than the cold stall time. Value of 15s is recommended.

### STALL MOTOR PROTECTION

For motor stall protection, the same current setting as for locked rotor protection can be applied – 500A. The time delay needs to be less than the hot stall time of 7s but higher than the start time by a comfortable margin to prevent a spurious trip in the case start time is a little longer than anticipated. Value of 6.5s is recommended. The protection characteristics are presented in Figure 12.

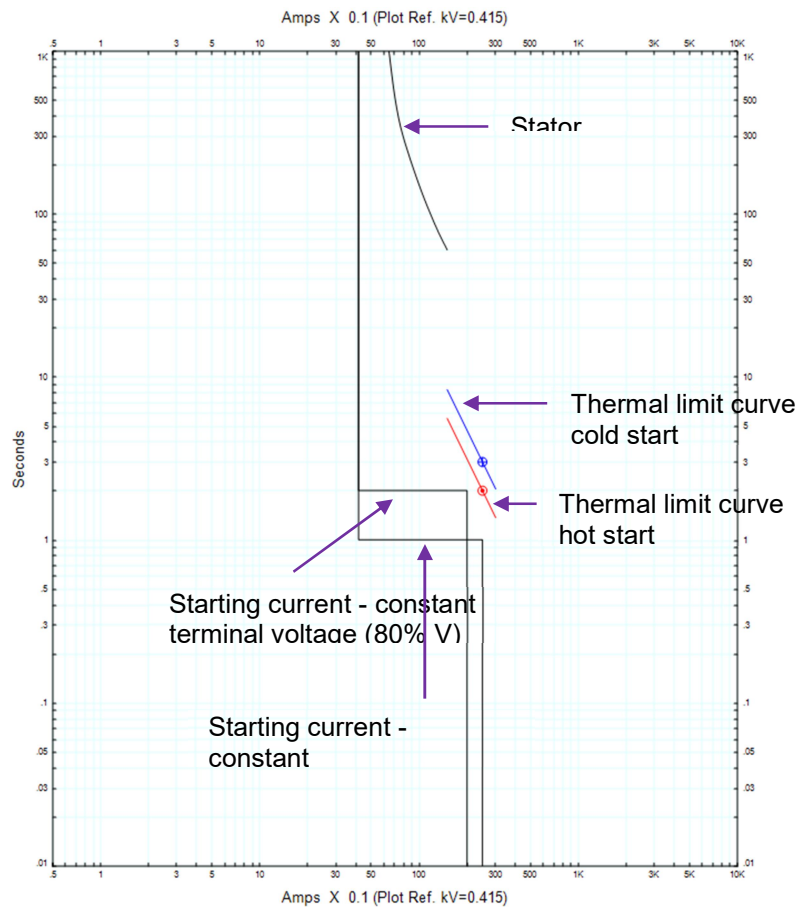

Figure 12. Motor protection characteristics for motor protection example

### NEGATIVE PHASE SEQUENCE PROTECTION

Two protection elements are given, the first is definite time delayed to give an alarm. The second is an IDMT protection element applied to trip the motor on high levels of negative sequence current, such as would happen on a loss of phase condition at start. Use a setting of 20% with a time delay of 30s for the definite time element and 50% with a TMS of 1.0 for the IDMT element. The resulting curve is presented in Figure 13. The motor thermal protection, as it uses a negative sequence component, is applied for protection of the motor at low levels of negative sequence current.

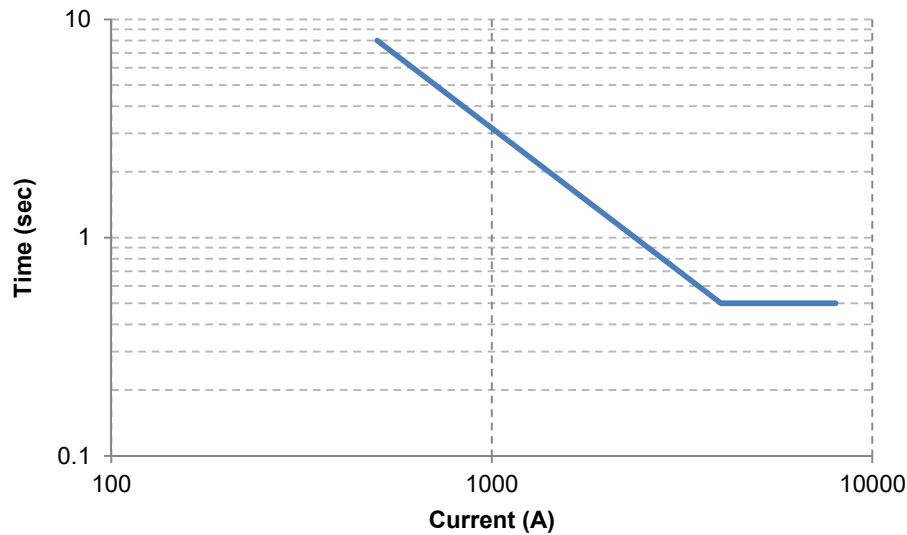

Figure 13. Motor protection example – negative sequence protection function

### OTHER PROTECTION CONSIDERATIONS

If the protection relay can be provided with an adequate voltage signal, stall protection can be suppressed during re-acceleration after a voltage dip using the under-voltage element (set to 80-85% of rated voltage). Under-voltage protection (set to around 80% voltage with a time delay of up to several seconds, dependent on system characteristics) and reverse phase protection can also be used to give extra protection. Unless the drive is vital to the process, it is not justifiable to provide a VT specially to enable these characteristics.

### LV MOTOR PROTECTION

LV motors are typically supplied via fused contactors and hence the tripping times of a protection relay for overcurrent must be carefully co-ordinated with the fuse to ensure that the contactor does not try to break a current in excess of its rating. Table 3 provides details of an LV motor and related fused contactor.

Table 3. LV motor protection setting example

Parameter	Symbol	Figure	Unit
(a) LV motor example			
Standard		IEC 60034	
Motor Voltage		400	V
Motor kW		75	kW
Motor kVA		91.45	kVA
Motor FLC		132	A
Starting current		670	%
Starting time		4.5	Sec
Contact rating		300	A
Contact breaking capacity		650	A
Fuse rating		250	A
(b) Relay settings			
Overcurrent		Disabled	
Overload setting	$I_b$	4.4	A
Overload time delay	$I > t$	15	Sec
Unbalance	$I_2$	20	%
Unbalance time delay	$I_2 > t$	25	sec
Loss of phase time delay	$< I_p$	5	sec

### OVERCURRENT (SHORT-CIRCUIT) PROTECTION

The fuse gives the motor overcurrent protection, as the protection relay cannot be allowed to trip the contactor on overcurrent in case the current exceeds the contactor breaking capacity. The feature for overcurrent protection within the protection relay is hence disabled.

### THERMAL (OVERLOAD) MOTOR PROTECTION

For the existing motor no information exists except the standard information given in the manufacturer's catalogue. This information does not include motor thermal (heating) time constant. In these situations, it is common to adjust the thermal protection so that it lies just above the motor starting current. The current setting of the relay,  $I_b$ , is determined using the equation:

$$I_b = 5 \times \frac{I_n}{I_p}$$

Where

$I_n$  – motor rated primary current

$I_p$  – CT primary current

Therefore,

$$I_b = 5 \times \frac{132}{150} = 4.4 \text{ A}$$

Relay thermal time constant with motor initial thermal state of 50% is 15s. Motor starting current is 670% of nominal. This is shown in Figure 14.

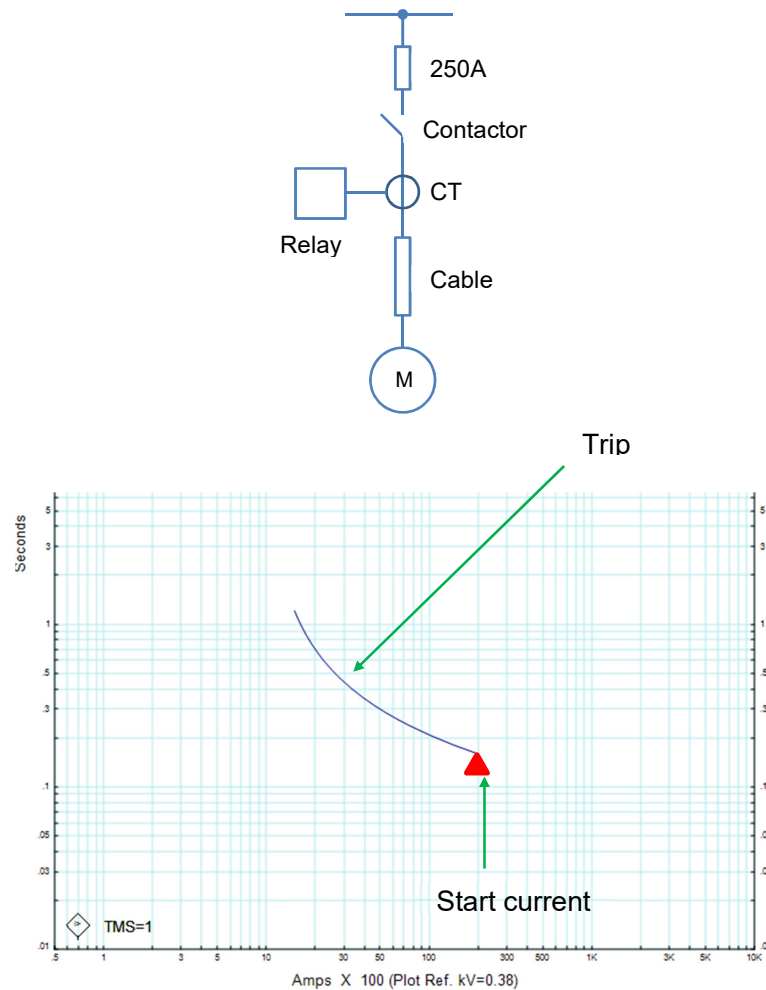

Figure 14. Motor protection example – contactor – fed motor (a) LV motor protection – contactor fed example (b) Protection relay trip characteristic

### **NEGATIVE SEQUENCE (PHASE UNBALANCE) MOTOR PROTECTION**

The motor is designed according to IEC standards that allow a negative sequence (unbalance) voltage of 1% on a continuous basis. This leads to roughly 7% negative sequence current in the motor. Since the protection relay is equipped only with a definite time relay component, a setting of 20% is adequate, with a time delay of 25s. This setting allows for short high-level negative sequence transients.



## LOSS OF PHASE PROTECTION

The protection relay has a separate component for this protection. Loss of a line increases large negative sequence currents, and hence a shorter time delay is needed. A definite time delay of 5s is recommended. The relay settings are summarized in Table 3 (b).