



HVDC Technology - Part 1

Course Number: EE-06-932

PDH: 6

Approved for: AK, AL, AR, FL, GA, IA, IL, IN, KS, KY, LA, MD, ME, MI, MN, MO, MS, MT, NC, ND, NE, NH, NJ, NM, NV, NY, OH, OK, OR, PA, SC, SD, TN, TX, UT, VA, VT, WI, WV, and WY

New Jersey Professional Competency Approval #24GP00025600

North Carolina Approved Sponsor #S-0695

Maryland Approved Provider of Continuing Professional Competency

Indiana Continuing Education Provider #CE21800088

Florida Provider #0009553 License #868

NYSED Sponsor #274

This document is the course text. You may review this material at your leisure before or after you purchase the course. In order to obtain credit for this course, complete the following steps:

1) Log in to My Account and purchase the course. If you don't have an account, go to New User to create an account.

2) After the course has been purchased, review the technical material and then complete the quiz at your convenience.

3) A Certificate of Completion is available once you pass the exam (70% or greater). If a passing grade is not obtained, you may take the quiz as many times as necessary until a passing grade is obtained (up to one year from the purchase date).

If you have any questions or technical difficulties, please call (508) 298-4787 or email us at admin@PDH-Pro.com.



INTRODUCTION TO HVDC

Electricity is produced as an alternating current (AC). It is also transferred and distributed as AC and in majority of applications it is used as AC. Nevertheless, in many situations, it is financially and technically beneficial to use direct current (DC) links. In some situations, it may be the only possible power transmission method. In situations, when two different AC systems cannot be synchronised or when the interconnection cable length is too long for stable AC transmission, DC transmission can be applied. At sending “converter station” the AC is converted to DC current, which is then transferred to a second, receiving converter station and converted back to AC. In “back-to-back” HVDC arrangements the two converter stations are placed in the same building, reducing the DC transmission length to zero. HVDC transmission installations can be classified into four broad groups and any arrangement typically involves a combination of two or more of these. The groups are:

- Transfer of bulk power where AC would be uneconomical or infeasible
- Link between electrical systems which use different frequencies, or between non-synchronised or isolated power systems which, even though they have the same nominal frequency, cannot be run reliably in synchronism.
- Introduction of power infeed without greatly increasing the short circuit level of the client’s AC system.
- Improvement of AC system operation by the fast and precise control of HVDC power.

HVDC ARRANGEMENTS

MONOPOLAR HVDC CONFIGURATIONS

Monopolar HVDC configurations have either earth return or metallic return.

A Monopolar HVDC configuration with earth return contains one or more six-pulse

converter units connected in series or parallel at each end, a single conductor and return through the ground or sea. This configuration is presented in Figure 1. It can be a practical arrangement for a HVDC cable transmission and/or the first stage of a bipolar scheme. At each line end, it demands an electrode line and a earth or sea electrode built for continuous service.

A Monopolar HVDC configuration with Metallic Return typically contains one high voltage and one medium voltage conductor as presented in Figure 2. A monopolar scheme is used either as the first stage of a bipolar arrangement, avoiding earth currents. It is also applied when installation of electrode lines and earth electrodes results in an uneconomical solution due to a short distance or high value of ground resistivity.

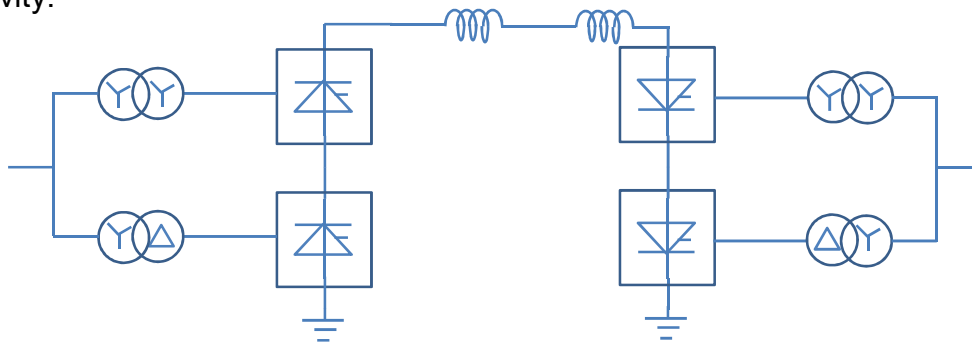

Figure 1. Monopolar HVDC arrangement with earth return

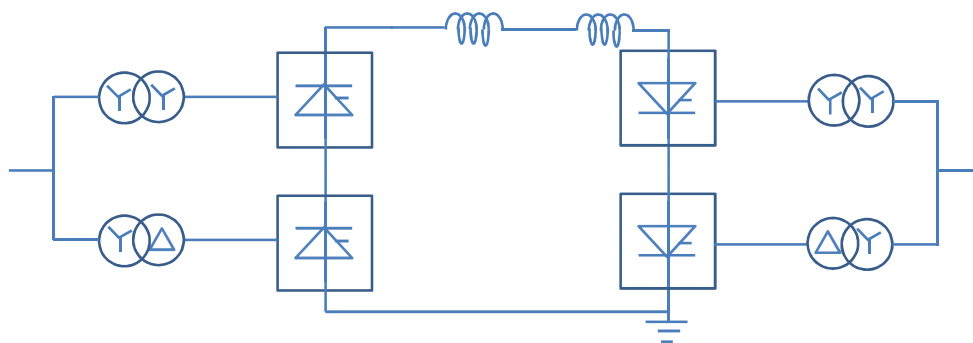
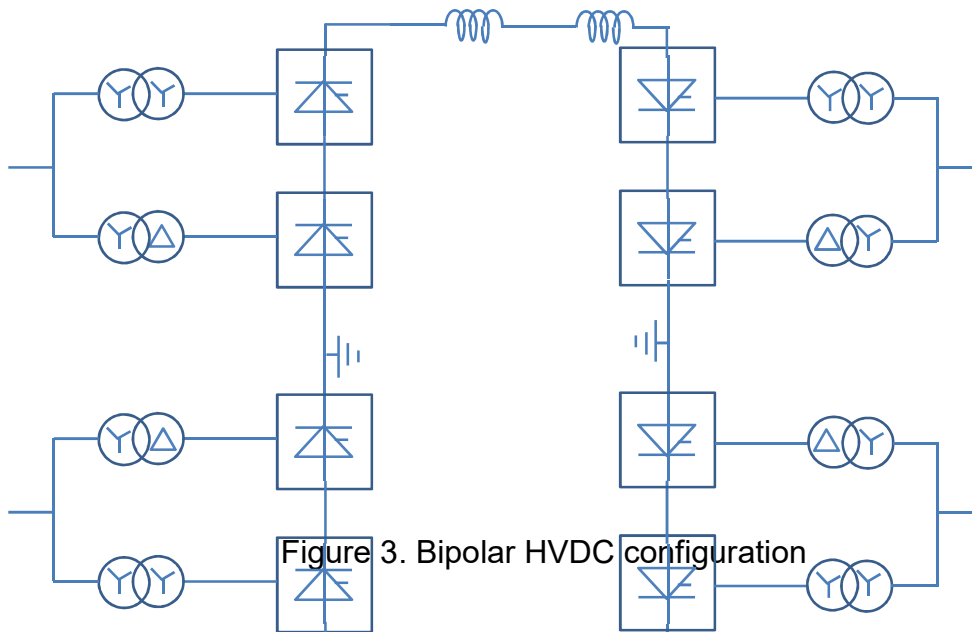

Figure 2. Monopolar HVDC arrangement with metallic return

BIPOLAR HVDC CONFIGURATIONS

A Bipolar HVDC configuration contains two poles, each of which includes one or more twelve-pulse converter units that are connected in series or parallel. Two conductors are used, one with positive and the other with negative polarity to ground for power transfer in one direction. For power transfer in the other direction, the two conductors change their polarities. A Bipole configuration is a combination of two monopolar configurations with earth path. It is presented in Figure 3. With both poles in service, the imbalance current transfer in the earth path can be kept to a very low value.



This is a typical configuration with the following operational features:

- During an outage of one pole, the other could be continuously controlled with earth return.
- For a pole outage, in case long-term earth current flow is undesirable, the bipolar configuration could be ran in monopolar metallic return mode. This is only possible if adequate DC arrangements are provided, as presented in Figure 4. Current transfer to the metallic path and back without interruption demands a Metallic Return Transfer Breaker (MRTB) and other special purpose switchgear in the terminal earth path. When a short interruption of power flow is allowed, such circuit breaker is not necessary.
- During earth electrodes or electrode lines maintenance, service is possible with connection of neutrals to the earthing grid of the terminals, with the imbalance current between the two poles kept to a very low value.

- When one pole cannot be ran with full load current, the two poles of the bipolar arrangement could be controlled with different currents, as long as both earth electrodes are connected.
- In case of partial damage to DC line insulation, one or both poles could be continuously operated at decreased voltage.

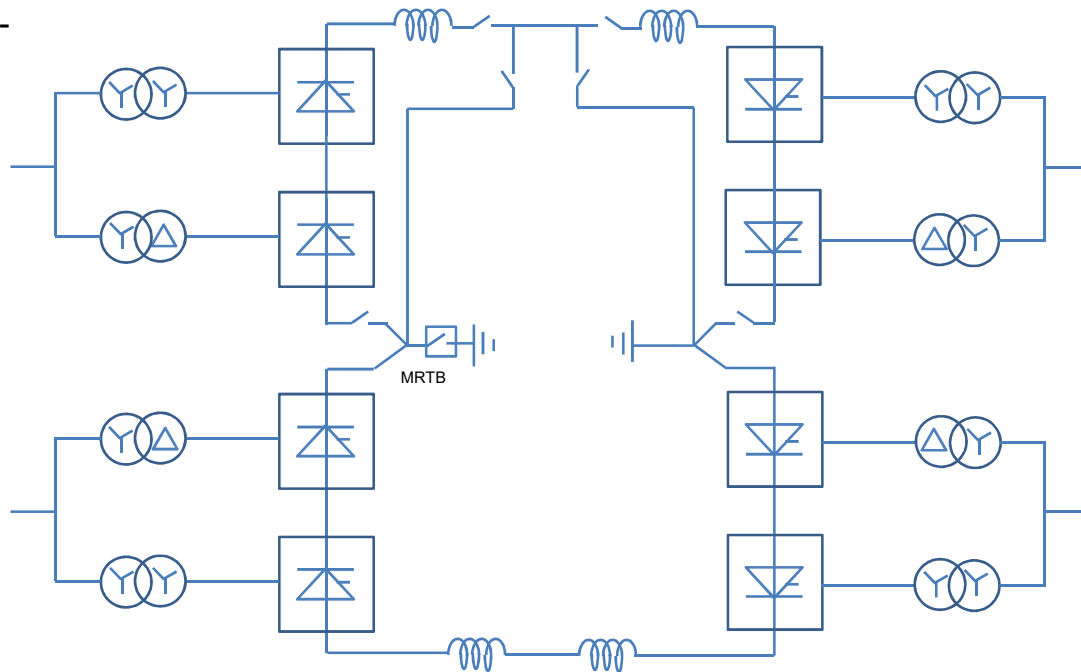

Figure 4. Bipolar configuration with monopolar metallic return for pole outage

- In place of earth return, a third conductor can be added end-to-end. This conductor transfers unbalanced currents during bipolar service and functions as the return path when a pole is out of operation.

BACK-TO-BACK HVDC CONFIGURATIONS

Back-to-back HVDC configurations are particular cases of monopolar HVDC interconnections. In these configurations, there is no DC transmission line and both converters are placed at the same site. For economic reasons each converter is typically a twelve-pulse converter unit and the valves for both converters may be placed in one valve hall. The control mechanism, cooling devices and auxiliary system may be incorporated into configurations common to the two converters. DC filters are not needed, nor are electrodes or electrode lines. The neutral connection is done within the valve hall. Back-to-back HVDC link which does not require a smoothing reactor are also

developed. They do not require external DC insulation. Figure 5 presents two different back-to-back HVDC circuit configurations. Normally, for a back-to-back HVDC link, the DC voltage rating is low and the thyristor valve current rating is high in comparison with HVDC interconnections via overhead lines or underground cables. The reason is that valve costs are voltage-dependent, as the higher the voltage the higher the number of thyristors. A low voltage tertiary winding can be installed in to the converter transformer for the AC filters and compensation. Therefore, smaller reactive power switching steps can be accomplished. Large back-to-back HVDC configurations can contain two or more independent links so that the outage of one converter unit will not cause loss of overall power capability.

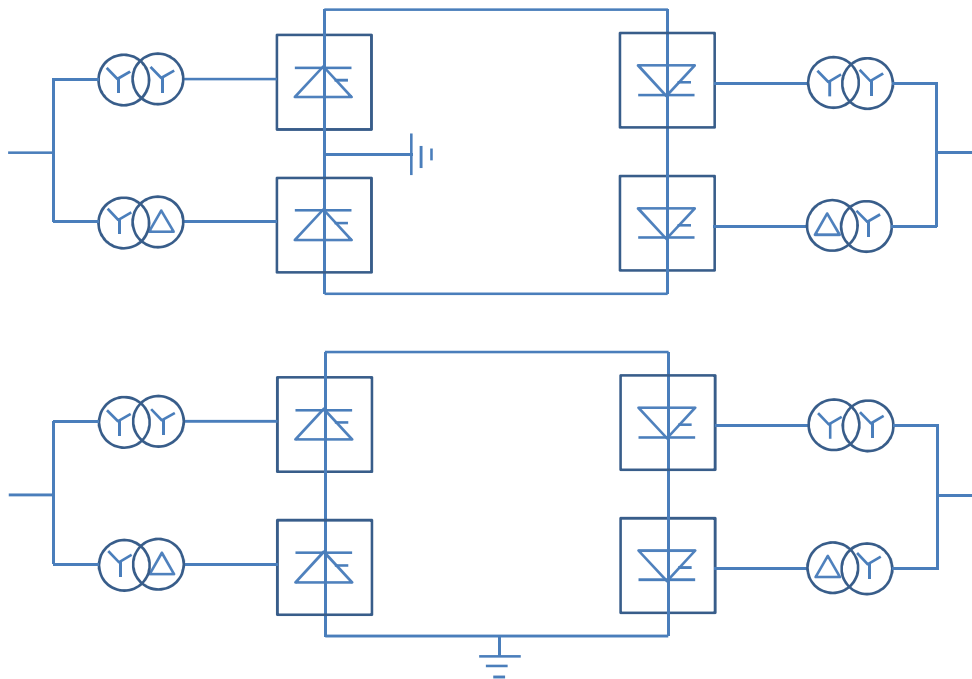

Figure 5. Back to back DC circuits

WHAT IS HVDC?

A simple HVDC interconnection scheme is presented in Figure 6. AC power is fed to a converter which works as a rectifier. Rectifier output is DC power, which is independent of the AC supply frequency and phase. The DC power is transferred through a conduction medium. It can be an overhead line, an underground cable or a short length of busbar and it is applied to the DC terminals of a second converter. The second converter is controlled as a line-commutated inverter and allows the DC power to run into the receiving AC network. Typical HVDC transmission uses line-commutated thyristor technology. Figure 7 presents a simple thyristor circuit. When a gate pulse (i_g)

is applied while positive forward voltage is imposed between the anode and cathode (V_{thy}), the thyristor will transfer current (i_L). Conduction goes on without additional gate pulses as long as current runs in the forward direction. Thyristor “turn-off” happens only when the current tries to reverse. Therefore, a thyristor converter demands an existing alternating AC voltage (V_{ac}) in order to work as an inverter. This is why the thyristor-based converter topology applied in HVDC is known as a line-commutated converter (LCC).

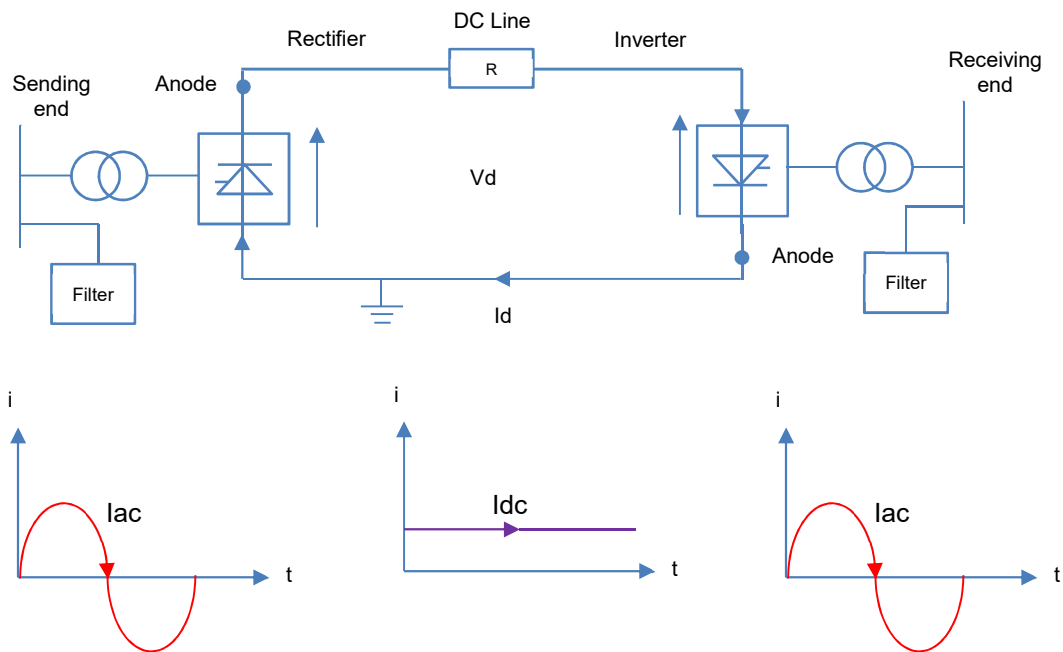

Figure 6. Essential HVDC transmission

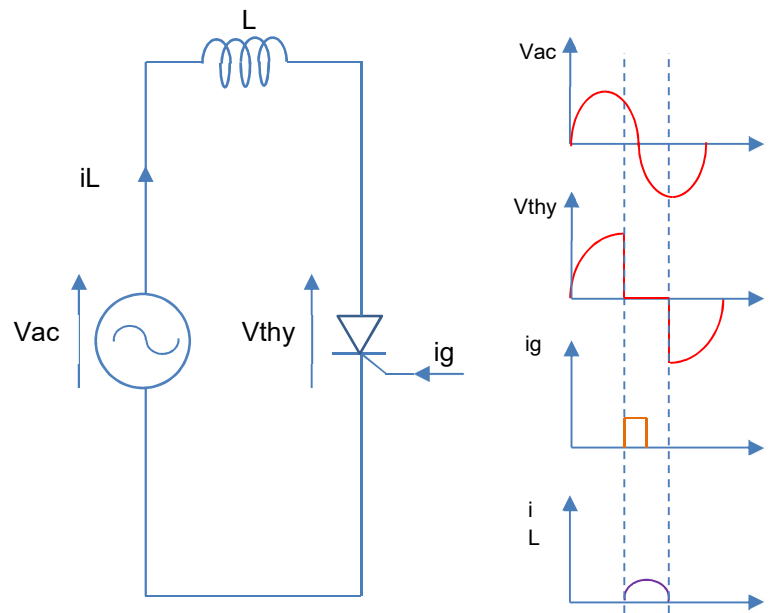

Figure 7. Thyristor gating and commutation

AC SWITCHYARD

The AC system is connected to a HVDC converter station via a “converter bus”. That is simply the AC busbar to which the converter is connected. The AC connection(s), the HVDC connection(s), connections to AC harmonic filters and other loads such as auxiliary supply transformer, extra reactive power demands, etc., can be accomplished in few ways. They are typically determined by: reliability/redundancy demands, protection and metering demands, the number of separately switchable converters and local practice in AC substation design.

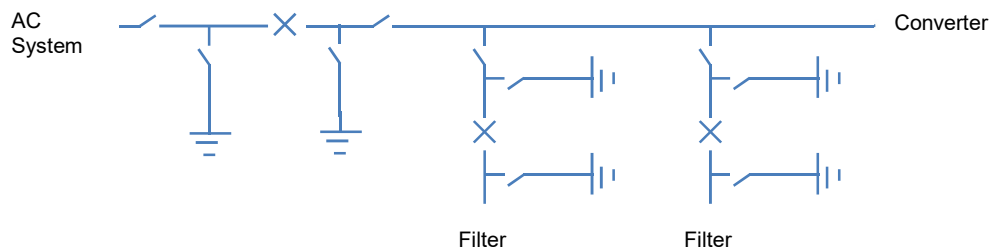

Figure 8. Single busbar

Figure 8 presents a simple, single, 3-phase busbar with one switchable connection to the AC system and the switchable AC harmonic filters which are directly connected to it. In such configuration, it is not feasible to use the AC harmonic filters for AC system reactive power support without having the converter energized. Figure 9 presents an

arrangement consisting of two converters and including an extra circuit breaker dedicated to each converter. In this configuration, the AC harmonic filters can be utilized for AC reactive power support without energising the converter. Nevertheless, in common with Figure 8, a busbar fault will end in the total converter station outage. To secure some extra redundancy a double busbar configuration can be used as presented in Figure 10. In Figure 10 an AC busbar outage will end in those loads connected to that busbar being disconnected until the disconnectors can be made to re-connect the load to the remaining, "healthy" busbar. Disconnector rearrangement will usually take roughly ten seconds and in some situations such an outage may not be acceptable. Therefore the configuration presented in Figure 11 can be applied, where each load is connected via a separate circuit breaker to each busbar. This allows quick disconnection and reconnection in the case of a busbar loss (usually around 300 ms). A weakness of the configuration presented in Figure 11 is the high number of needed AC circuit breakers. In order to decrease the number of circuit breakers, the arrangement presented in Figure 12 can be applied. In Figure 12 two loads can be separately switched between two three-phase busbars via three circuit breakers. Therefore, this configuration is typically known as a "breaker-and-a-half" configuration. Many other AC switchyard configurations exist and have been used along with existing HVDC arrangements.

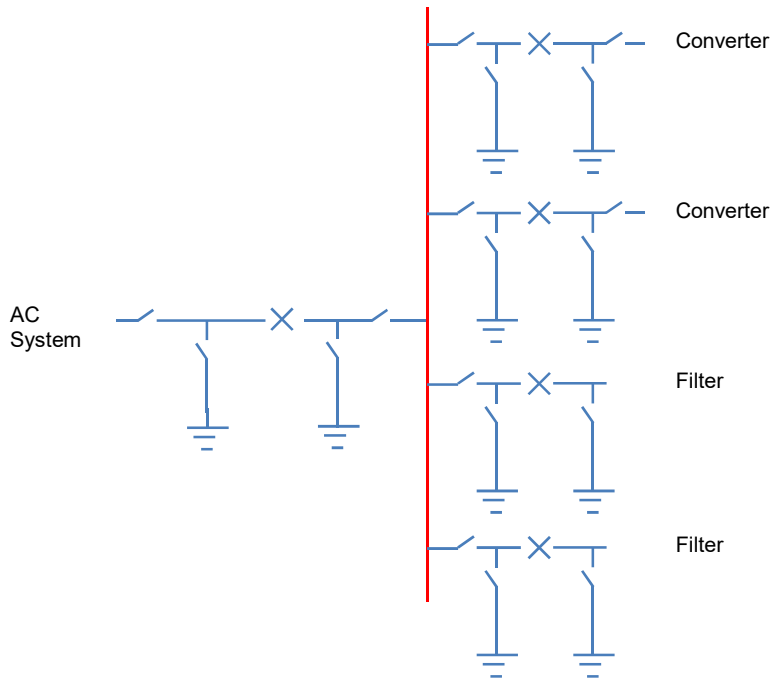

Figure 9. Single busbar with separate converter breaker configuration

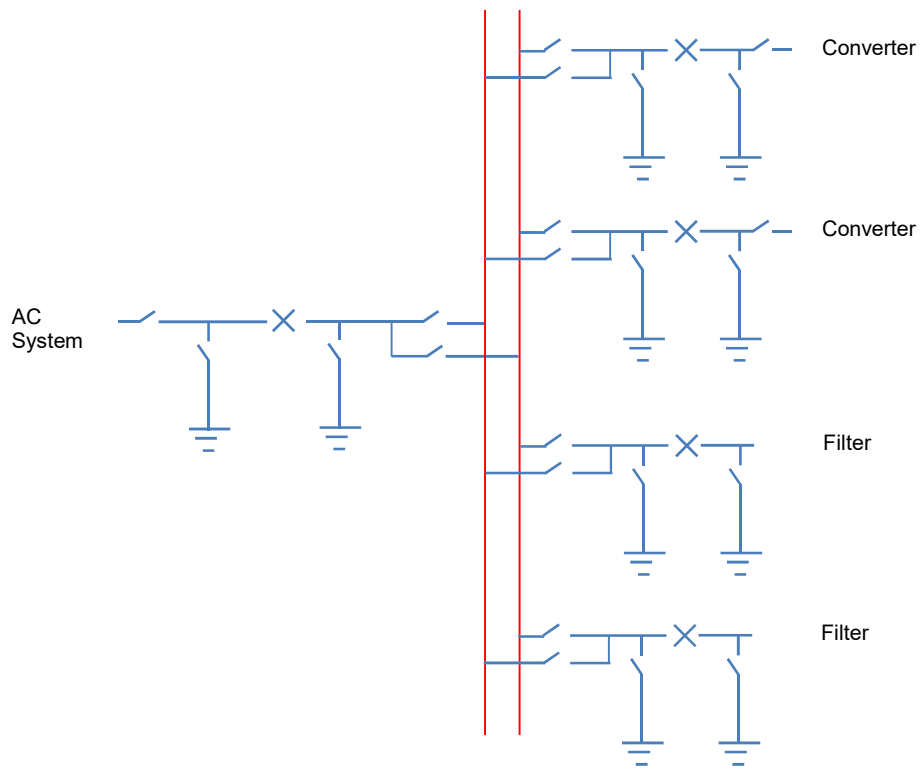

Figure 10. A double busbar configuration

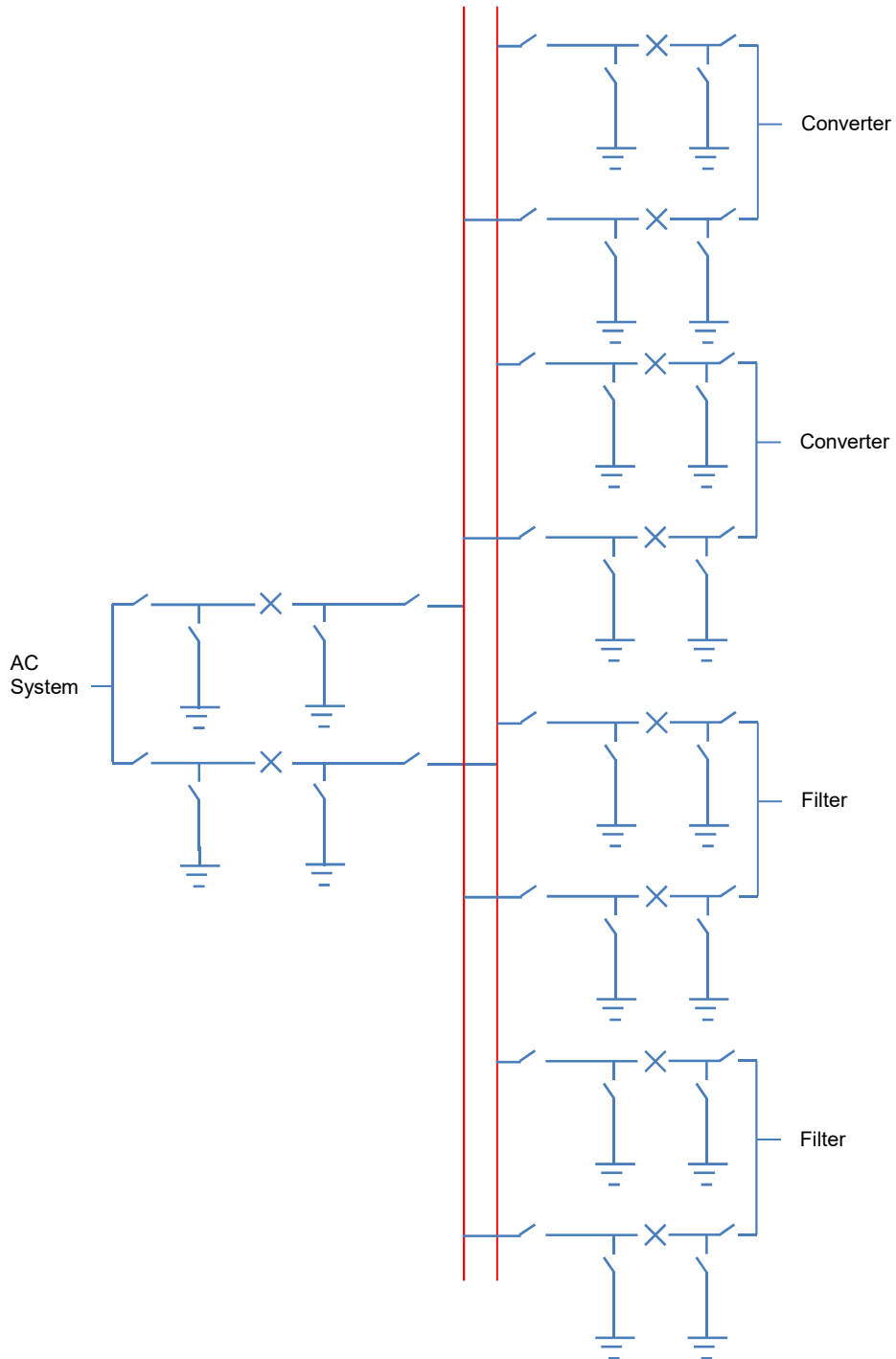

Figure 11. A double bus, double breaker configuration

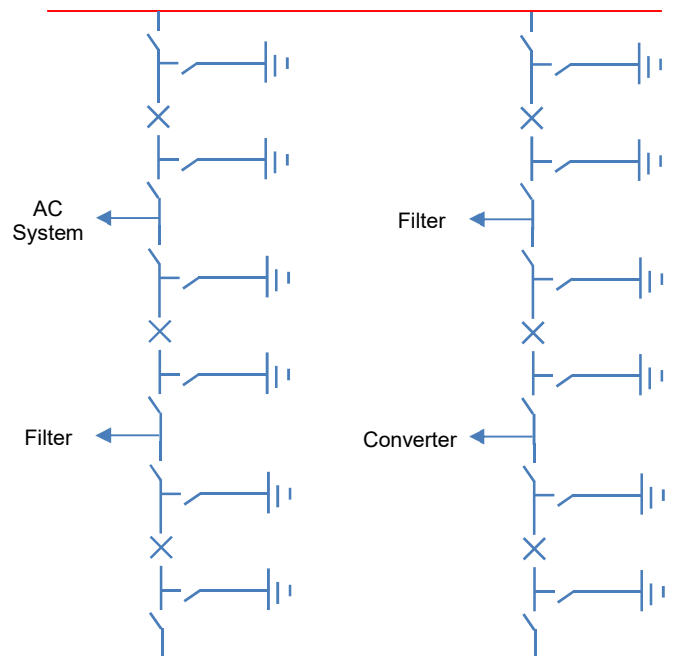

Figure 12. A breaker-and-a-half configuration

AC HARMONIC FILTERS

Converter performance results in AC current harmonics generation and the reactive power absorption. In order to fix the impact of these AC harmonic currents and the absorbed reactive power, the converter station typically includes switchable AC harmonic filters connected as shunts. They are either connected directly to the converter busbar or connected to a “filter busbar” which is connected to the converter busbar. The AC harmonic filters are automatically switched-on and off with typical AC circuit breakers when they are required to meet harmonic performance and reactive power performance limits. The AC harmonic filters are typically designed as high voltage connected capacitor bank in series with a medium voltage circuit comprising air-cored air-insulated reactors, resistors and capacitor banks. These elements are chosen to give the needed performance from the AC harmonic filter and to ensure that the filter is properly rated.

HIGH FREQUENCY HARMONIC FILTER

The converter performance will end in the generation of very high-frequency interference which will spread out into the AC system from the converter bus. While the magnitude and frequency of this interference is usually of no importance to the safe AC

system operation, there are some situations where this high-frequency interference may be unsuitable, particularly when the AC system uses Power Line Carrier (PLC) signalling.

PLC signalling is a system which transfers a communication signal as an amplitude-modulated signal, superimposed on the AC power system fundamental frequency voltage signal. This system is applied as a communication link between AC system protection devices. Nevertheless, the high frequency interference created by converter performance can overlap with the frequencies used for PLC communications (usually in the range of 40 kHz to 500 kHz). Hence, it is sometimes required to include a High Frequency (HF) filter (or PLC filter) in the connection between the converter bus and the converter in order to fix the interference that can spread into the AC system. As with the AC harmonic filter, the HF filter is made of a high voltage connected capacitor bank, an air-core air-insulated reactor and an additional low voltage circuit made of capacitors, reactors and resistors which are known as a tuning pack.

CONVERTER TRANSFORMER

The converter transformer is the link between the AC system and the thyristor valves. Normally, the HVDC converter transformer is exposed to a DC voltage insulation stress as well as the AC voltage stress that is normally experienced by a power transformer. These AC and DC stresses are different. The AC voltage stress is primarily in the insulating oil and determined by the geometry and permittivity of the materials. The DC stress is determined by the resistivity of the insulating materials which, change with operating conditions. Also, it is important that the converter transformer be thermally made to consider both the fundamental frequency load and the AC harmonic currents that will run from the converter through the converter transformer to the AC harmonic filters. Normally, the converter transformer is designed as ground star-line winding and a floating-star and delta secondary windings. Typically, there is normally an on-load tap changer on the line winding.

CONVERTER

The converter allows the transformation from AC to DC or DC to AC as needed. The fundamental building block of the converter is the six-pulse bridge. Nevertheless, majority of the HVDC converters are arranged as twelve-pulse bridges. The twelve-pulse bridge is made of 12 “valves” each of which may have many series-connected

thyristors in order to reach the DC rating of the HVDC arrangement. For a HVDC power transmission configuration, the valves associated with each twelve-pulse bridge are typically contained within a purpose built building known as a “valve hall”. For back-to-back configurations, where both the sending and receiving end of the HVDC link are installed on the same location, it is common for the valves associated with both link ends to be installed within the same valve hall.

DC SMOOTHING REACTOR

For a HVDC transmission configuration, the DC smoothing reactor gives a number of functions but essentially it is used to:

- decrease the DC current ripple on the overhead transmission line or underground cable
- decrease the maximum potential fault current that could run from the DC transmission circuit into a converter fault
- change the DC side resonances of the configuration to frequencies that are not multiples of the fundamental AC frequency
- protect the thyristor valve from fast front transients generated on the DC transmission line (e.g. a lightning strike)

The DC smoothing reactor is typically a big air-cored air-insulated reactor and is installed at the HVDC converter high voltage terminal for configurations rated at, or below, 500 kVdc. Above 500 kV, the DC smoothing reactor is typically split between the high voltage and neutral terminals.

DC FILTER

Converter services results in voltage harmonics being created at the converter DC terminals. There are sinusoidal AC harmonic components superimposed on the DC terminal voltage. This AC voltage harmonic component will end in AC harmonic current transfer in the DC circuit. Also, the field created by this AC harmonic current transfer can link with adjacent conductors, such as open-wire telecommunication systems, and create harmonic current transfer in these other circuits. In a back-to-back configuration, these harmonics are contained within the valve hall with proper shielding. With a cable arrangement the cable screen normally gives proper shielding. Nevertheless, with open-wire DC transmission it may be required to install DC filters to limit the amount of harmonic current running in the DC line. The DC filter is physically similar to an AC filter in that it is installed at the high voltage potential via a capacitor bank. Other capacitors along with reactors and resistors are then installed at the high voltage capacitor bank in order to give the desired tuning and damping.

DC SWITCHGEAR

Switchgear on the converter DC side is normally limited to disconnectors and ground switches for scheme reconfiguration and safe maintenance operation. Fault events interruption is completed by the controlled action of the converter. Therefore, it does not require switchgear with current interruption capacity. Where more than one HVDC pole share a mutual transmission conductor (normally the neutral) it is beneficial to be able to commutate the DC current between transmission paths without interrupting the DC power flow. The following DC switches can be defined.

NBGS - NEUTRAL BUS GROUND SWITCH

This switch is typically open but when closed it directly connects the converter neutral to the station ground mat. Operation with this switch can typically be kept if the converter can be ran in a bipole mode with balanced currents between the poles, that is, the DC current to ground is very small. The switch can also open, commutating a small DC unbalance current out of the switch and into the DC circuit.

NBS - NEUTRAL BUS SWITCH

A NBS is in series with the neutral connection of each pole. In the case of ground fault on one pole, that pole will be blocked. Nevertheless, the pole remaining in operation will continue to supply DC current into the fault via the mutual neutral connection. The NBS is used to divert the DC current away from the blocked pole to earth.

GRTS - GROUND RETURN TRANSFER SWITCH

The connection between the HVDC conductor and the neutral point includes both a high voltage disconnector and a GRTS and is used as part of the switching function to make the HVDC configuration as either a earth return monopole or a metallic return monopole. The disconnector is kept open if the HV conductor is energised in order to isolate the medium voltage GRTS from the high voltage. The GRTS is closed, following the disconnector closing in order to put the HV conductor in parallel with the ground path. The GRTS is also applied to commutate the load current from the HV conductor transferring the path to the ground (or ground return) path. Once current flow through the HV conductor is discovered as having stopped, the disconnector can be opened, allowing the HV conductor to be re-energised at high voltage.

MRTB - METALLIC RETURN TRANSFER BREAKER

The MRTB is used together with the GRTS to commutate the DC load current between the ground (ground return) and a parallel, otherwise idle, HV conductor (metallic return). The MRTB closes in order to put the low impedance ground return path in parallel with the metallic return path. The MRTB must also be able to open, causing current flowing through the ground return to commutate into the greater impedance metallic return path.

DC TRANSDUCERS

DC installed transducers fall into two groups, those measuring the DC voltage of the configuration and those measuring the DC current. DC voltage measurement is accomplished by either a resistive DC voltage divider or an optical voltage divider. The resistive voltage divider contains a series of connected resistors and a voltage measurement can be done across a low voltage end resistor which will be proportional to the DC voltage applied across the whole resistive divider assembly. Optical voltage transducers sense the electric field strength around a busbar with the use of Pockel cells. DC current measurement for both control and protection demands an electronic processing system. Measurement can be accomplished by generating a magnetic field within a measuring head which is adequate to cancel the magnetic field around a busbar through the measuring head. The current needed to generate the magnetic field in the measuring head is then proportional to the real current flowing through the busbar. Devices using this technique are normally known as Zero Flux Current Transducer (ZFCT). Optical current measurement uses, amongst others, the Faraday principle in which the phase of an optical signal in a fibre optic cable is impacted by the magnetic field of a busbar around which the cable is wound. By measuring the phase variation between the generated signal and the signal reflected back from the busbar, the magnitude of the current can be obtained.

STATION LAYOUT

The converter station is typically divided into two areas:

- The AC switchyard which contains the AC harmonic filters and HF filters
- The “converter island” which contains the valve hall(s), the control and services building, the converter transformers and the DC switchyard.

AC SWITCHYARD

As with any AC switchyard, the complexity and hence the needed space changes varies, dependent upon the amount of feeders and locally-switched elements that need

to be interconnected. For a HVDC converter station, the AC switchyard may be part of a major grid node. Hence, there may be a multiplicity of feeders, each with its associated towers, line end reactors, step-up/down transformers, etc. Conversely, the converter station could be placed on the network periphery and hence there may be only one or two feeders alongside the converter equipment. Nevertheless, in both situations, the space filled by these AC connections will be adequate to the AC voltage level(s).

Normally, the main HVDC converter associated components installed in the AC switchyard are the AC harmonic filters. Typically, these contain ground-level installed components placed within a fenced-off compound. Compound access is only possible once the filters have been isolated and grounded. High frequency filter elements, along with surge arresters, AC circuit breakers, disconnectors and ground switches are normally installed on structures to allow walk-around access while the equipment is energized.

CONVERTER ISLAND

In modern HVDC converter stations, the thyristor valves are normally installed indoors in a purpose built enclosure known as a valve hall. This enclosure gives a clean, controlled place in which the thyristor valves can safely function without the risk of exposure to pollution or outdoor conditions.

Within the valve hall, the thyristor valves are normally suspended from the building roof with the low voltage being closest to the roof and the high voltage being at the valve lowest point. An air gap between the valve bottom and the valve hall floor gives the high voltage insulation. The valve hall has an internal metal screen covering all walls, the roof and the floor. This screen produces a Faraday cage in order to hold the electromagnetic interference created by the thyristor valve service. The integrity of this screen is normally kept by having the valve connection side converter transformer bushings protruding into the valve hall and connecting the bushing turrets to the building screen. The DC switchyard differs widely in complexity and physical organization between projects. For outdoor DC locations, the majority of the equipment (disconnectors, ground switches, transducers, etc.) is normally installed on structures to make a walk-around area with only the DC filter. Nevertheless, where sound shielding is needed around the DC reactor, this may be ground installed with the sound shielding in the form of separate walls or an enclosure, also making the safety barrier. When the DC area is indoors, it is typical to have the majority of the equipment installed at ground level in order to avoid building excessive height requirement. In such situations, access to the DC area is controlled by a fenced-off enclosure. The control and services building

is also placed on the converter island. This building typically has equipment rooms such as:

- Control room
- Auxiliary supplies distribution
- Cooling plant room
- Workshop
- Batteries
- Offices

ACOUSTIC NOISE

Consequently, there are demands resulting from local environmental rules related to the acoustic noise any substation can produce at either its boundary or at the closest property. Much of the equipment in an HVDC converter station creates acoustic noise when working and hence careful consideration is needed in terms of equipment layout in order to decrease the acoustic noise at the measurement point.

Usual acoustic noise sources within a converter station (measured as sound power (P_{ω})) are:

- Converter transformer (105 dB(A) sound power)
- DC smoothing reactor (110 dB(A) sound power)
- AC harmonic filter reactor (100 dB(A) sound power)
- Valve cooling (air blast coolers) (100 dB(A) sound power)
- AC harmonic filter capacitors (80 dB(A) sound power)
- Transformer cooling (105 dB(A) sound power)

As an approximation, the acoustic noise sound pressure ($L_{\omega}(A)$) from any individual point source, at a distance ' χ ' from the component is computed as follows:

$$L_{\omega}(\chi) = P_{\omega} - 20x \log_{10} \chi - 8$$

Where:

$L_{\omega}(\chi)$ – the sound pressure at a distance χ (in meters)

P_{ω} – the acoustic sound power of the point source (dB(A))

χ – the distance from the point source at which the sound pressure is to be computed (in meters)

In order to reach the boundary, or nearest residence, acoustic noise limit, it may be required to install acoustic noise barriers or to modify the equipment. The barriers may be walls or enclosures.

SIX-PULSE DIODE CONVERTER BRIDGE

Six-pulse converters are essential block of HVDC systems. An example of a six-pulse converter, which uses diodes, is presented in Figure 13. Diodes conduct in the sequence 1,2,3,4,5,6, so the transitions between one diode and the next happen alternately in the upper and lower half-bridges. Each diode conducts for 120° , in every 360° cycle, so that the consecutive conducting pairs of diodes are 1 and 2, 2 and 3, 3 and 4, 4 and 5, 5 and 6, and 6 and 1. The conducting pair is always diodes pair which have the highest instantaneous AC voltage between them. The other diode pairs are connected to an instantaneously smaller voltage and therefore are exposed to a reverse voltage across their terminals. As time goes, the relative amplitudes of the converter's three AC supply phases (valve-winding voltages) change, so in Figure 14 the voltage B-C becomes higher than the voltage A-C and valve 3 takes over the current which had been running in valve 1. This process is known as "commutation". In this idealisation, the mean direct voltage, V_d , emerges as a constant value, completely fixed by the transformer ratio, the calculation of which is presented in Figure 15. This value is known as the "No-Load DC Voltage", or V_{dio} , of the converter.

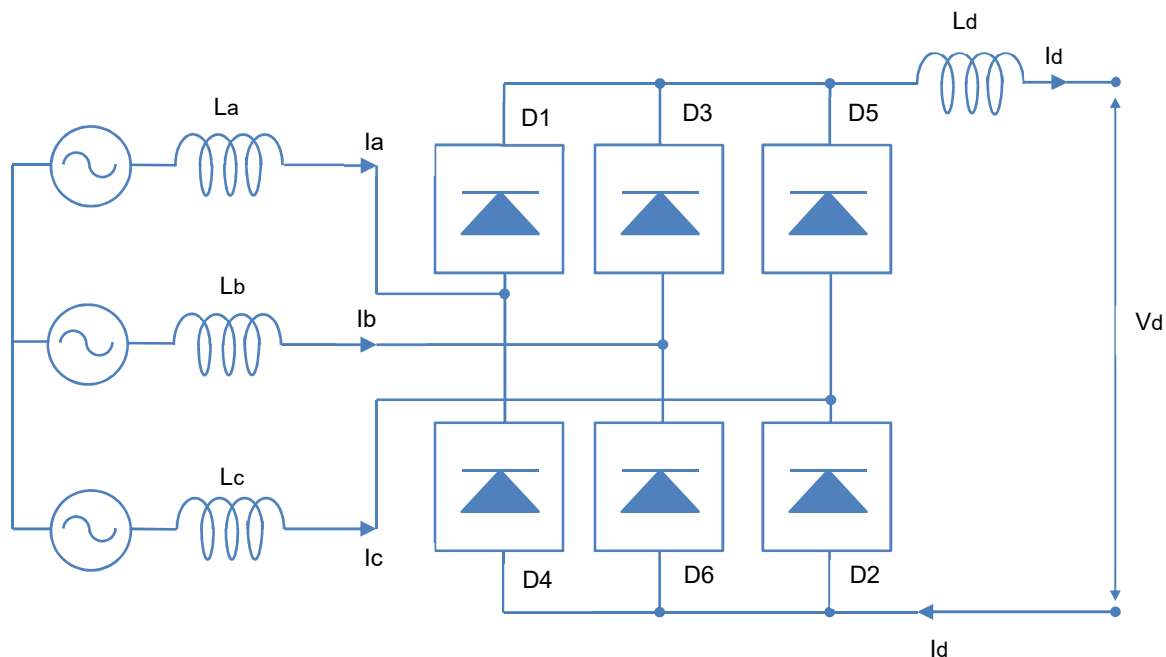

Figure 13. Six-pulse converter bridge configuration

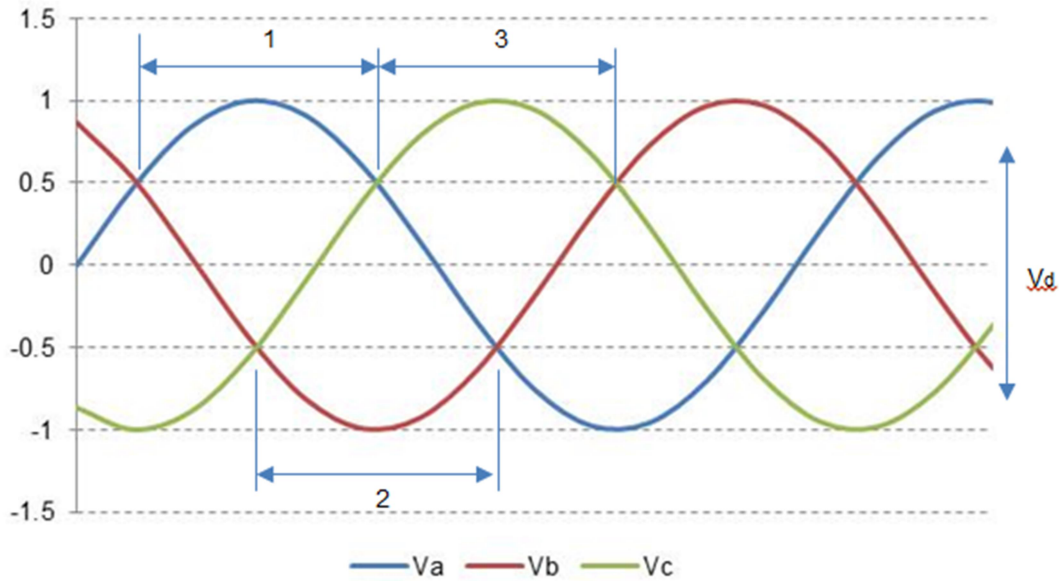

Figure 14. Current switching pattern of a six-pulse converter

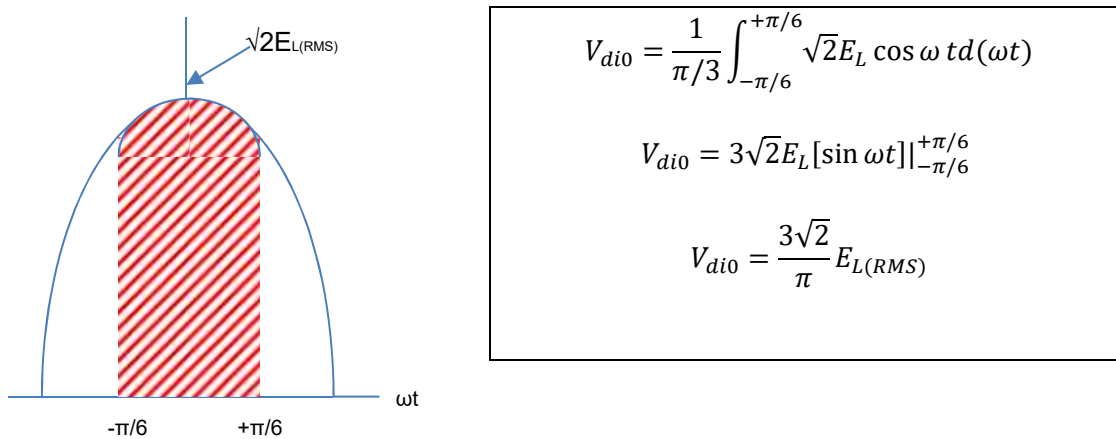

Figure 15. The no-load DC voltage of a six-pulse bridge

COMMUTATION

In reality, the current transfer from one diode to the next needs a finite time, since the current transfer is slowed down by the commutation reactance (consisting of converter transformer reactance, the thyristor valve and a small amount in the HF filtering circuit). This creates an "overlap" between successive conduction periods in one-half of the six-

pulse bridge. Figure 16 presents that the mean direct voltage (V_d) has been decreased in comparison to Figure 14. Figure 16 also presents the valve current waveform during the commutation process, where current falls in one valve, while the current increases in the next valve in sequence. The time needed to commutate the current from one valve to the next is known as the “overlap angle”, μ .

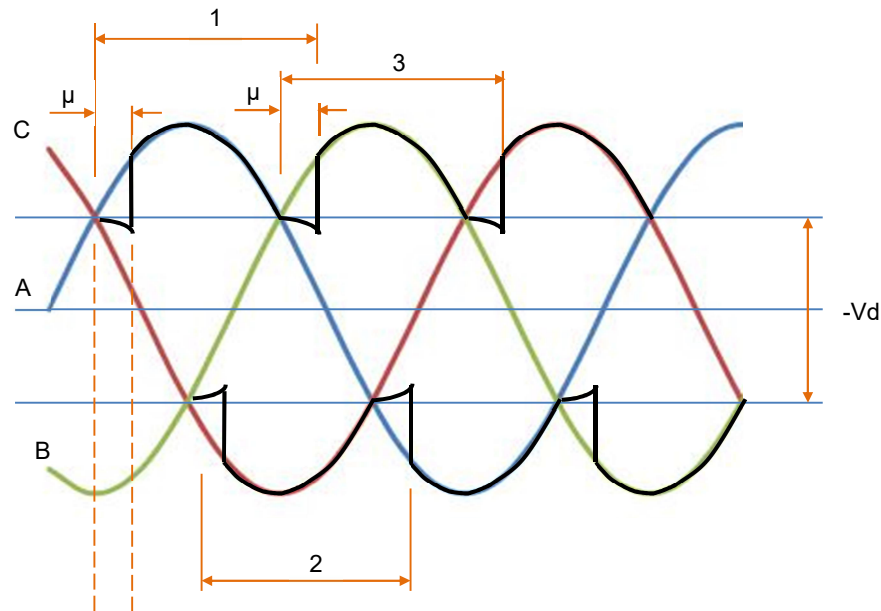

Figure 16. Commutation effect on converter operation

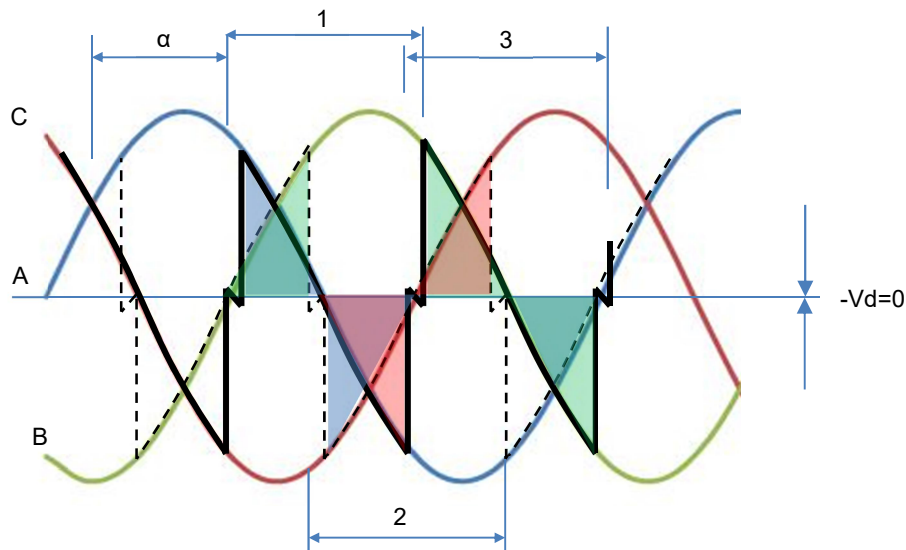

Figure 17. Effect of firing angle as it approaches 90°

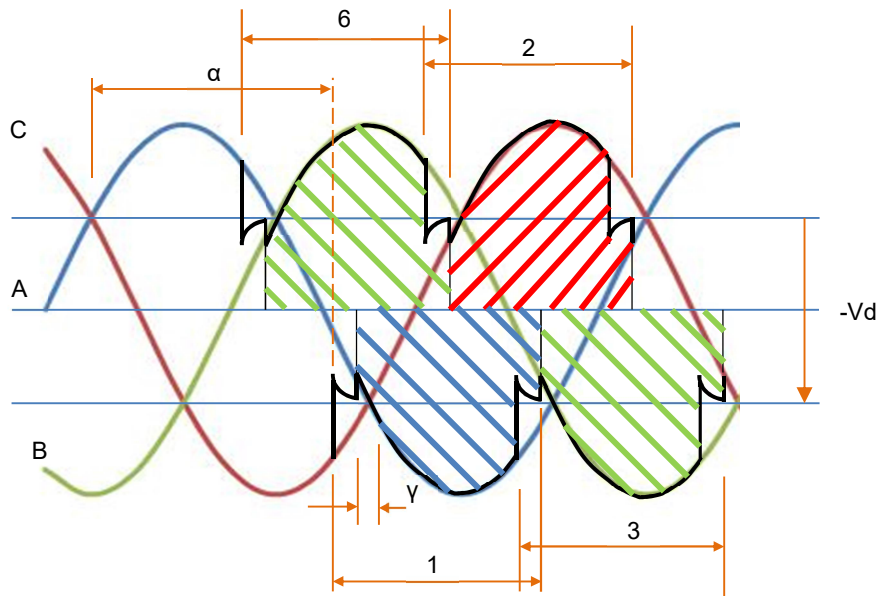

Figure 18. Effect of a firing angle of 140°

THYRISTOR CONTROLLED CONVERTER

In a thyristor converter, presented in Figure 19, it is possible to change the mean direct voltage by controlling the instant at which the thyristors are switched on. A thyristor is turned on by using a short pulse to its gate terminal and turns off when the external circuit forces its anode current to zero. In this situation, current zero is brought about by the commutation process when the next thyristor is fired. The firing delay angle α is defined as the angle between the phase voltage crossing of the valve-winding voltage and the instant when the thyristor is fired. This is presented in Figure 20. This delay angle influences when the commutation process will start and consequently sets the mean direct voltage (V_d). V_d is directly proportional to the cosine of α . For example, the bigger the delay angle, the smaller the mean direct voltage. Zero voltage is reached as α reaches 90° .

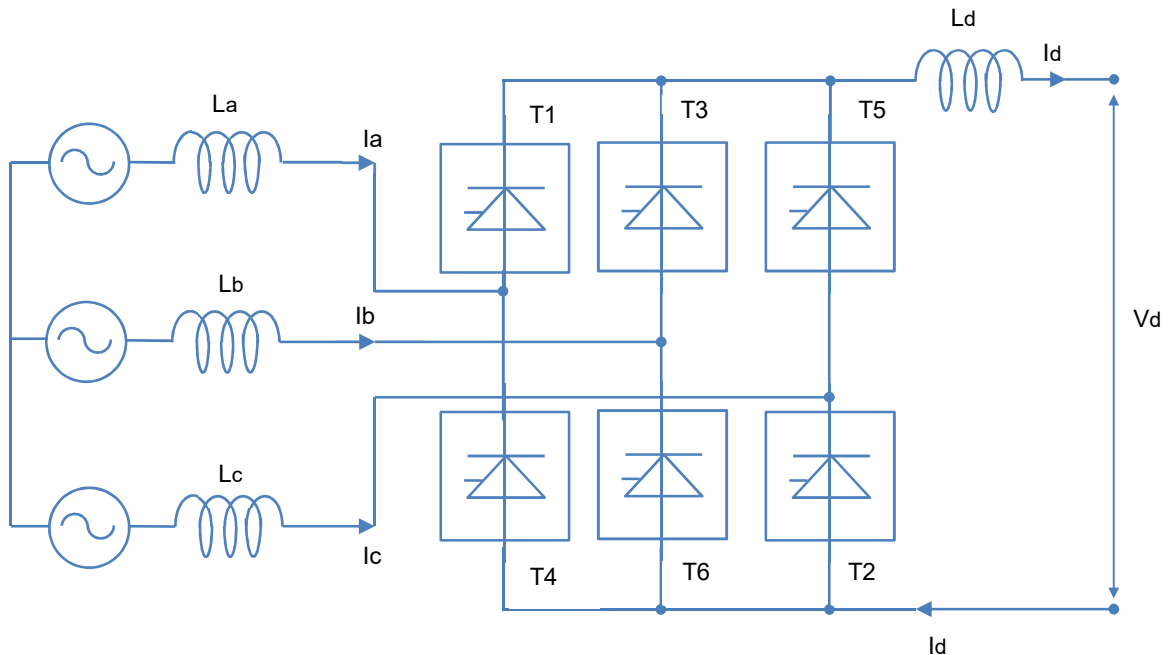

Figure 19. Thyristor converter configuration

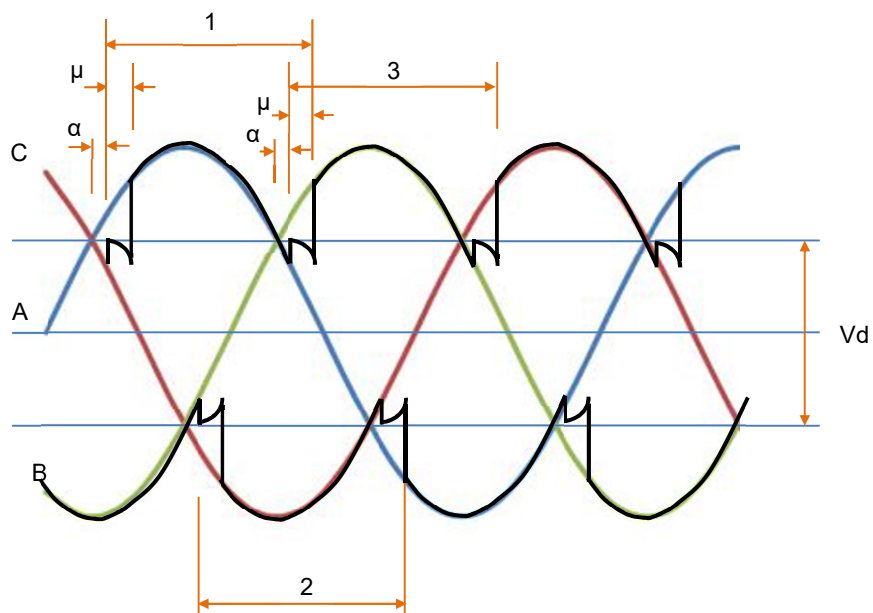

Figure 20. Effect of firing angle on converter function

THE INVERSION PROCESS

By increasing the firing angle, α , above 90° , the voltage area of the line-to-line voltage connected to the DC terminals via the conducting thyristors will be mainly negative.

Therefore, the DC terminal voltage will be negative. Since, above 90° , the converter firing angle becomes big, it is more common to refer to the “extinction angle” or “gamma”, γ . This extinction angle shows the time between the end of the overlap period and the time when the phase voltage related with the outgoing valve becomes more positive/negative than that of the next valve in sequence. This is calculated as:

$$\gamma = 180^\circ - \mu - \alpha$$

It must be taken into account that the control of the output voltage of a six-pulse bridge is accomplished by the firing angle, α . The extinction angle, γ , is a representation of the available valve turn-off time following the point in time where the valve is fired.

VALVE VOLTAGE WAVEFORM

Common voltage waveforms across a valve during rectification and inversion are presented in Figure 21 and Figure 22, respectively. The “notches” in the waveforms are created when commutation starts, because commutation is a temporary phase-to-phase short circuit, created by the converter valves. This does not increase to heavy fault currents. Nevertheless at the instant the current in the valve which has just fired becomes same as the main direct current, the valve which is relinquishing current turns off, breaking the circulating current path.

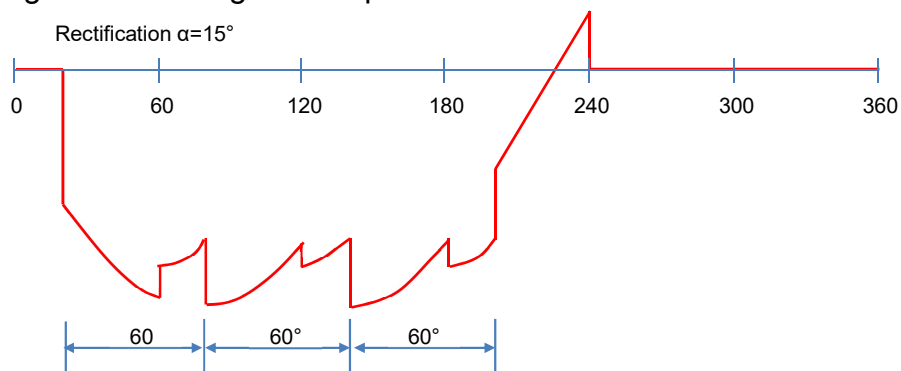

Figure 21. Rectifier valve voltage waveform (excluding commutation overshoots)

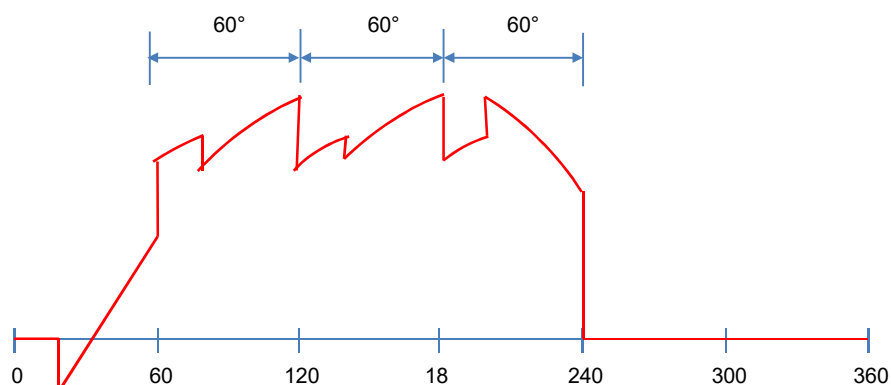

Figure 22. Inverter valve voltage waveform (excluding commutation overshoots)

TWELVE-PULSE BRIDGE RECTIFIER

Because of the high power levels related with HVDC transmission, it is important to decrease the current harmonics produced on the AC side and the voltage ripple generated on the converter DC side. This is accomplished by means of connecting two six-pulse bridge circuits in series on the DC side/parallel on the AC side to create the twelve pulse bridge arrangement (Figure 23.) Each of the bridges in Figure 23 is linked to the AC network by a single-phase three-winding transformer. One of the transformers is Y/Y (star/star) connected and the other Y/ Δ (star/delta). The Δ is on the DC side. Through this connection the bridges have a phase difference of 30° in supplying AC power. Mechanically the valves can be organized in three parallel stacks containing four valves linked in series.

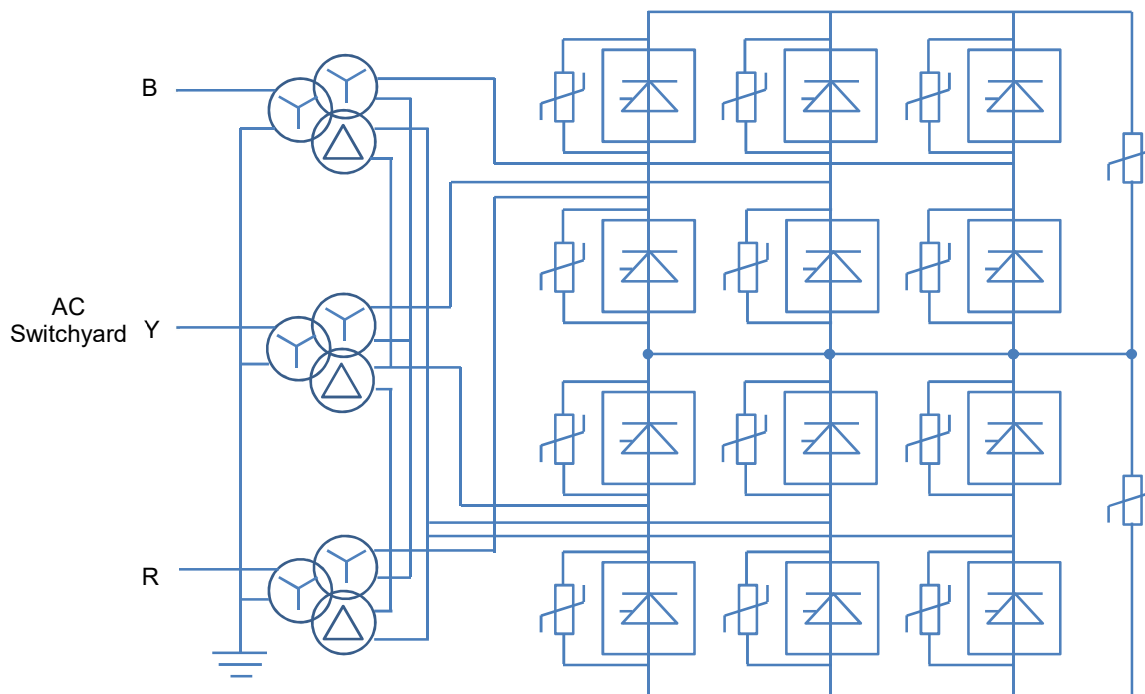

Figure 23. Twelve –pulse converter configuration

HVDC LINK CONTROL

Consider Figure 24, the voltage across the rectifier is positive with respect to both its anode terminal as well as the ground reference. Nevertheless, the inverter terminal is producing a negative voltage with respect to its anode terminal. Since it is connected in reverse parallel to the rectifier, its voltage with respect to the ground reference is also positive. Since the rectifier voltage and the inverter voltage are independently controlled, they can have different values. Therefore, there will be a voltage difference across the resistor in the DC circuit which, as long as the rectifier voltage is higher than the inverter voltage, will cause a DC current to flow. This can be presented as:

$$I_d = \frac{V_{rectifier} - V_{inverter}}{R_d}$$

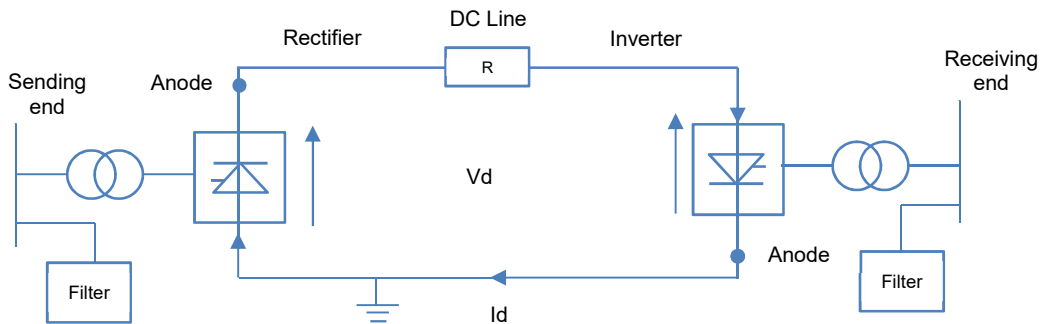

Figure 24. Inverter control arrangement

Under normal, steady-state service, the inverter control arrangement is typically organized to keep the DC voltage at a certain point on the HVDC link (known as the “compounding point”) at a set value. This target value is commonly 1.0 pu for a transmission network but for back-to-back arrangements, where the DC transmission losses can be neglected, this value can be varied to give an additional degree of reactive power control. The “compounding point” is typically at the rectifier DC terminal. Therefore, the inverter must compute this voltage based on the DC voltage at the inverter terminals, the DC current and the transmission circuit known resistance. The rectifier typically controls the DC current running in the circuit and completes this by adjusting DC voltage output to give a current flow as expressed by the above equation. There are several ways that a six-pulse converter can be controlled in a HVDC link.

For a rectifier the control possibilities are:

- Constant valve winding voltage control – With this control method, the converter transformer tap changer is used to keep the voltage applied to the AC terminals of each six-pulse bridge to a constant target value. Current control is then accomplished by change in converter operating angle.
- Constant firing angle range control – With constant valve winding voltage control, the firing angle at lower power transmission levels can be high. To decrease the range over which the firing angle can function in the steady state, the converter transformer tap changer can be applied to change the used AC voltage to the six-pulse bridge. Therefore, it can limit the range over which the firing angle works.

For an inverter the control possibilities are:

- Fixed valve winding voltage control – This is the same as the equivalent rectifier control.
- Fixed gamma angle range control – This is similar to the rectifier “fixed firing angle range control” but reacts on the inverter extinction angle instead of the firing angle.
- Fixed extinction angle control (CEA) – With this control method, the inverter DC voltage is allowed to change in order to reach a constant extinction angle with changing DC current. The inverter converter transformer tap changer is used to adapt the used AC terminal voltage in order to keep the DC voltage to within a constant, steady-state, range.

STATIC CHARACTERISTICS

The static characteristics can be conceived as the cerebral cortex of the converter. The static characteristics determine the way in which the converter reacts to transients without involving higher control functions. The six-pulse bridge can be simplified to a battery in series with a resistor as presented in Figure 25.

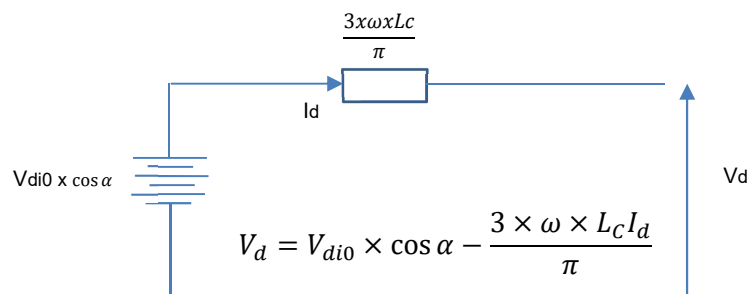

Figure 25. A basic six-pulse converter configuration

It is important to note that the resistor presented in Figure 25 is not a real resistor but is simply put in the above circuit to simulate the voltage regulation effect of the impedance of the converter bridge connection. This resistor does not have any I^2R losses. Consider the circuit presented in Figure 25. As the DC current through the converter goes to 1.0 pu, the voltage drop across the “resistor” increases, decreasing the DC terminal voltage at the circuit, as presented in Figure 26. Once at 1.0 pu DC current, the voltage can then be changed by increasing the firing angle. At a firing angle of 90° , the DC voltage is zero but the DC current, if supplied from a separate source, remains at 1.0 pu. When

in inverter mode, the converter will allow a DC current to run through it is supplied by a separate DC current source. As the firing angle rises (extinction angle decreases), the converter DC terminal voltage rises up to the minimum extinction angle at which point the DC current must be decreased to accomplish additional DC terminal voltage increases, following a constant extinction angle line.

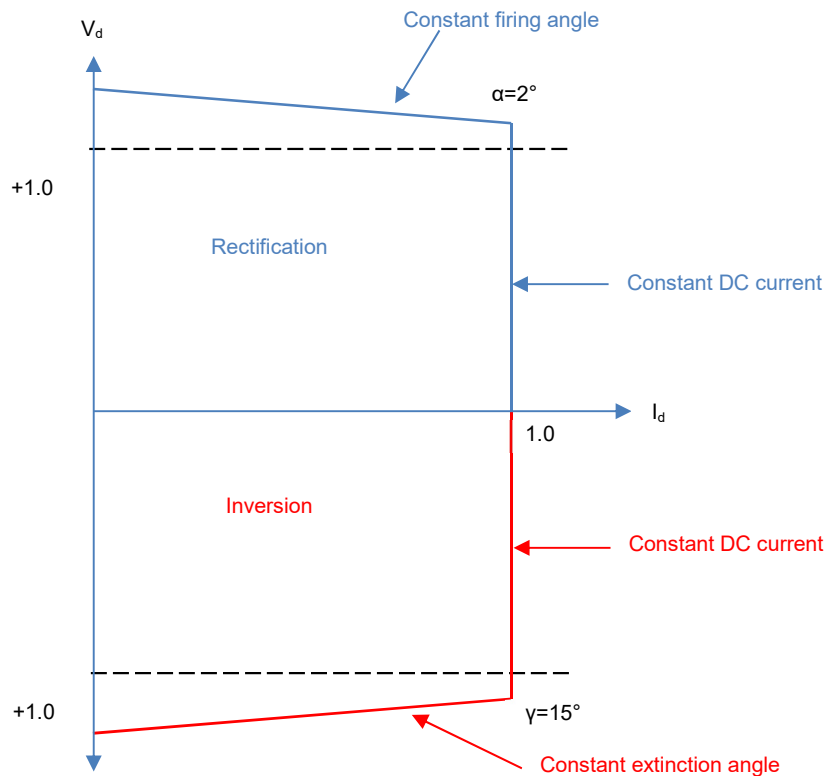

Figure 26. Converter operating profile

By vertically flipping the inverter characteristic and printing it on the same graph as the rectifier characteristic, the operating point, which is the point where the rectifier characteristic and the inverter characteristic cross, is found. This is presented in Figure 27.

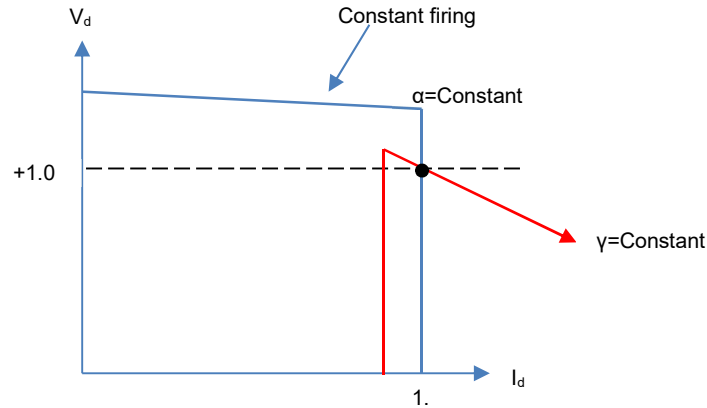

Figure 27. The basic static characteristic of an HVDC configuration

Nevertheless, with these static characteristics, as shown in Figure 28, if the AC voltage applied to the rectifier decreases then there are more crossover points between the rectifier and the inverter. Therefore, the operating point cannot be set. To resolve this, the basic converter characteristics are changed in order to control the way that the converters reacts during transient events.

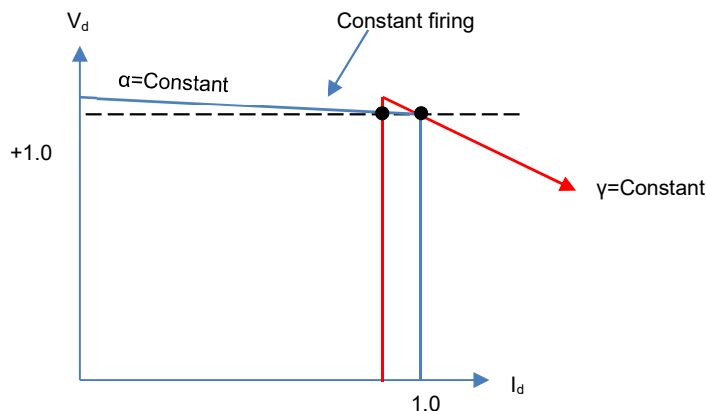

Figure 28. The basic static characteristic of an HVDC configuration with decreased rectifier AC terminal voltage

An example of a real characteristic is presented in Figure 29. Note that in Figure 29 the inverter constant current characteristic is at a lower DC current than the rectifier constant current characteristic. Under normal service, the inverter controls the DC voltage and the rectifier controls the DC current. Nevertheless, if the AC terminal voltage at the rectifier decreases such that the rectifier characteristic presented in Figure 29 crosses the inverter constant current characteristic, then the inverter will keep the DC current at this level with the DC voltage being determined by where the rectifier characteristic crosses the inverter constant current characteristic.

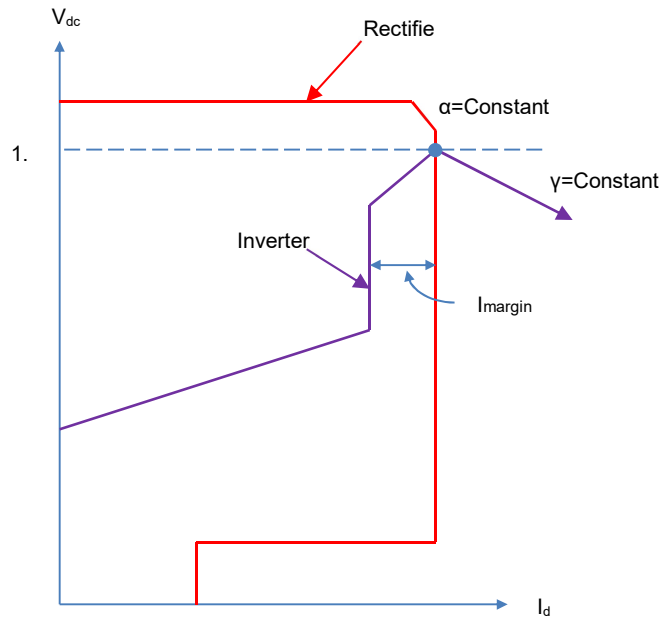

Figure 29. A real HVDC link static characteristic

The margin between the rectifier constant current characteristic and the inverter constant current characteristic is known as the “current margin”. Some dynamic characteristics can be laid over the static characteristic as presented in Figure 30. For instance, a constant real power curve can be superimposed showing the needed DC current for a given DC voltage variation to keep the rectifier DC terminal power. Another characteristic that can be laid over is one of constant reactive power. If the operating point were to be kept along the reactive power curve, then at any point the reactive power taken by the converter would remain fixed. Therefore, if there is a decrease in, for instance, the rectifier AC system, then, by following roughly constant reactive power curve, the variation in reactive power at the inverter terminal is minimized, although there is a variation in real power. Therefore, the converter bus voltage at the inverter would stay roughly constant.

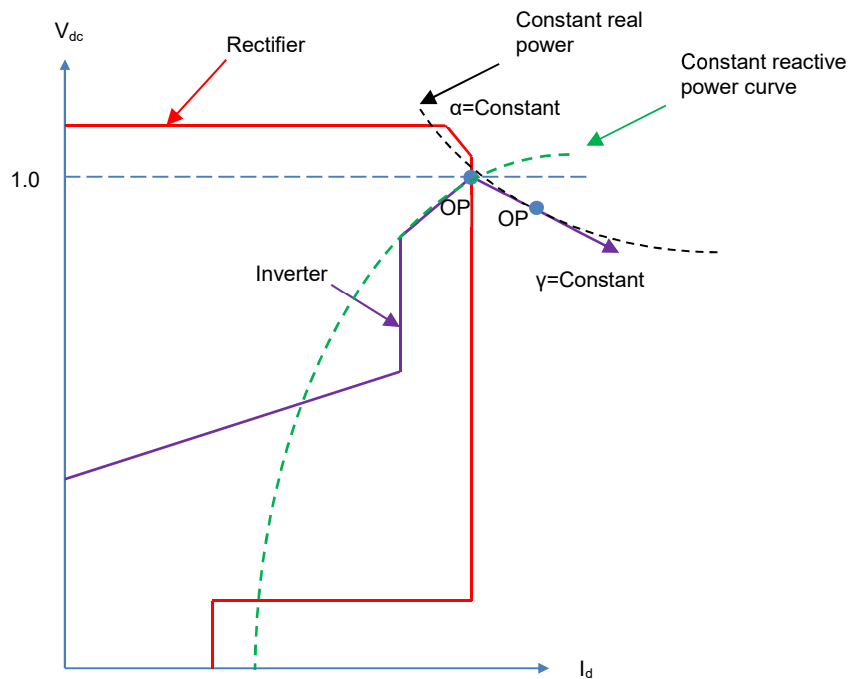

Figure 30. Constant real and reactive power characteristics laid over on the static characteristics

REACTIVE POWER IN AC SYSTEMS

Reactive power is integral part of all AC power systems. It is a quantity that is caused by the stray capacitance and inductance within all power system elements. It shifts, in phase, the current AC waveform with respect to the voltage AC waveform. Therefore, it reduces the instantaneous value of voltage multiplied by current. In order to evaluate phase shift effect, the AC power is considered as two components. The “Real” power, that is determined by in-phase voltage component and current. The “Reactive” power, that is determined by the out of-phase component of voltage and current. Reactive power can be leading in which case the current waveform is phase advanced with respect to the voltage waveform. Reactive power can also be lagging in which case the current waveform is phase delayed with respect to the voltage waveform. In HVDC configurations, it is conventional to consider leading reactive power as a “source” or “generator” of reactive power and lagging reactive power as a “load” or “absorber” reactive power. Therefore, reactive power resulting from capacitance is created and reactive power resulting from inductance and from the converter is absorbed.

An AC network is comprised of generators, VAr compensators, transmission lines and different inductive and capacitive loads. Reactive power transfer through the AC system ends in voltage change between busbars. When any extra reactive power source or

load is connected to a busbar within the AC system, the change in voltage at both that busbar and interconnected busbars should still be kept within the steady-state limits. Hence, there is always a reactive power limit that can be connected to a busbar.

THE REACTIVE POWER CONVERTER LOAD

Converters are a reactive power load since they work with a delay firing angle which leads to a situation where the current lags the voltage. In addition, the converter transformer impedance (plus the small valve impedance) creates an additional current lag which is observed as the overlap angle. The converter operating overlap angle is a function of the operating current and the converter transformer leakage reactance:

$$\mu = \cos^{-1} \left[\cos(\delta) - \frac{I_d}{I_{d0}} x \chi_p \right] - \delta$$

- μ - the converter overlap angle (rad)
- I_d - converter DC operating current (pu)
- I_{d0} - rated converter DC operating current (pu)
- χ_p - converter transformer leakage reactance (pu)
- δ - converter control angle (α for rectifier operation, γ for inverter operation)

From the overlap angle and the converter firing angle, the converter operating power factor can be roughly computed as follows:

$$\cos \phi = \frac{1}{2} X [\cos(\delta) + \cos(\delta + \mu)]$$

Therefore, the reactive power absorption is roughly:

$$Q_{dc} = \tan[\cos^{-1}(\phi)] \times P_{dc}$$

Where:

- Q_{dc} - the converter reactive power absorption (pu)
- $\cos \phi$ - the converter power factor ($^{\circ}$)
- P_{dc} - the converter station real power (pu)

The converter reactive power absorption at rated load can be roughly calculated as follows:

$$Q_{dc0} = \tan \left[\cos^{-1} \left(\cos \delta - \frac{\chi_p}{2} \right) \right]$$

Where:

Q_{dc0} – the converter reactive power absorption at rated DC current (pu).

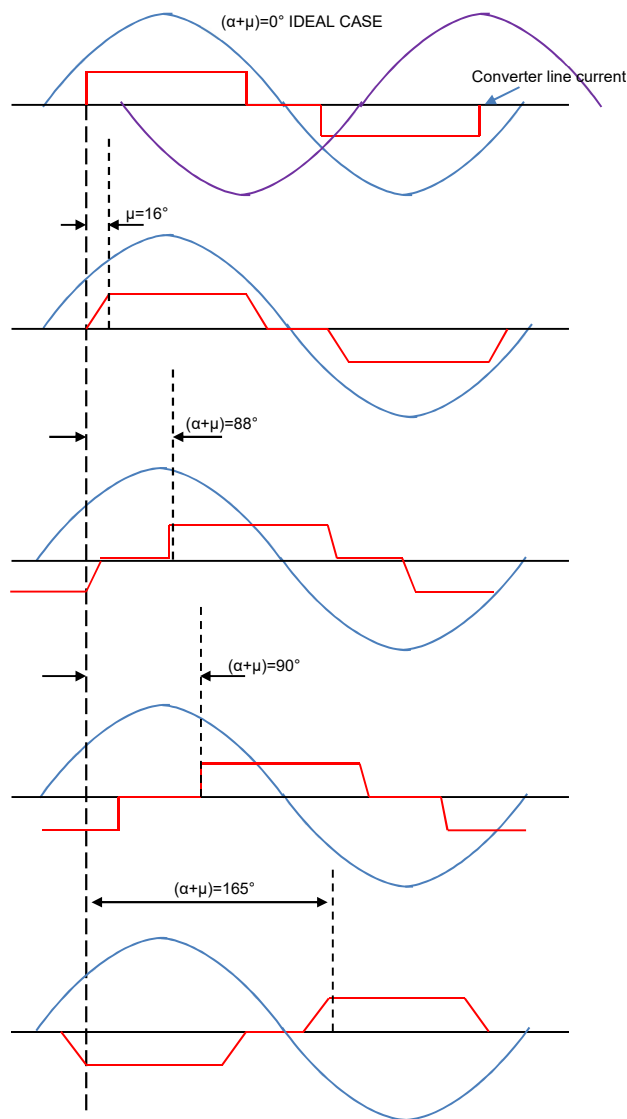

Figure 31. Lagging currents in rectifier and an inverter

REACTIVE POWER SOURCES WITHIN A CONVERTER STATION

The major sources of capacitive (positive) reactive power in a HVDC station are the AC harmonic filters. Harmonic filters have two applications: decreasing the harmonics injected into the AC system and creating reactive power. An AC filter is comprised of

capacitances, inductances and resistances but at fundamental frequency the HV-installed capacitor is the main contributor to the generated reactive power.

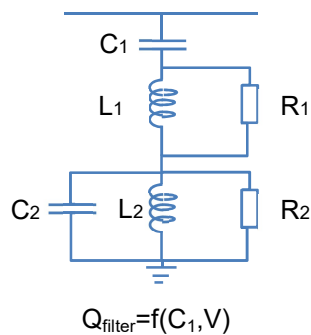

Figure 32. Typical AC harmonic filter scheme

CONTROLLING CONVERTER REACTIVE POWER

In order to meet the AC harmonic performance, each filter needs to be switched in at a certain DC power transmission level. This is known as “open-loop” control, as presented in Figure 33. These points are found from AC harmonic studies. Converter control action can be used to change the reactive power exchange with the AC system. In a HVDC arrangement, the DC power is expressed as:

$$\text{DC Power} = \text{DC Voltage} \times \text{DC Current}$$

Therefore, for a given DC power level the voltage can be decreased and the current proportionately increased at the expense of additional I^2R transmission losses. Hence, if the number of energized filters needed to meet AC harmonic filter performance exceeds the reactive power exchange limits, the converter operating conditions can be modified to increase the reactive power absorbed by the converter. This is done to accomplish the required exchange target between the converter station and the AC system. The variation in DC conditions is accomplished by decreasing the DC voltage which needs the firing delay angle to be increased and with an increase in DC current, to keep the DC power constant, the overlap angle rises. Therefore the reactive power absorbed by the converter increases. It has to be kept in mind that as the DC side of the converter is common to the rectifier and inverter, changing the DC conditions will decrease, or increase, the reactive power load at both rectifier and inverter together. Figure 34 presents a common operating range for the DC voltage on a back-to-back HVDC converter. In Figure 34 the upper limit is determined by the minimum allowable converter operating angles while the lower limit is determined by the maximum voltage

transient that can be applied to the converter resulting from the rectifier firing voltage or inverter recovery voltage.

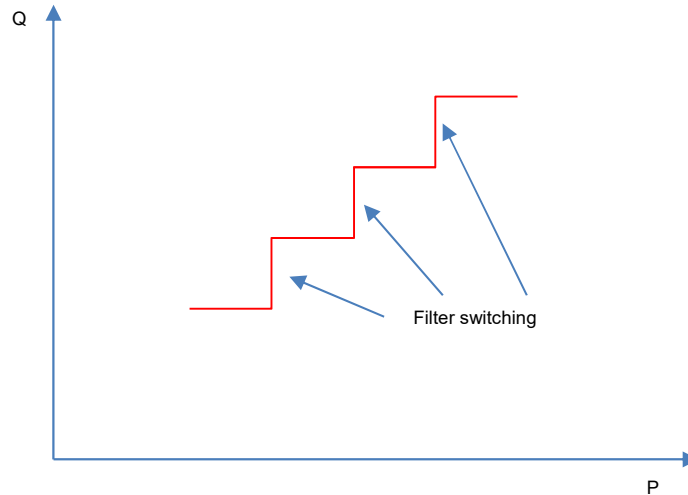

Figure 33. Filters switched with changing DC power

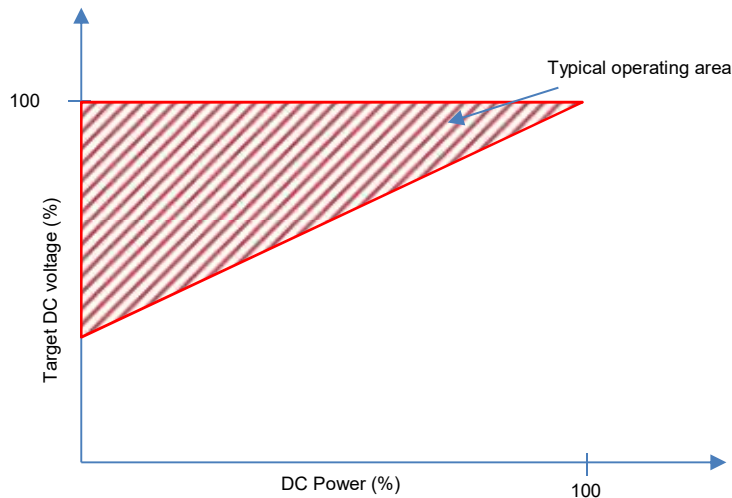

Figure 34. Common operating range of DC voltage on a back-to-back configuration

VOLTAGE STEP VARIATIONS

Another demand imposed on reactive power control is that of not surpassing a predetermined AC voltage step change as a consequence of switching a filter bank (or any reactive power element). As an estimate, the voltage step change magnitude, as a consequence of switching a filter, can be calculated from:

$$\Delta V = \frac{Q_{SWITCH}}{SCL_{min} - Q_{TOTAL}}$$

Were:

ΔV – the change in AC voltage (pu)

SCL_{min} – the minimum AC system short circuit level in which the switching operation is to take place (MVA)

Q_{SWITCH} – the reactive power step to be imposed on the AC system (MVAR)

Q_{TOTAL} – the total reactive power connected to the converter bus including the reactive power to be switched (MVAR)

Where the step change in AC voltage surpasses a predetermined limit, it is possible to increase the effective limit by imposing an opposite change in reactive power at the converter busbar. This opposite change can be accomplished through converter action by using a fast change to the DC voltage. As an example, consider switching in a filter onto an AC system that has a fundamental frequency var rating, which would surpass the AC voltage step change limit. By increasing the DC converter absorption at the same instant as the filter bank circuit breaker closes, the net reactive power exchanged with the AC system can be controlled and therefore AC voltage step change.