



Fluid Flow

Course Number: ME-02-104

PDH: 4

Approved for: AK, AL, AR, FL, GA, IA, IL, IN, KS, KY, LA, MD, ME, MI, MN, MO, MS, MT, NC, ND, NE, NH, NJ, NM, NV, NY, OH, OK, OR, PA, SC, SD, TN, TX, UT, VA, VT, WI, WV, and WY

New Jersey Professional Competency Approval #24GP00025600

North Carolina Approved Sponsor #S-0695

Maryland Approved Provider of Continuing Professional Competency

Indiana Continuing Education Provider #CE21800088

Florida Provider #0009553 License #868

NYSED Sponsor #274

This document is the course text. You may review this material at your leisure before or after you purchase the course. In order to obtain credit for this course, complete the following steps:

- 1) Log in to My Account and purchase the course. If you don't have an account, go to New User to create an account.
- 2) After the course has been purchased, review the technical material and then complete the quiz at your convenience.
- 3) A Certificate of Completion is available once you pass the exam (70% or greater). If a passing grade is not obtained, you may take the quiz as many times as necessary until a passing grade is obtained (up to one year from the purchase date).

If you have any questions or technical difficulties, please call (508) 298-4787 or email us at admin@PDH-Pro.com.





DOE-HDBK-1012/3-92

DOE FUNDAMENTALS HANDBOOK
THERMODYNAMICS, HEAT TRANSFER,
AND FLUID FLOW
Volume 3 of 3



U.S. Department of Energy
Washington, D.C. 20585

FSC-6910

Distribution Statement A. Approved for public release; distribution is unlimited.

This document has been reproduced directly from the best available copy.

Available to DOE and DOE contractors from the Office of Scientific and Technical Information. P. O. Box 62, Oak Ridge, TN 37831; prices available from (615) 576-8401. FTS 626-8401.

Available to the public from the National Technical Information Service, U.S. Department of Commerce, 5285 Port Royal Rd., Springfield, VA 22161.

Order No. DE92019791

ABSTRACT

The *Thermodynamics, Heat Transfer, and Fluid Flow Fundamentals Handbook* was developed to assist nuclear facility operating contractors provide operators, maintenance personnel, and the technical staff with the necessary fundamentals training to ensure a basic understanding of the thermal sciences. The handbook includes information on thermodynamics and the properties of fluids; the three modes of heat transfer - conduction, convection, and radiation; and fluid flow, and the energy relationships in fluid systems. This information will provide personnel with a foundation for understanding the basic operation of various types of DOE nuclear facility fluid systems.

Key Words: Training Material, Thermodynamics, Heat Transfer, Fluid Flow, Bernoulli's Equation

FOREWORD

The *Department of Energy (DOE) Fundamentals Handbooks* consist of ten academic subjects, which include Mathematics; Classical Physics; Thermodynamics, Heat Transfer, and Fluid Flow; Instrumentation and Control; Electrical Science; Material Science; Mechanical Science; Chemistry; Engineering Symbology, Prints, and Drawings; and Nuclear Physics and Reactor Theory. The handbooks are provided as an aid to DOE nuclear facility contractors.

These handbooks were first published as Reactor Operator Fundamentals Manuals in 1985 for use by DOE Category A reactors. The subject areas, subject matter content, and level of detail of the Reactor Operator Fundamentals Manuals was determined from several sources. DOE Category A reactor training managers determined which materials should be included, and served as a primary reference in the initial development phase. Training guidelines from the commercial nuclear power industry, results of job and task analyses, and independent input from contractors and operations-oriented personnel were all considered and included to some degree in developing the text material and learning objectives.

The *DOE Fundamentals Handbooks* represent the needs of various DOE nuclear facilities' fundamentals training requirements. To increase their applicability to nonreactor nuclear facilities, the Reactor Operator Fundamentals Manual learning objectives were distributed to the Nuclear Facility Training Coordination Program Steering Committee for review and comment. To update their reactor-specific content, DOE Category A reactor training managers also reviewed and commented on the content. On the basis of feedback from these sources, information that applied to two or more DOE nuclear facilities was considered generic and was included. The final draft of each of these handbooks was then reviewed by these two groups. This approach has resulted in revised modular handbooks that contain sufficient detail such that each facility may adjust the content to fit their specific needs.

Each handbook contains an abstract, a foreword, an overview, learning objectives, and text material, and is divided into modules so that content and order may be modified by individual DOE contractors to suit their specific training needs. Each subject area is supported by a separate examination bank with an answer key.

The *DOE Fundamentals Handbooks* have been prepared for the Assistant Secretary for Nuclear Energy, Office of Nuclear Safety Policy and Standards, by the DOE Training Coordination Program. This program is managed by EG&G Idaho, Inc.

OVERVIEW

The *Department of Energy Fundamentals Handbook* entitled *Thermodynamics, Heat Transfer, and Fluid Flow* was prepared as an information resource for personnel who are responsible for the operation of the Department's nuclear facilities. A basic understanding of the thermal sciences is necessary for DOE nuclear facility operators, maintenance personnel, and the technical staff to safely operate and maintain the facility and facility support systems. The information in the handbook is presented to provide a foundation for applying engineering concepts to the job. This knowledge will help personnel more fully understand the impact that their actions may have on the safe and reliable operation of facility components and systems.

The *Thermodynamics, Heat Transfer, and Fluid Flow* handbook consists of three modules that are contained in three volumes. The following is a brief description of the information presented in each module of the handbook.

Volume 1 of 3

Module 1 - Thermodynamics

This module explains the properties of fluids and how those properties are affected by various processes. The module also explains how energy balances can be performed on facility systems or components and how efficiency can be calculated.

Volume 2 of 3

Module 2 - Heat Transfer

This module describes conduction, convection, and radiation heat transfer. The module also explains how specific parameters can affect the rate of heat transfer.

Volume 3 of 3

Module 3 - Fluid Flow

This module describes the relationship between the different types of energy in a fluid stream through the use of Bernoulli's equation. The module also discusses the causes of head loss in fluid systems and what factors affect head loss.

The information contained in this handbook is by no means all encompassing. An attempt to present the entire subject of thermodynamics, heat transfer, and fluid flow would be impractical. However, the *Thermodynamics, Heat Transfer, and Fluid Flow* handbook does present enough information to provide the reader with a fundamental knowledge level sufficient to understand the advanced theoretical concepts presented in other subject areas, and to better understand basic system and equipment operations.

**Department of Energy
Fundamentals Handbook**

**THERMODYNAMICS, HEAT TRANSFER,
AND FLUID FLOW,
Module 3
Fluid Flow**

TABLE OF CONTENTS

LIST OF FIGURES	iv
LIST OF TABLES	v
REFERENCES	vi
OBJECTIVES	vii
CONTINUITY EQUATION	1
Introduction	1
Properties of Fluids	2
Buoyancy	2
Compressibility	3
Relationship Between Depth and Pressure	3
Pascal's Law	7
Control Volume	8
Volumetric Flow Rate	9
Mass Flow Rate	9
Conservation of Mass	10
Steady-State Flow	10
Continuity Equation	11
Summary	16
LAMINAR AND TURBULENT FLOW	17
Flow Regimes	17
Laminar Flow	17
Turbulent Flow	17
Flow Velocity Profiles	18
Average (Bulk) Velocity	19
Viscosity	19
Ideal Fluid	19
Reynolds Number	19
Summary	20

TABLE OF CONTENTS (Cont.)

BERNOULLI'S EQUATION	21
General Energy Equation	21
Simplified Bernoulli Equation	22
Head	23
Energy Conversions in Fluid Systems	23
Restrictions on the Simplified Bernoulli Equation	25
Extended Bernoulli	25
Application of Bernoulli's Equation to a Venturi	27
Summary	30
HEAD LOSS	31
Head Loss	31
Friction Factor	31
Darcy's Equation	32
Minor Losses	34
Equivalent Piping Length	34
Summary	36
NATURAL CIRCULATION	37
Forced and Natural Circulation	37
Thermal Driving Head	37
Conditions Required for Natural Circulation	38
Example of Natural Circulation Cooling	39
Flow Rate and Temperature Difference	39
Summary	40
TWO-PHASE FLUID FLOW	41
Two-Phase Fluid Flow	41
Flow Instability	42
Pipe Whip	43
Water Hammer	43
Pressure spike	43
Steam Hammer	45
Operational Considerations	45
Summary	46

TABLE OF CONTENTS (Cont.)

CENTRIFUGAL PUMPS	47
Energy Conversion in a Centrifugal Pump	47
Operating Characteristics of a Centrifugal Pump	48
Cavitation	48
Net Positive Suction Head	49
Pump Laws	49
System Characteristic Curve	52
System Operating Point	52
System Use of Multiple Centrifugal Pumps	53
Centrifugal Pumps in Parallel	53
Centrifugal Pumps in Series	54
Summary	56
APPENDIX B Fluid Flow	B-1

LIST OF FIGURES

Figure 1	Pressure Versus Depth	3
Figure 2	Pascal's Law	7
Figure 3	Continuity Equation	12
Figure 4	"Y" Configuration for Example Problem	14
Figure 5	Laminar and Turbulent Flow Velocity Profiles	18
Figure 6	Venturi Meter	27
Figure 7	Typical Centrifugal Pump Characteristic Curve	48
Figure 8	Changing Speeds for Centrifugal Pump	51
Figure 9	Typical System Head Loss Curve	52
Figure 10	Operating Point for a Centrifugal Pump	52
Figure 11	Pump Characteristic Curve for Two Identical Centrifugal Pumps Used in Parallel	53
Figure 12	Operating Point for Two Parallel Centrifugal Pumps	54
Figure 13	Pump Characteristic Curve for Two Identical Centrifugal Pumps Used in Series	54
Figure 14	Operating Point for Two Centrifugal Pumps in Series	55
Figure B-1	Moody Chart	B-1

LIST OF TABLES

Table 1 Typical Values of $\frac{L_{eq}}{D}$ 34

REFERENCES

- Streeter, Victor L., Fluid Mechanics, 5th Edition, McGraw-Hill, New York, ISBN 07-062191-9.
- Knudsen, J. G. and Katz, D. L., Fluid Dynamics and Heat Transfer, McGraw-Hill, New York.
- McDonald, A. T. and Fox, R. W., Introduction to Fluid Mechanics, 2nd Edition, John Wiley and Sons, New York, ISBN 0-471-98440-X.
- Crane Company, Flow of Fluids Through Valves, Fittings, and Pipe, Crane Co. Technical Paper No. 410, Chicago, Illinois, 1957.
- Esposito, Anthony, Fluid Power with Applications, Prentice-Hall, Inc., New Jersey, ISBN 0-13-322701-4.
- Wallis, Graham, One-Dimensional Two-Phase Flow, McGraw-Hill, New York, 1969.
- Academic Program for Nuclear Power Plant Personnel, Volume III and IV, General Physics Corporation, Library of Congress Card #A 397747, June 1982 and April 1982.

TERMINAL OBJECTIVE

- 1.0 Given conditions affecting the fluid flow in a system, **EVALUATE** the effects on the operation of the system.

ENABLING OBJECTIVES

- 1.1 **DESCRIBE** how the density of a fluid varies with temperature.
- 1.2 **DEFINE** the term buoyancy.
- 1.3 **DESCRIBE** the relationship between the pressure in a fluid column and the density and depth of the fluid.
- 1.4 **STATE** Pascal's Law.
- 1.5 **DEFINE** the terms mass flow rate and volumetric flow rate.
- 1.6 **CALCULATE** either the mass flow rate or the volumetric flow rate for a fluid system.
- 1.7 **STATE** the principle of conservation of mass.
- 1.8 **CALCULATE** the fluid velocity or flow rate in a specified fluid system using the continuity equation.
- 1.9 **DESCRIBE** the characteristics and flow velocity profiles of laminar flow and turbulent flow.
- 1.10 **DEFINE** the property of viscosity.
- 1.11 **DESCRIBE** how the viscosity of a fluid varies with temperature.
- 1.12 **DESCRIBE** the characteristics of an ideal fluid.
- 1.13 **DESCRIBE** the relationship between the Reynolds number and the degree of turbulence of the flow.
- 1.14 **DESCRIBE** the relationship between Bernoulli's equation and the First Law of Thermodynamics.

ENABLING OBJECTIVES (Cont.)

- 1.15 **DEFINE** the term head with respect to its use in fluid flow.
- 1.16 **EXPLAIN** the energy conversions that take place in a fluid system between the velocity, elevation, and pressure heads as flow continues through a piping system.
- 1.17 Given the initial and final conditions of the system, **CALCULATE** the unknown fluid properties using the simplified Bernoulli equation.
- 1.18 **DESCRIBE** the restrictions applied to Bernoulli's equation when presented in its simplest form.
- 1.19 **EXPLAIN** how to extend the Bernoulli equation to more general applications.
- 1.20 **RELATE** Bernoulli's principle to the operation of a venturi.
- 1.21 **DEFINE** the terms head loss, frictional loss, and minor losses.
- 1.22 **DETERMINE** friction factors for various flow situations using the Moody chart.
- 1.23 **CALCULATE** the head loss in a fluid system due to frictional losses using Darcy's equation.
- 1.24 **CALCULATE** the equivalent length of pipe that would cause the same head loss as the minor losses that occur in individual components.
- 1.25 **DEFINE** natural circulation and forced circulation.
- 1.26 **DEFINE** thermal driving head.
- 1.27 **DESCRIBE** the conditions necessary for natural circulation to exist.
- 1.28 **EXPLAIN** the relationship between flow rate and temperature difference in natural circulation flow.
- 1.29 **DESCRIBE** how the operator can determine whether natural circulation exists in the reactor coolant system and other heat removal systems.
- 1.30 **DESCRIBE** how to enhance natural circulation flow.
- 1.31 **DEFINE** two-phase flow.

ENABLING OBJECTIVES (Cont.)

- 1.32 **DESCRIBE** two-phase flow including such phenomena as bubbly, slug, and annular flow.
- 1.33 **DESCRIBE** the problems associated with core flow oscillations and flow instability.
- 1.34 **DESCRIBE** the conditions that could lead to core flow oscillation and instability.
- 1.35 **DESCRIBE** the phenomenon of pipe whip.
- 1.36 **DESCRIBE** the phenomenon of water hammer.
- 1.37 **DEFINE** the terms net positive suction head and cavitation.
- 1.38 **CALCULATE** the new volumetric flow rate, head, or power for a variable speed centrifugal pump using the pump laws.
- 1.39 **DESCRIBE** the effect on system flow and pump head for the following changes:
 - a. Changing pump speeds
 - b. Adding pumps in parallel
 - c. Adding pumps in series

Intentionally Left Blank

CONTINUITY EQUATION

Understanding the quantities measured by the volumetric flow rate and mass flow rate is crucial to understanding other fluid flow topics. The continuity equation expresses the relationship between mass flow rates at different points in a fluid system under steady-state flow conditions.

- EO 1.1** **DESCRIBE** how the density of a fluid varies with temperature.
- EO 1.2** **DEFINE** the term buoyancy.
- EO 1.3** **DESCRIBE** the relationship between the pressure in a fluid column and the density and depth of the fluid.
- EO 1.4** **STATE** Pascal's Law.
- EO 1.5** **DEFINE** the terms mass flow rate and volumetric flow rate.
- EO 1.6** **CALCULATE** either the mass flow rate or the volumetric flow rate for a fluid system.
- EO 1.7** **STATE** the principle of conservation of mass.
- EO 1.8** **CALCULATE** the fluid velocity or flow rate in a specified fluid system using the continuity equation.
-

Introduction

Fluid flow is an important part of most industrial processes; especially those involving the transfer of heat. Frequently, when it is desired to remove heat from the point at which it is generated, some type of fluid is involved in the heat transfer process. Examples of this are the cooling water circulated through a gasoline or diesel engine, the air flow past the windings of a motor, and the flow of water through the core of a nuclear reactor. Fluid flow systems are also commonly used to provide lubrication.

Fluid flow in the nuclear field can be complex and is not always subject to rigorous mathematical analysis. Unlike solids, the particles of fluids move through piping and components at different velocities and are often subjected to different accelerations.

Even though a detailed analysis of fluid flow can be extremely difficult, the basic concepts involved in fluid flow problems are fairly straightforward. These basic concepts can be applied in solving fluid flow problems through the use of simplifying assumptions and average values, where appropriate. Even though this type of analysis would not be sufficient in the engineering design of systems, it is very useful in understanding the operation of systems and predicting the approximate response of fluid systems to changes in operating parameters.

The basic principles of fluid flow include three concepts or principles; the first two of which the student has been exposed to in previous manuals. The first is the principle of momentum (leading to equations of fluid forces) which was covered in the manual on Classical Physics. The second is the conservation of energy (leading to the First Law of Thermodynamics) which was studied in thermodynamics. The third is the conservation of mass (leading to the continuity equation) which will be explained in this module.

Properties of Fluids

A *fluid* is any substance which flows because its particles are not rigidly attached to one another. This includes liquids, gases and even some materials which are normally considered solids, such as glass. Essentially, fluids are materials which have no repeating crystalline structure.

Several properties of fluids were discussed in the Thermodynamics section of this text. These included temperature, pressure, mass, specific volume and density. *Temperature* was defined as the relative measure of how hot or cold a material is. It can be used to predict the direction that heat will be transferred. *Pressure* was defined as the force per unit area. Common units for pressure are pounds force per square inch (psi). *Mass* was defined as the quantity of matter contained in a body and is to be distinguished from weight, which is measured by the pull of gravity on a body. The *specific volume* of a substance is the volume per unit mass of the substance. Typical units are ft³/lbm. *Density*, on the other hand, is the mass of a substance per unit volume. Typical units are lbm/ft³. Density and specific volume are the inverse of one another. Both density and specific volume are dependant on the temperature and somewhat on the pressure of the fluid. As the temperature of the fluid increases, the density decreases and the specific volume increases. Since liquids are considered incompressible, an increase in pressure will result in no change in density or specific volume of the liquid. In actuality, liquids can be slightly compressed at high pressures, resulting in a slight increase in density and a slight decrease in specific volume of the liquid.

Buoyancy

Buoyancy is defined as the tendency of a body to float or rise when submerged in a fluid. We all have had numerous opportunities of observing the buoyant effects of a liquid. When we go swimming, our bodies are held up almost entirely by the water. Wood, ice, and cork float on water. When we lift a rock from a stream bed, it suddenly seems heavier on emerging from the water. Boats rely on this buoyant force to stay afloat. The amount of this buoyant effect was first computed and stated by the Greek philosopher Archimedes. When a body is placed in a fluid, it is buoyed up by a force equal to the weight of the water that it displaces.

If a body weighs more than the liquid it displaces, it sinks but will appear to lose an amount of weight equal to that of the displaced liquid, as our rock. If the body weighs less than that of the displaced liquid, the body will rise to the surface eventually floating at such a depth that will displace a volume of liquid whose weight will just equal its own weight. A floating body displaces its own weight of the fluid in which it floats.

Compressibility

Compressibility is the measure of the change in volume a substance undergoes when a pressure is exerted on the substance. Liquids are generally considered to be incompressible. For instance, a pressure of 16,400 psig will cause a given volume of water to decrease by only 5% from its volume at atmospheric pressure. Gases on the other hand, are very compressible. The volume of a gas can be readily changed by exerting an external pressure on the gas

Relationship Between Depth and Pressure

Anyone who dives under the surface of the water notices that the pressure on his eardrums at a depth of even a few feet is noticeably greater than atmospheric pressure. Careful measurements show that the pressure of a liquid is directly proportional to the depth, and for a given depth the liquid exerts the same pressure in all directions.

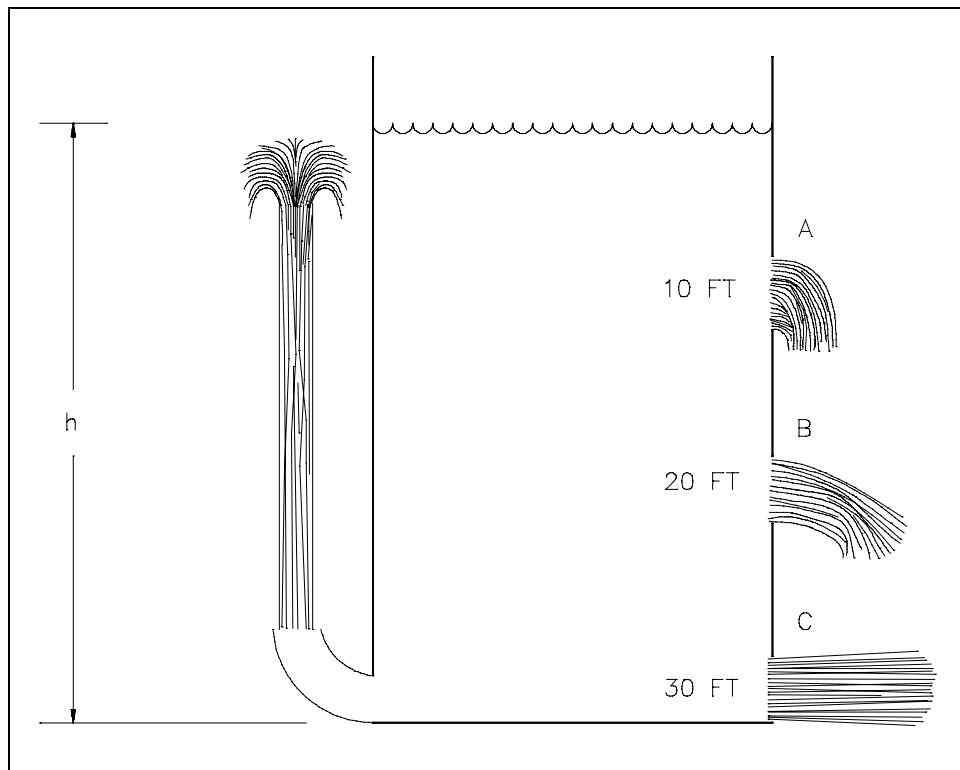

Figure 1 Pressure Versus Depth

As shown in Figure 1 the pressure at different levels in the tank varies and this causes the fluid to leave the tank at varying velocities. Pressure was defined to be force per unit area. In the case of this tank, the force is due to the weight of the water above the point where the pressure is being determined.

Example:

$$\begin{aligned} \text{Pressure} &= \frac{\text{Force}}{\text{Area}} \\ &= \frac{\text{Weight}}{\text{Area}} \\ P &= \frac{m g}{A g_c} \\ &= \frac{\rho V g}{A g_c} \end{aligned}$$

where:

m = mass in lbm

g = acceleration due to earth's gravity $32.17 \frac{\text{ft}}{\text{sec}^2}$

g_c = $32.17 \frac{\text{lbm-ft}}{\text{lbf-sec}^2}$

A = area in ft^2

V = volume in ft^3

ρ = density of fluid in $\frac{\text{lbm}}{\text{ft}^3}$

The volume is equal to the cross-sectional area times the height (h) of liquid. Substituting this in to the above equation yields:

$$P = \frac{\rho A h g}{A g_c}$$

$$P = \frac{\rho h g}{g_c}$$

This equation tells us that the pressure exerted by a column of water is directly proportional to the height of the column and the density of the water and is independent of the cross-sectional area of the column. The pressure thirty feet below the surface of a one inch diameter standpipe is the same as the pressure thirty feet below the surface of a large lake.

Example 1:

If the tank in Figure 1 is filled with water that has a density of 62.4 lbm/ft³, calculate the pressures at depths of 10, 20, and 30 feet.

Solution:

$$\begin{aligned}
 P &= \frac{\rho h g}{g_c} \\
 P_{10 \text{ feet}} &= \left(62.4 \frac{\text{lbm}}{\text{ft}^3}\right) (10 \text{ ft}) \left(\frac{32.17 \frac{\text{ft}}{\text{sec}^2}}{32.17 \frac{\text{lbm-ft}}{\text{lbf-sec}^2}}\right) \\
 &= 624 \frac{\text{lbf}}{\text{ft}^2} \left(\frac{1 \text{ ft}^2}{144 \text{ in}^2}\right) \\
 &= 4.33 \frac{\text{lbf}}{\text{in}^2} \\
 P_{20 \text{ feet}} &= \left(62.4 \frac{\text{lbm}}{\text{ft}^3}\right) (20 \text{ ft}) \left(\frac{32.17 \frac{\text{ft}}{\text{sec}^2}}{32.17 \frac{\text{lbm-ft}}{\text{lbf-sec}^2}}\right) \\
 &= 1248 \frac{\text{lbf}}{\text{ft}^2} \left(\frac{1 \text{ ft}^2}{144 \text{ in}^2}\right) \\
 &= 8.67 \frac{\text{lbf}}{\text{in}^2}
 \end{aligned}$$

$$\begin{aligned}
 P_{30 \text{ feet}} &= \left(62.4 \frac{\text{lbm}}{\text{ft}^3}\right) (30 \text{ ft}) \left(\frac{32.17 \frac{\text{ft}}{\text{sec}^2}}{32.17 \frac{\text{lbm-ft}}{\text{lbf-sec}^2}} \right) \\
 &= 1872 \frac{\text{lbf}}{\text{ft}^2} \left(\frac{1 \text{ ft}^2}{144 \text{ in}^2} \right) \\
 &= 13.00 \frac{\text{lbf}}{\text{in}^2}
 \end{aligned}$$

Example 2:

A cylindrical water tank 40 ft high and 20 ft in diameter is filled with water that has a density of 61.9 lbm/ft³.

- (a) What is the water pressure on the bottom of the tank?
- (b) What is the average force on the bottom?

Solution:

$$\begin{aligned}
 \text{(a)} \quad P &= \frac{\rho h g}{g_c} \\
 P &= \left(61.9 \frac{\text{lbm}}{\text{ft}^3}\right) (40 \text{ ft}) \left(\frac{32.17 \frac{\text{ft}}{\text{sec}^2}}{32.17 \frac{\text{lbm-ft}}{\text{lbf-sec}^2}} \right) \\
 &= 2476 \frac{\text{lbf}}{\text{ft}^2} \left(\frac{1 \text{ ft}^2}{144 \text{ in}^2} \right) \\
 &= 17.2 \frac{\text{lbf}}{\text{in}^2}
 \end{aligned}$$

$$(b) \quad \text{Pressure} = \frac{\text{Force}}{\text{Area}}$$

$$\text{Force} = (\text{Pressure}) (\text{Area})$$

$$\text{Area} = \pi r^2$$

$$\begin{aligned} F &= \left(17.2 \frac{\text{lbf}}{\text{in}^2} \right) \pi (10 \text{ ft})^2 \left(\frac{144 \text{ in}^2}{1 \text{ ft}^2} \right) \\ &= 7.78 \times 10^5 \text{ lbf} \end{aligned}$$

Pascal's Law

The pressure of the liquids in each of the previously cited cases has been due to the weight of the liquid. Liquid pressures may also result from application of external forces on the liquid. Consider the following examples. Figure 2 represents a container completely filled with liquid. A, B, C, D, and E represent pistons of equal cross-sectional areas fitted into the walls of the vessel. There will be forces acting on the pistons C, D, and E due to the pressures caused by the different depths of the liquid. Assume that the forces on the pistons due to the pressure caused by the weight of the liquid are as follows: A = 0 lbf, B = 0 lbf, C = 10 lbf, D = 30 lbf, and E = 25 lbf. Now let an external force of 50 lbf be applied to piston A. This external force will cause the pressure at all points in the container to increase by the same amount. Since the pistons all have the same cross-sectional area, the increase in pressure will result in the forces on the pistons all increasing by 50 lbf. So if an external force of 50 lbf is applied to piston A, the force exerted by the fluid on the other pistons will now be as follows: B = 50 lbf, C = 60 lbf, D = 80 lbf, and E = 75 lbf.

This effect of an external force on a confined fluid was first stated by Pascal in 1653.

Pressure applied to a confined fluid is transmitted undiminished throughout the confining vessel of the system.

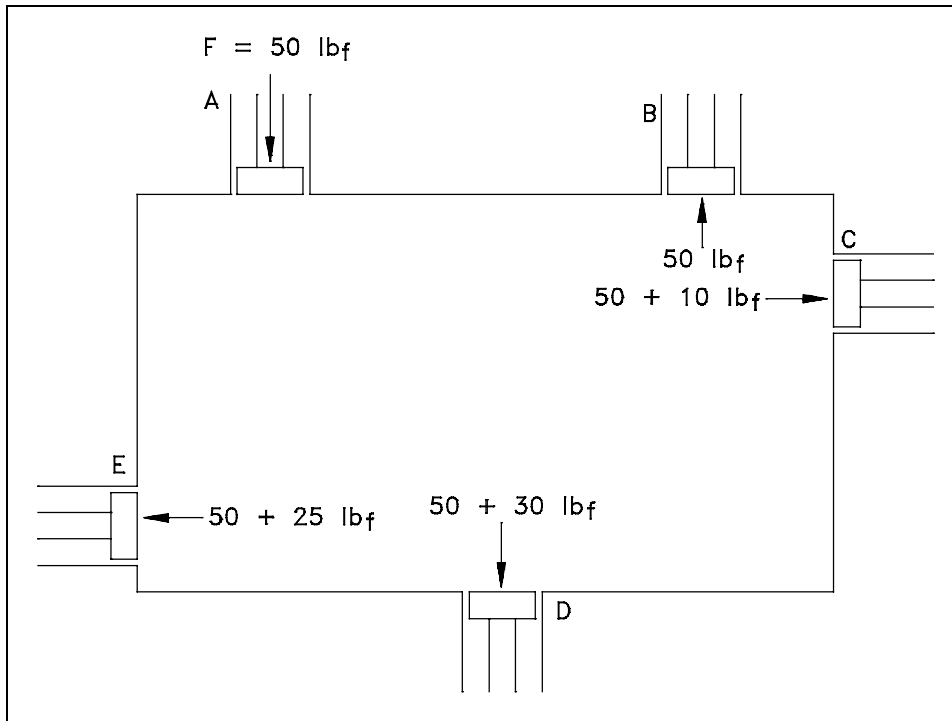

Figure 2 Pascal's Law

Control Volume

In thermodynamics, a *control volume* was defined as a fixed region in space where one studies the masses and energies crossing the boundaries of the region. This concept of a control volume is also very useful in analyzing fluid flow problems. The boundary of a control volume for fluid flow is usually taken as the physical boundary of the part through which the flow is occurring. The control volume concept is used in fluid dynamics applications, utilizing the continuity, momentum, and energy principles mentioned at the beginning of this chapter. Once the control volume and its boundary are established, the various forms of energy crossing the boundary with the fluid can be dealt with in equation form to solve the fluid problem. Since fluid flow problems usually treat a fluid crossing the boundaries of a control volume, the control volume approach is referred to as an "open" system analysis, which is similar to the concepts studied in thermodynamics. There are special cases in the nuclear field where fluid does not cross the control boundary. Such cases are studied utilizing the "closed" system approach.

Regardless of the nature of the flow, all flow situations are found to be subject to the established basic laws of nature that engineers have expressed in equation form. Conservation of mass and conservation of energy are always satisfied in fluid problems, along with Newton's laws of motion. In addition, each problem will have physical constraints, referred to mathematically as boundary conditions, that must be satisfied before a solution to the problem will be consistent with the physical results.

Volumetric Flow Rate

The *volumetric flow rate* (\dot{V}) of a system is a measure of the volume of fluid passing a point in the system per unit time. The volumetric flow rate can be calculated as the product of the cross-sectional area (A) for flow and the average flow velocity (v).

$$\dot{V} = A v \quad (3-1)$$

If area is measured in square feet and velocity in feet per second, Equation 3-1 results in volumetric flow rate measured in cubic feet per second. Other common units for volumetric flow rate include gallons per minute, cubic centimeters per second, liters per minute, and gallons per hour.

Example:

A pipe with an inner diameter of 4 inches contains water that flows at an average velocity of 14 feet per second. Calculate the volumetric flow rate of water in the pipe.

Solution:

Use Equation 3-1 and substitute for the area.

$$\dot{V} = (\pi r^2) v$$

$$\dot{V} = (3.14) \left(\frac{2}{12} \text{ ft}\right)^2 \left(14 \frac{\text{ft}}{\text{sec}}\right)$$

$$\dot{V} = 1.22 \frac{\text{ft}^3}{\text{sec}}$$

Mass Flow Rate

The *mass flow rate* (\dot{m}) of a system is a measure of the mass of fluid passing a point in the system per unit time. The mass flow rate is related to the volumetric flow rate as shown in Equation 3-2 where ρ is the density of the fluid.

$$\dot{m} = \rho \dot{V} \quad (3-2)$$

If the volumetric flow rate is in cubic feet per second and the density is in pounds-mass per cubic foot, Equation 3-2 results in mass flow rate measured in pounds-mass per second. Other common units for measurement of mass flow rate include kilograms per second and pounds-mass per hour.

Replacing \dot{V} in Equation 3-2 with the appropriate terms from Equation 3-1 allows the direct calculation of the mass flow rate.

$$\dot{m} = \rho A v \quad (3-3)$$

Example:

The water in the pipe of the previous example had a density of 62.44 lbm/ft³. Calculate the mass flow rate.

Solution:

$$\dot{m} = \rho \dot{V}$$

$$\dot{m} = (62.44 \frac{\text{lbm}}{\text{ft}^3}) (1.22 \frac{\text{ft}^3}{\text{sec}})$$

$$\dot{m} = 76.2 \frac{\text{lbm}}{\text{sec}}$$

Conservation of Mass

In thermodynamics, you learned that energy can neither be created nor destroyed, only changed in form. The same is true for mass. Conservation of mass is a principle of engineering that states that all mass flow rates into a control volume are equal to all mass flow rates out of the control volume plus the rate of change of mass within the control volume. This principle is expressed mathematically by Equation 3-4.

$$\dot{m}_{\text{in}} = \dot{m}_{\text{out}} + \frac{\Delta m}{\Delta t} \quad (3-4)$$

where:

$$\frac{\Delta m}{\Delta t} = \text{the increase or decrease of the mass within the control volume over a (specified time period)}$$

Steady-State Flow

Steady-state flow refers to the condition where the fluid properties at any single point in the system do not change over time. These fluid properties include temperature, pressure, and velocity. One of the most significant properties that is constant in a steady-state flow system is the system mass flow rate. This means that there is no accumulation of mass within any component in the system.

Continuity Equation

The continuity equation is simply a mathematical expression of the principle of conservation of mass. For a control volume that has a single inlet and a single outlet, the principle of conservation of mass states that, for steady-state flow, the mass flow rate into the volume must equal the mass flow rate out. The continuity equation for this situation is expressed by Equation 3-5.

$$\dot{m}_{\text{inlet}} = \dot{m}_{\text{outlet}} \quad (3-5)$$

$$(\rho Av)_{\text{inlet}} = (\rho Av)_{\text{outlet}}$$

For a control volume with multiple inlets and outlets, the principle of conservation of mass requires that the sum of the mass flow rates into the control volume equal the sum of the mass flow rates out of the control volume. The continuity equation for this more general situation is expressed by Equation 3-6.

$$\sum \dot{m}_{\text{inlets}} = \sum \dot{m}_{\text{outlets}} \quad (3-6)$$

One of the simplest applications of the continuity equation is determining the change in fluid velocity due to an expansion or contraction in the diameter of a pipe.

Example: Continuity Equation - Piping Expansion

Steady-state flow exists in a pipe that undergoes a gradual expansion from a diameter of 6 in. to a diameter of 8 in. The density of the fluid in the pipe is constant at 60.8 lbm/ft³. If the flow velocity is 22.4 ft/sec in the 6 in. section, what is the flow velocity in the 8 in. section?

Solution:

From the continuity equation we know that the mass flow rate in the 6 in. section must equal the mass flow rate in the 8 in. section. Letting the subscript 1 represent the 6 in. section and 2 represent the 8 in. section we have the following.

$$\dot{m}_1 = \dot{m}_2$$

$$\rho_1 A_1 v_1 = \rho_2 A_2 v_2$$

$$v_2 = v_1 \frac{\rho_1}{\rho_2} \frac{A_1}{A_2}$$

$$= v_1 \frac{\pi r_1^2}{\pi r_2^2}$$

$$= \left(22.4 \frac{\text{ft}}{\text{sec}} \right) \frac{(3 \text{ in})^2}{(4 \text{ in})^2}$$

$$v_2 = 12.6 \frac{\text{ft}}{\text{sec}}$$

So by using the continuity equation, we find that the increase in pipe diameter from 6 to 8 inches caused a decrease in flow velocity from 22.4 to 12.6 ft/sec.

The continuity equation can also be used to show that a decrease in pipe diameter will cause an increase in flow velocity.

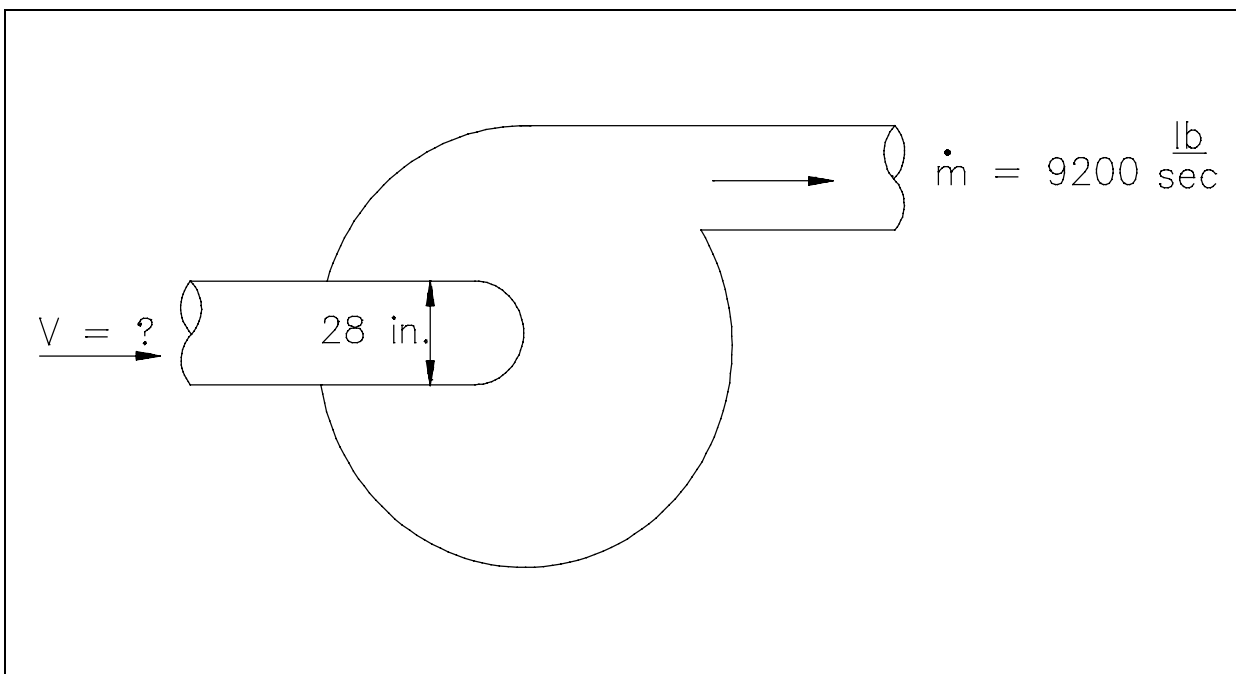

Figure 3 Continuity Equation

Example: Continuity Equation - Centrifugal Pump

The inlet diameter of the reactor coolant pump shown in Figure 3 is 28 in. while the outlet flow through the pump is 9200 lbm/sec. The density of the water is 49 lbm/ft³. What is the velocity at the pump inlet?

Solution:

$$A_{\text{inlet}} = \pi r^2 = (3.14) \left(14 \text{ in} \left(\frac{1 \text{ ft}}{12 \text{ in}} \right) \right)^2$$

$$= 4.28 \text{ ft}^2$$

$$\dot{m}_{\text{inlet}} = \dot{m}_{\text{outlet}} = 9200 \frac{\text{lbm}}{\text{sec}}$$

$$(\rho A v)_{\text{inlet}} = 9200 \frac{\text{lbm}}{\text{sec}}$$

$$v_{\text{inlet}} = \frac{9200 \frac{\text{lbm}}{\text{sec}}}{A \rho}$$

$$= \frac{9200 \frac{\text{lbm}}{\text{sec}}}{(4.28 \text{ ft}^2) \left(49 \frac{\text{lbm}}{\text{ft}^3} \right)}$$

$$v_{\text{inlet}} = 43.9 \frac{\text{ft}}{\text{sec}}$$

The above example indicates that the flow rate into the system is the same as that out of the system. The same concept is true even though more than one flow path may enter or leave the system at the same time. The mass balance is simply adjusted to state that the sum of all flows entering the system is equal to the sum of all the flows leaving the system if steady-state conditions exist. An example of this physical case is included in the following example.

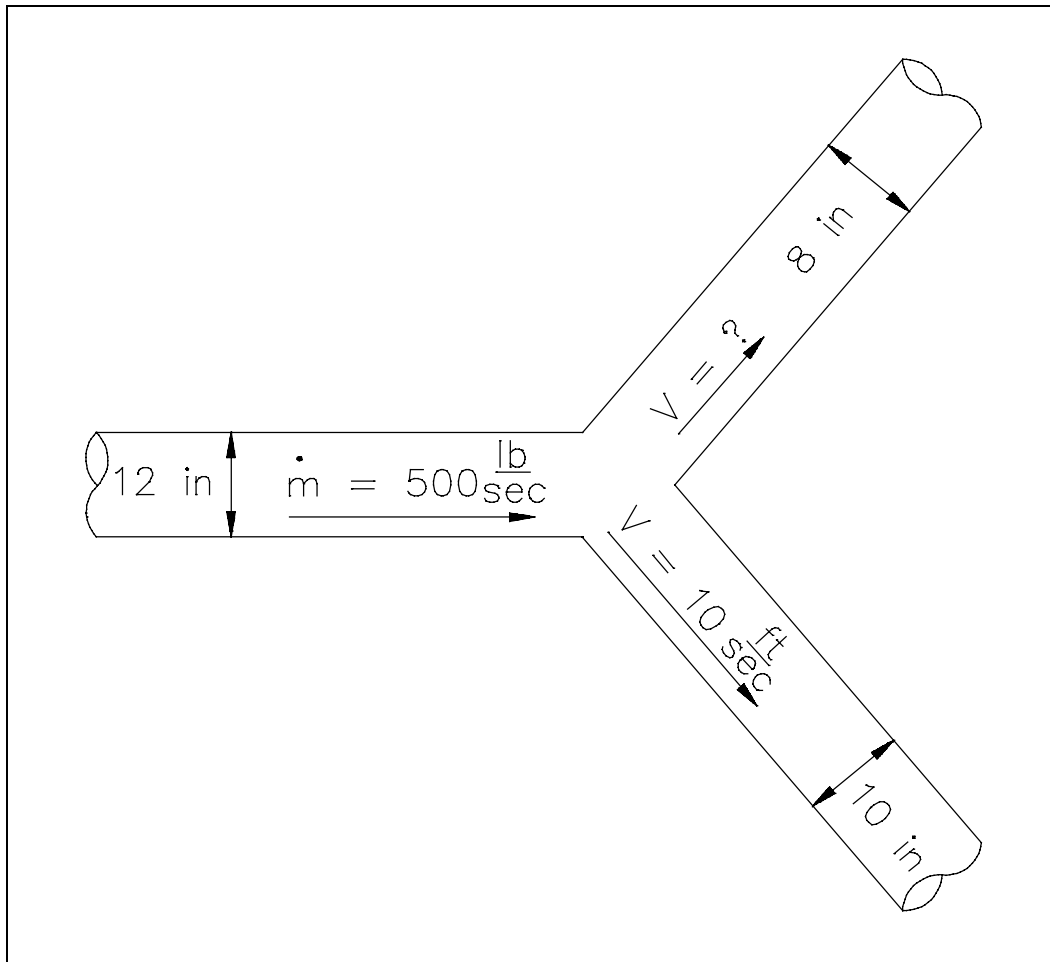

Figure 4 "Y" Configuration for Example Problem

Example: Continuity Equation - Multiple Outlets

A piping system has a "Y" configuration for separating the flow as shown in Figure 4. The diameter of the inlet leg is 12 in., and the diameters of the outlet legs are 8 and 10 in. The velocity in the 10 in. leg is 10 ft/sec. The flow through the main portion is 500 lbm/sec. The density of water is 62.4 lbm/ft^3 . What is the velocity out of the 8 in. pipe section?

Solution:

$$A_8 = \pi \left(4 \text{ in.} \cdot \frac{1 \text{ ft}}{12 \text{ in.}} \right)^2$$

$$= 0.349 \text{ ft}^2$$

$$A_{10} = \pi \left(5 \text{ in.} \cdot \frac{1 \text{ ft}}{12 \text{ in.}} \right)^2$$

$$= 0.545 \text{ ft}^2$$

$$\Sigma \dot{m}_{\text{inlets}} = \Sigma \dot{m}_{\text{outlets}}$$

$$\dot{m}_{12} = \dot{m}_{10} + \dot{m}_8$$

$$\dot{m}_8 = \dot{m}_{12} - \dot{m}_{10}$$

$$(\rho A v)_8 = \dot{m}_{12} - (\rho A v)_{10}$$

$$v_8 = \frac{\dot{m}_{12} - (\rho A v)_{10}}{(\rho A)_8}$$

$$= \frac{500 \frac{\text{lbm}}{\text{sec}} - \left(62.4 \frac{\text{lbm}}{\text{ft}^3} \right) (0.545 \text{ ft}^2) \left(10 \frac{\text{ft}}{\text{sec}} \right)}{\left(62.4 \frac{\text{lbm}}{\text{ft}^3} \right) (0.349 \text{ ft}^2)}$$

$$v_8 = 7.3 \frac{\text{ft}}{\text{sec}}$$

Summary

The main points of this chapter are summarized on the next page.

Continuity Equation Summary

- Density changes in a fluid are inversely proportional to temperature changes.
- Buoyancy is the tendency of a body to float or rise when submerged in a fluid.
- The pressure exerted by a column of water is directly proportional to the height of the column and the density of the water.

$$P = \frac{\rho h g}{g_c}$$

- Pascal's law states that pressure applied to a confined fluid is transmitted undiminished throughout the confining vessel of a system.
- Volumetric flow rate is the volume of fluid per unit time passing a point in a fluid system.
- Mass flow rate is the mass of fluid per unit time passing a point in a fluid system.
- The volumetric flow rate is calculated by the product of the average fluid velocity and the cross-sectional area for flow.

$$\dot{V} = A v$$

- The mass flow rate is calculated by the product of the volumetric flow rate and the fluid density.

$$\dot{m} = \rho A v$$

- The principle of conservation of mass states that all mass flow rates into a control volume are equal to all mass flow rates out of the control volume plus the rate of change of mass within the control volume.
- For a control volume with a single inlet and outlet, the continuity equation can be expressed as follows:

$$\dot{m}_{\text{inlet}} = \dot{m}_{\text{outlet}}$$

- For a control volume with multiple inlets and outlets, the continuity equation is:

$$\sum \dot{m}_{\text{inlets}} = \sum \dot{m}_{\text{outlets}}$$

LAMINAR AND TURBULENT FLOW

The characteristics of laminar and turbulent flow are very different. To understand why turbulent or laminar flow is desirable in the operation of a particular system, it is necessary to understand the characteristics of laminar and turbulent flow.

- EO 1.9** **DESCRIBE the characteristics and flow velocity profiles of laminar flow and turbulent flow.**
- EO 1.10** **DEFINE the property of viscosity.**
- EO 1.11** **DESCRIBE how the viscosity of a fluid varies with temperature.**
- EO 1.12** **DESCRIBE the characteristics of an ideal fluid.**
- EO 1.13** **DESCRIBE the relationship between the Reynolds number and the degree of turbulence of the flow.**
-

Flow Regimes

All fluid flow is classified into one of two broad categories or regimes. These two flow regimes are laminar flow and turbulent flow. The flow regime, whether laminar or turbulent, is important in the design and operation of any fluid system. The amount of fluid friction, which determines the amount of energy required to maintain the desired flow, depends upon the mode of flow. This is also an important consideration in certain applications that involve heat transfer to the fluid.

Laminar Flow

Laminar flow is also referred to as streamline or viscous flow. These terms are descriptive of the flow because, in laminar flow, (1) layers of water flowing over one another at different speeds with virtually no mixing between layers, (2) fluid particles move in definite and observable paths or streamlines, and (3) the flow is characteristic of viscous (thick) fluid or is one in which viscosity of the fluid plays a significant part.

Turbulent Flow

Turbulent flow is characterized by the irregular movement of particles of the fluid. There is no definite frequency as there is in wave motion. The particles travel in irregular paths with no observable pattern and no definite layers.

Flow Velocity Profiles

Not all fluid particles travel at the same velocity within a pipe. The shape of the velocity curve (the velocity profile across any given section of the pipe) depends upon whether the flow is laminar or turbulent. If the flow in a pipe is laminar, the velocity distribution at a cross section will be parabolic in shape with the maximum velocity at the center being about twice the average velocity in the pipe. In turbulent flow, a fairly flat velocity distribution exists across the section of pipe, with the result that the entire fluid flows at a given single value. Figure 5 helps illustrate the above ideas. The velocity of the fluid in contact with the pipe wall is essentially zero and increases the further away from the wall.

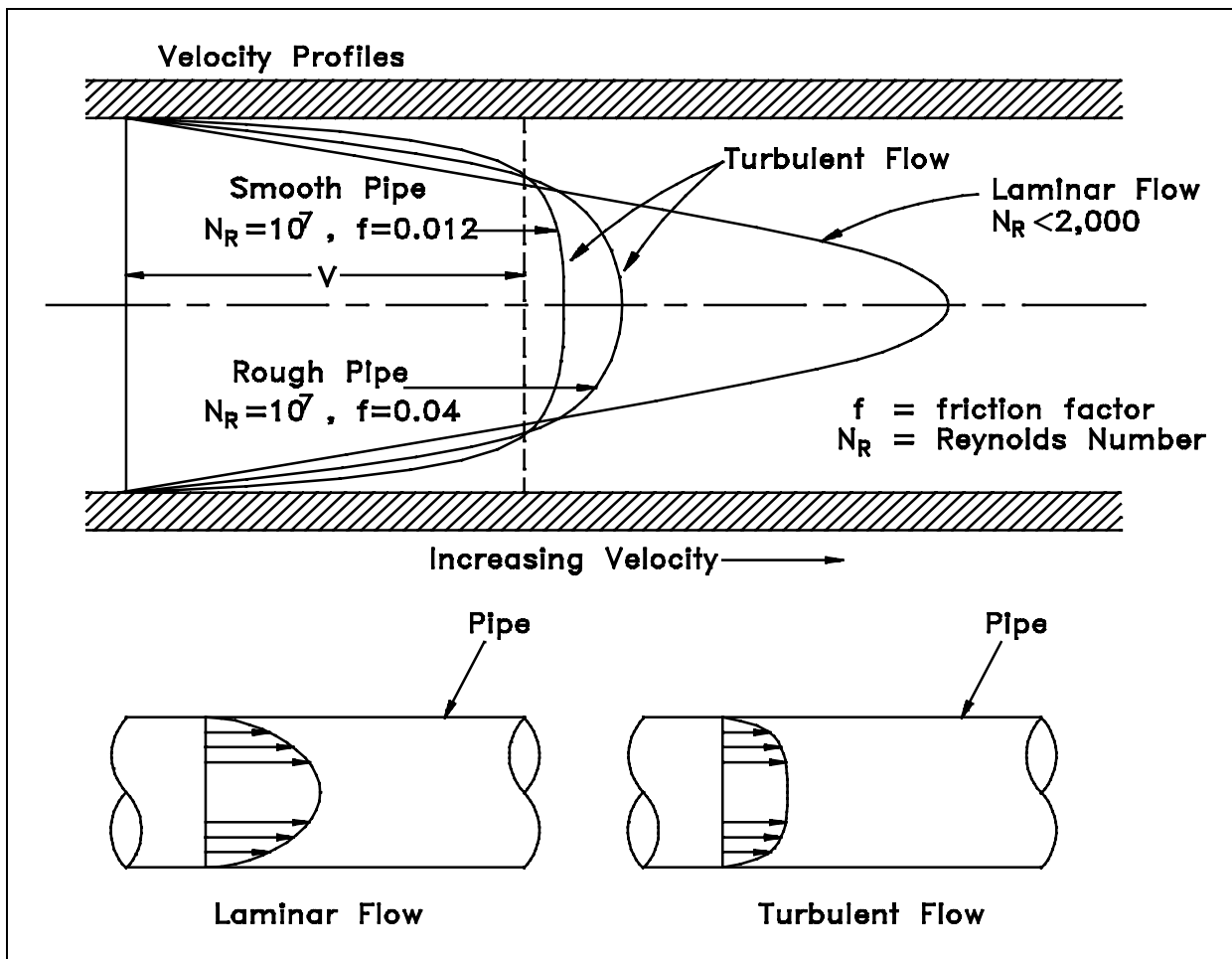

Figure 5 Laminar and Turbulent Flow Velocity Profiles

Note from Figure 5 that the velocity profile depends upon the surface condition of the pipe wall. A smoother wall results in a more uniform velocity profile than a rough pipe wall.

Average (Bulk) Velocity

In many fluid flow problems, instead of determining exact velocities at different locations in the same flow cross-section, it is sufficient to allow a single average velocity to represent the velocity of all fluid at that point in the pipe. This is fairly simple for turbulent flow since the velocity profile is flat over the majority of the pipe cross-section. It is reasonable to assume that the average velocity is the same as the velocity at the center of the pipe.

If the flow regime is laminar (the velocity profile is parabolic), the problem still exists of trying to represent the "average" velocity at any given cross-section since an average value is used in the fluid flow equations. Technically, this is done by means of integral calculus. Practically, the student should use an average value that is half of the center line value.

Viscosity

Viscosity is a fluid property that measures the resistance of the fluid to deforming due to a shear force. Viscosity is the internal friction of a fluid which makes it resist flowing past a solid surface or other layers of the fluid. Viscosity can also be considered to be a measure of the resistance of a fluid to flowing. A thick oil has a high viscosity; water has a low viscosity. The unit of measurement for absolute viscosity is:

$$\mu = \text{absolute viscosity of fluid (lbf-sec/ft}^2\text{)}.$$

The viscosity of a fluid is usually significantly dependent on the temperature of the fluid and relatively independent of the pressure. For most fluids, as the temperature of the fluid increases, the viscosity of the fluid decreases. An example of this can be seen in the lubricating oil of engines. When the engine and its lubricating oil are cold, the oil is very viscous, or thick. After the engine is started and the lubricating oil increases in temperature, the viscosity of the oil decreases significantly and the oil seems much thinner.

Ideal Fluid

An *ideal fluid* is one that is incompressible and has no viscosity. Ideal fluids do not actually exist, but sometimes it is useful to consider what would happen to an ideal fluid in a particular fluid flow problem in order to simplify the problem.

Reynolds Number

The flow regime (either laminar or turbulent) is determined by evaluating the Reynolds number of the flow (refer to figure 5). The *Reynolds number*, based on studies of Osborn Reynolds, is a dimensionless number comprised of the physical characteristics of the flow. Equation 3-7 is used to calculate the Reynolds number (N_R) for fluid flow.

$$N_R = \rho v D / \mu g_c \quad (3-7)$$

where:

- N_R = Reynolds number (unitless)
- v = average velocity (ft/sec)
- D = diameter of pipe (ft)
- μ = absolute viscosity of fluid (lbf-sec/ft²)
- ρ = fluid mass density (lbm/ft³)
- g_c = gravitational constant (32.2 ft-lbm/lbf-sec²)

For practical purposes, if the Reynolds number is less than 2000, the flow is laminar. If it is greater than 3500, the flow is turbulent. Flows with Reynolds numbers between 2000 and 3500 are sometimes referred to as transitional flows. Most fluid systems in nuclear facilities operate with turbulent flow. Reynolds numbers can be conveniently determined using a Moody Chart; an example of which is shown in Appendix B. Additional detail on the use of the Moody Chart is provided in subsequent text.

Summary

The main points of this chapter are summarized below.

Laminar and Turbulent Flow Summary

- **Laminar Flow**
Layers of water flow over one another at different speeds with virtually no mixing between layers.
The flow velocity profile for laminar flow in circular pipes is parabolic in shape, with a maximum flow in the center of the pipe and a minimum flow at the pipe walls.
The average flow velocity is approximately one half of the maximum velocity.
- **Turbulent Flow**
The flow is characterized by the irregular movement of particles of the fluid.
The flow velocity profile for turbulent flow is fairly flat across the center section of a pipe and drops rapidly extremely close to the walls.
The average flow velocity is approximately equal to the velocity at the center of the pipe.
- Viscosity is the fluid property that measures the resistance of the fluid to deforming due to a shear force. For most fluids, temperature and viscosity are inversely proportional.
- An ideal fluid is one that is incompressible and has no viscosity.
- An increasing Reynolds number indicates an increasing turbulence of flow.

BERNOULLI'S EQUATION

Bernoulli's equation is a special case of the general energy equation that is probably the most widely-used tool for solving fluid flow problems. It provides an easy way to relate the elevation head, velocity head, and pressure head of a fluid. It is possible to modify Bernoulli's equation in a manner that accounts for head losses and pump work.

- EO 1.14** **DESCRIBE** the relationship between Bernoulli's equation and the First Law of Thermodynamics.
- EO 1.15** **DEFINE** the term head with respect to its use in fluid flow.
- EO 1.16** **EXPLAIN** the energy conversions that take place in a fluid system between the velocity, elevation, and pressure heads as flow continues through a piping system.
- EO 1.17** **Given** the initial and final conditions of the system, **CALCULATE** the unknown fluid properties using the simplified Bernoulli equation.
- EO 1.18** **DESCRIBE** the restrictions applied to Bernoulli's equation when presented in its simplest form.
- EO 1.19** **EXPLAIN** how to extend the Bernoulli equation to more general applications.
- EO 1.20** **RELATE** Bernoulli's principle to the operation of a venturi.

General Energy Equation

The conservation of energy principle states that energy can be neither created nor destroyed. This is equivalent to the First Law of Thermodynamics, which was used to develop the general energy equation in the module on thermodynamics. Equation 3-8 is a statement of the general energy equation for an open system.

$$Q + (U + PE + KE + PV)_{in} = W + (U + PE + KE + PV)_{out} + (U + PE + KE + PV)_{stored} \quad (3-8)$$

where:

- Q = heat (Btu)
- U = internal energy (Btu)
- PE = potential energy (ft-lbf)
- KE = kinetic energy (ft-lbf)
- P = pressure (lbf/ft²)
- V = volume (ft³)
- W = work (ft-lbf)

Simplified Bernoulli Equation

Bernoulli's equation results from the application of the general energy equation and the first law of thermodynamics to a steady flow system in which no work is done on or by the fluid, no heat is transferred to or from the fluid, and no change occurs in the internal energy (i.e., no temperature change) of the fluid. Under these conditions, the general energy equation is simplified to Equation 3-9.

$$(PE + KE + PV)_1 = (PE + KE + PV)_2 \quad (3-9)$$

Substituting appropriate expressions for the potential energy and kinetic energy, Equation 3-9 can be rewritten as Equation 3-10.

$$\frac{mgz_1}{g_c} + \frac{mv_1^2}{2g_c} + P_1V_1 = \frac{mgz_2}{g_c} + \frac{mv_2^2}{2g_c} + P_2V_2 \quad (3-10)$$

where:

- m = mass (lbm)
- z = height above reference (ft)
- v = average velocity (ft/sec)
- g = acceleration due to gravity (32.17 ft/sec²)
- g_c = gravitational constant, (32.17 ft-lbm/lbf-sec²)

Note: The factor g_c is only required when the English System of measurement is used and mass is measured in pound mass. It is essentially a conversion factor needed to allow the units to come out directly. No factor is necessary if mass is measured in slugs or if the metric system of measurement is used.

Each term in Equation 3-10 represents a form of energy possessed by a moving fluid (potential, kinetic, and pressure related energies). In essence, the equation physically represents a balance of the KE, PE, PV energies so that if one form of energy increases, one or more of the others will decrease to compensate and vice versa.

Multiplying all terms in Equation 3-10 by the factor g_c/mg results in the form of Bernoulli's equation shown by Equation 3-11.

$$z_1 + \frac{v_1^2}{2g} + P_1 v_1 \frac{g_c}{g} = z_2 + \frac{v_2^2}{2g} + P_2 v_2 \frac{g_c}{g} \quad (3-11)$$

Head

Since the units for all the different forms of energy in Equation 3-11 are measured in units of distance, these terms are sometimes referred to as "heads" (pressure head, velocity head, and elevation head). The term *head* is used by engineers in reference to pressure. It is a reference to the height, typically in feet, of a column of water that a given pressure will support. Each of the energies possessed by a fluid can be expressed in terms of head. The elevation head represents the potential energy of a fluid due to its elevation above a reference level. The velocity head represents the kinetic energy of the fluid. It is the height in feet that a flowing fluid would rise in a column if all of its kinetic energy were converted to potential energy. The pressure head represents the flow energy of a column of fluid whose weight is equivalent to the pressure of the fluid.

The sum of the elevation head, velocity head, and pressure head of a fluid is called the total head. Thus, Bernoulli's equation states that the total head of the fluid is constant.

Energy Conversions in Fluid Systems

Bernoulli's equation makes it easy to examine how energy transfers take place among elevation head, velocity head, and pressure head. It is possible to examine individual components of piping systems and determine what fluid properties are varying and how the energy balance is affected.

If a pipe containing an ideal fluid undergoes a gradual expansion in diameter, the continuity equation tells us that as the diameter and flow area get bigger, the flow velocity must decrease to maintain the same mass flow rate. Since the outlet velocity is less than the inlet velocity, the velocity head of the flow must decrease from the inlet to the outlet. If the pipe lies horizontal, there is no change in elevation head; therefore, the decrease in velocity head must be compensated for by an increase in pressure head. Since we are considering an ideal fluid that is incompressible, the specific volume of the fluid will not change. The only way that the pressure head for an incompressible fluid can increase is for the pressure to increase. So the Bernoulli equation indicates that a decrease in flow velocity in a horizontal pipe will result in an increase in pressure.

If a constant diameter pipe containing an ideal fluid undergoes a decrease in elevation, the same net effect results, but for different reasons. In this case the flow velocity and the velocity head must be constant to satisfy the mass continuity equation.

So the decrease in elevation head can only be compensated for by an increase in pressure head. Again, the fluid is incompressible so the increase in pressure head must result in an increase in pressure.

Although the Bernoulli equation has several restrictions placed upon it, there are many physical fluid problems to which it is applied. As in the case of the conservation of mass, the Bernoulli equation may be applied to problems in which more than one flow may enter or leave the system at the same time. Of particular note is the fact that series and parallel piping system problems are solved using the Bernoulli equation.

Example: Bernoulli's Equation

Assume frictionless flow in a long, horizontal, conical pipe. The diameter is 2.0 ft at one end and 4.0 ft at the other. The pressure head at the smaller end is 16 ft of water. If water flows through this cone at a rate of 125.6 ft³/sec, find the velocities at the two ends and the pressure head at the larger end.

Solution:

$$\dot{V}_1 = A_1 v_1$$

$$v_1 = \frac{\dot{V}_1}{A_1} \qquad v_2 = \frac{\dot{V}_2}{A_2}$$

$$v_1 = \frac{125.6 \frac{\text{ft}^3}{\text{sec}}}{\pi(1 \text{ ft})^2} \qquad v_2 = \frac{125.6 \frac{\text{ft}^3}{\text{sec}}}{\pi(2 \text{ ft})^2}$$

$$v_1 = 40 \frac{\text{ft}}{\text{sec}} \qquad v_2 = 10 \frac{\text{ft}}{\text{sec}}$$

$$z_1 + \frac{v_1^2}{2g} + P_1 v_1 \frac{g_c}{g} = z_2 + \frac{v_2^2}{2g} + P_2 v_2 \frac{g_c}{g}$$

$$P_2 v_2 \frac{g_c}{g} = P_1 v_1 \frac{g_c}{g} + (z_1 - z_2) + \frac{v_1^2 - v_2^2}{2g}$$

$$= 16 \text{ ft} + 0 \text{ ft} + \frac{\left(40 \frac{\text{ft}}{\text{sec}}\right)^2 - \left(10 \frac{\text{ft}}{\text{sec}}\right)^2}{2 \left(32.17 \frac{\text{ft-lbm}}{\text{lbf-sec}^2}\right)}$$

$$= 39.3 \text{ ft}$$

Restrictions on the Simplified Bernoulli Equation

Practical applications of the simplified Bernoulli Equation to real piping systems is not possible due to two restrictions. One serious restriction of the Bernoulli equation in its present form is that no fluid friction is allowed in solving piping problems. Therefore, Equation 3-10 only applies to ideal fluids. However, in reality, the total head possessed by the fluid cannot be transferred completely from one point to another because of friction. Taking these losses of head into account would provide a much more accurate description of what takes place physically. This is especially true because one purpose of a pump in a fluid system is to overcome the losses in pressure due to pipe friction.

The second restriction on Bernoulli's equation is that no work is allowed to be done on or by the fluid. This restriction prevents two points in a fluid stream from being analyzed if a pump exists between the two points. Since most flow systems include pumps, this is a significant limitation. Fortunately, the simplified Bernoulli equation can be modified in a manner that satisfactorily deals with both head losses and pump work.

Extended Bernoulli

The Bernoulli equation can be modified to take into account gains and losses of head. The resulting equation, referred to as the Extended Bernoulli equation, is very useful in solving most fluid flow problems. In fact, the Extended Bernoulli equation is probably used more than any other fluid flow equation. Equation 3-12 is one form of the Extended Bernoulli equation.

$$z_1 + \frac{v_1^2}{2g} + P_1 v_1 \frac{g_c}{g} + H_p = z_2 + \frac{v_2^2}{2g} + P_2 v_2 \frac{g_c}{g} + H_f \quad (3-12)$$

where:

- z = height above reference level (ft)
- v = average velocity of fluid (ft/sec)
- P = pressure of fluid (lbf/ft²)
- v = specific volume of fluid (ft³/lbm)
- H_p = head added by pump (ft)
- H_f = head loss due to fluid friction (ft)
- g = acceleration due to gravity (ft/sec²)

The head loss due to fluid friction (H_f) represents the energy used in overcoming friction caused by the walls of the pipe. Although it represents a loss of energy from the standpoint of fluid flow, it does not normally represent a significant loss of total energy of the fluid. It also does not violate the law of conservation of energy since the head loss due to friction results in an equivalent increase in the internal energy (u) of the fluid. These losses are greatest as the fluid flows through entrances, exits, pumps, valves, fittings, and any other piping with rough inner surfaces.

Most techniques for evaluating head loss due to friction are empirical (based almost exclusively on experimental evidence) and are based on a proportionality constant called the friction factor (f), which will be discussed in the next section.

Example: Extended Bernoulli

Water is pumped from a large reservoir to a point 65 feet higher than the reservoir. How many feet of head must be added by the pump if 8000 lbm/hr flows through a 6-inch pipe and the frictional head loss is 2 feet? The density of the fluid is 62.4 lbm/ft³, and the cross-sectional area of a 6-inch pipe is 0.2006 ft².

Solution:

To use the modified form of Bernoulli's equation, reference points are chosen at the surface of the reservoir (point 1) and at the outlet of the pipe (point 2). The pressure at the surface of the reservoir is the same as the pressure at the exit of the pipe, i.e., atmospheric pressure. The velocity at point 1 will be essentially zero.

Using the equation for the mass flow rate to determine the velocity at point 2:

$$\dot{m}_2 = \rho A_2 v_2$$

$$v_2 = \frac{\dot{m}_2}{\rho A_2}$$

$$v_2 = \frac{8000 \frac{\text{lbm}}{\text{hr}}}{\left(62.4 \frac{\text{lbm}}{\text{ft}^3}\right) (0.2006 \text{ ft}^2)}$$

$$v_2 = 639 \frac{\text{ft}}{\text{hr}} \left(\frac{1 \text{ hr}}{3600 \text{ sec}} \right)$$

$$v_2 = 0.178 \frac{\text{ft}}{\text{sec}}$$

Now we can use the Extended Bernoulli equation to determine the required pump head.

$$z_1 + \frac{v_1^2}{2g} + P_1 v_1 \frac{g_c}{g} + H_p = z_2 + \frac{v_2^2}{2g} + P_2 v_2 \frac{g_c}{g} + H_f$$

$$H_p = (z_2 - z_1) + \left(\frac{v_2^2 - v_1^2}{2g} \right) + (P_2 - P_1) v \frac{g_c}{g} + H_f$$

$$= 65 \text{ ft} + \frac{\left(0.178 \frac{\text{ft}}{\text{sec}} \right)^2 - \left(0 \frac{\text{ft}}{\text{sec}} \right)^2}{2 \left(32.17 \frac{\text{ft-lbm}}{\text{lbf-sec}^2} \right)} + 0 \text{ ft} + 2 \text{ ft}$$

$$H_p = 67 \text{ ft}$$

The student should note that the solution of this example problem has a numerical value that "makes sense" from the data given in the problem. The total head increase of 67 ft. is due primarily to the 65 ft. evaluation increase and the 2 ft. of friction head.

Application of Bernoulli's Equation to a Venturi

Many plant components, such as a venturi, may be analyzed using Bernoulli's equation and the continuity equation. A venturi is a flow measuring device that consists of a gradual contraction followed by a gradual expansion. An example of a venturi is shown in Figure 6. By measuring the differential pressure between the inlet of the venturi (point 1) and the throat of the venturi (point 2), the flow velocity and mass flow rate can be determined based on Bernoulli's equation.

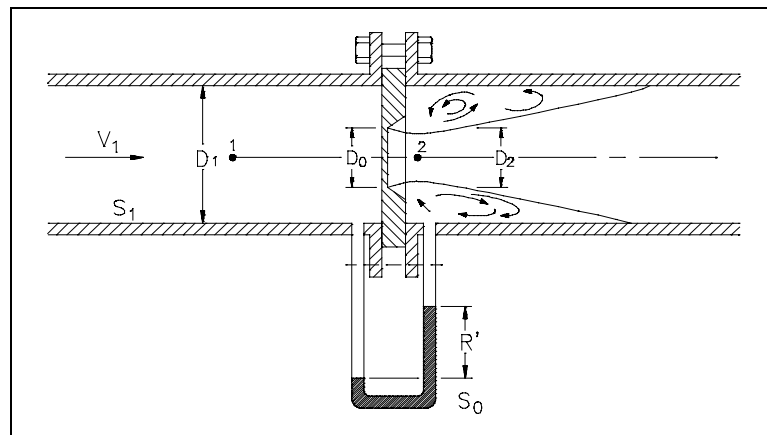

Figure 6 Venturi Meter

Bernoulli's equation states that the total head of the flow must be constant. Since the elevation does not change significantly, if at all, between points 1 and 2, the elevation head at the two points will be essentially the same and will cancel out of the equation. So Bernoulli's equation simplifies to Equation 3-13 for a venturi.

$$\frac{v_1^2}{2g} + P_1 v_1 \frac{g_c}{g} = \frac{v_2^2}{2g} + P_2 v_2 \frac{g_c}{g} \quad (3-13)$$

Applying the continuity equation to points 1 and 2 allows us to express the flow velocity at point 1 as a function of the flow velocity at point 2 and the ratio of the two flow areas.

$$\rho_1 A_1 v_1 = \rho_2 A_2 v_2$$

$$v_1 = \frac{\rho_2 A_2 v_2}{\rho_1 A_1}$$

$$v_1 = v_2 \frac{A_2}{A_1}$$

Using algebra to rearrange Equation 3-13 and substituting the above result for v_1 allows us to solve for v_2 .

$$\frac{v_2^2 - v_1^2}{2g} = (P_1 - P_2) v \frac{g_c}{g}$$

$$v_2^2 - \left(v_2 \frac{A_2}{A_1} \right)^2 = (P_1 - P_2) 2v g_c$$

$$v_2^2 \left(1 - \left(\frac{A_2}{A_1} \right)^2 \right) = (P_1 - P_2) 2v g_c$$

$$v_2^2 = \frac{(P_1 - P_2) 2vg_c}{\left(1 - \left(\frac{A_2}{A_1}\right)^2\right)}$$

$$v_2 = \sqrt{\frac{(P_1 - P_2) 2vg_c}{\left(1 - \left(\frac{A_2}{A_1}\right)^2\right)}}$$

$$v_2 = \sqrt{P_1 - P_2} \sqrt{\frac{2vg_c}{\left(1 - \left(\frac{A_2}{A_1}\right)^2\right)}}$$

Therefore the flow velocity at the throat of the venturi and the volumetric flow rate are directly proportional to the square root of the differential pressure.

The pressures at the upstream section and throat are actual pressures, and velocities from Bernoulli's equation without a loss term are theoretical velocities. When losses are considered in the energy equation, the velocities are actual velocities. First, with the Bernoulli equation (that is, without a head-loss term), the theoretical velocity at the throat is obtained. Then by multiplying this by the venturi factor (C_v), which accounts for friction losses and equals 0.98 for most venturis, the actual velocity is obtained. The actual velocity times the actual area of the throat determines the actual discharge volumetric flow rate.

The pressure drop, $P_1 - P_2$, across the venturi can be used to measure the flow rate using a U-tube manometer as shown in Figure 6. The reading, R , of the manometer is proportional to the pressure drop and thus the velocity of the fluid.

Summary

The main points of this chapter are summarized below.

Bernoulli's Equation Summary

- Bernoulli's equation is an application of the First Law of Thermodynamics.
- Bernoulli's equation is an application of the general energy equation to a steady flow system in which no work is done on or by the fluid, no heat is transferred to or from the fluid, and no change occurs in the internal energy of the fluid.
- Head is the term used to describe pressure exerted on or by a fluid.
- As fluid flows in a piping system, changes in elevation, velocity, and pressure heads must be consistent so that Bernoulli's equation is satisfied.
- Bernoulli's equation can be modified to take into account friction losses and pump work.
- A venturi can be used to determine mass flow rates due to changes in pressure and fluid velocity.
- The volumetric flow rate through a venturi is directly proportional to the square root of the differential pressure between the venturi's inlet and its throat.

HEAD LOSS

The head loss that occurs in pipes is dependent on the flow velocity, pipe length and diameter, and a friction factor based on the roughness of the pipe and the Reynolds number of the flow. The head loss that occurs in the components of a flow path can be correlated to a piping length that would cause an equivalent head loss.

- EO 1.21** **DEFINE** the terms head loss, frictional loss, and minor losses.
- EO 1.22** **DETERMINE** friction factors for various flow situations using the Moody chart.
- EO 1.23** **CALCULATE** the head loss in a fluid system due to frictional losses using Darcy's equation.
- EO 1.24** **CALCULATE** the equivalent length of pipe that would cause the same head loss as the minor losses that occur in individual components.
-

Head Loss

Head loss is a measure of the reduction in the total head (sum of elevation head, velocity head and pressure head) of the fluid as it moves through a fluid system. Head loss is unavoidable in real fluids. It is present because of: the friction between the fluid and the walls of the pipe; the friction between adjacent fluid particles as they move relative to one another; and the turbulence caused whenever the flow is redirected or affected in any way by such components as piping entrances and exits, pumps, valves, flow reducers, and fittings.

Frictional loss is that part of the total head loss that occurs as the fluid flows through straight pipes. The head loss for fluid flow is directly proportional to the length of pipe, the square of the fluid velocity, and a term accounting for fluid friction called the friction factor. The head loss is inversely proportional to the diameter of the pipe.

$$\text{Head Loss} \propto f \frac{Lv^2}{D}$$

Friction Factor

The friction factor has been determined to depend on the Reynolds number for the flow and the degree of roughness of the pipe's inner surface.

The quantity used to measure the roughness of the pipe is called the relative roughness, which equals the average height of surface irregularities (ϵ) divided by the pipe diameter (D).

$$\text{Relative Roughness} = \frac{\epsilon}{D}$$

The value of the friction factor is usually obtained from the Moody Chart (Figure B-1 of Appendix B). The Moody Chart can be used to determine the friction factor based on the Reynolds number and the relative roughness.

Example:

Determine the friction factor (f) for fluid flow in a pipe that has a Reynolds number of 40,000 and a relative roughness of 0.01.

Solution:

Using the Moody Chart, a Reynolds number of 40,000 intersects the curve corresponding to a relative roughness of 0.01 at a friction factor of 0.04.

Darcy's Equation

The frictional head loss can be calculated using a mathematical relationship that is known as Darcy's equation for head loss. The equation takes two distinct forms. The first form of Darcy's equation determines the losses in the system associated with the length of the pipe.

$$H_f = f \frac{L v^2}{D 2 g} \quad (3-14)$$

where:

- f = friction factor (unitless)
- L = length of pipe (ft)
- D = diameter of pipe (ft)
- v = fluid velocity (ft/sec)
- g = gravitational acceleration (ft/sec²)

Example: Darcy's Head Loss Equation

A pipe 100 feet long and 20 inches in diameter contains water at 200°F flowing at a mass flow rate of 700 lbm/sec. The water has a density of 60 lbm/ft³ and a viscosity of 1.978 x 10⁻⁷ lbf-sec/ft². The relative roughness of the pipe is 0.00008. Calculate the head loss for the pipe.

Solution:

The sequence of steps necessary to solve this problem is first to determine the flow velocity. Second, using the flow velocity and the fluid properties given, calculate the Reynolds number. Third, determine the friction factor from the Reynolds number and the relative roughness. Finally, use Darcy's equation to determine the head loss.

$$\dot{m} = \rho Av$$

$$v = \frac{\dot{m}}{\rho A}$$

$$= \frac{700 \frac{\text{lbm}}{\text{sec}}}{\left(60 \frac{\text{lbm}}{\text{ft}^3}\right) \pi (10 \text{ in})^2 \frac{1 \text{ ft}^2}{144 \text{ in}^2}}$$

$$v = 5.35 \frac{\text{ft}}{\text{sec}}$$

$$N_R = \frac{\rho v D}{\mu g_c}$$

$$N_R = \frac{\left(60 \frac{\text{lbm}}{\text{ft}^3}\right) \left(5.35 \frac{\text{ft}}{\text{sec}}\right) \left(20 \text{ in} \frac{1 \text{ ft}}{12 \text{ in}}\right)}{1.978 \times 10^{-7} \frac{\text{lbf-sec}}{\text{ft}^2} 32.17 \frac{\text{ft-lbm}}{\text{lbf-sec}^2}} = 8.4 \times 10^7$$

Use the Moody Chart for a Reynolds number of 8.4×10^7 and a relative roughness of 0.00008.

$$f = 0.012$$

$$H_f = f \frac{L}{D} \frac{v^2}{2g}$$

$$= (0.012) \frac{100 \text{ ft}}{20 \text{ in} \left(\frac{1 \text{ ft}}{12 \text{ in}}\right)} \cdot \frac{\left(5.35 \frac{\text{ft}}{\text{sec}}\right)^2}{2 \left(32.17 \frac{\text{ft}}{\text{sec}^2}\right)}$$

$$H_f = 0.32 \text{ ft}$$

Minor Losses

The losses that occur in pipelines due to bends, elbows, joints, valves, etc. are sometimes called *minor losses*. This is a misnomer because in many cases these losses are more important than the losses due to pipe friction, considered in the preceding section. For all minor losses in turbulent flow, the head loss varies as the square of the velocity. Thus a convenient method of expressing the minor losses in flow is by means of a loss coefficient (k). Values of the loss coefficient (k) for typical situations and fittings is found in standard handbooks. The form of Darcy's equation used to calculate minor losses of individual fluid system components is expressed by Equation 3-15.

$$H_f = k \frac{v^2}{2g} \quad (3-15)$$

Equivalent Piping Length

Minor losses may be expressed in terms of the equivalent length (L_{eq}) of pipe that would have the same head loss for the same discharge flow rate. This relationship can be found by setting the two forms of Darcy's equation equal to each other.

$$f \frac{L}{D} \frac{v^2}{2g} = k \frac{v^2}{2g}$$

This yields two relationships that are useful.

$$L_{eq} = k \frac{D}{f} \quad (3-16)$$

$$k = f \frac{L_{eq}}{D} \quad (3-17)$$

Typical values of L_{eq}/D for common piping system components are listed in Table 1. The equivalent length of piping that will cause the same head loss as a particular component can be determined by multiplying the value of L_{eq}/D for that component by the diameter of the pipe. The higher the value of L_{eq}/D , the longer the equivalent length of pipe.

TABLE 1	
Typical Values of $\frac{L_{eq}}{D}$	
Item	$\frac{L_{eq}}{D}$
<u>Globe Valve</u>	
Conventional	400
Y-Pattern	160
<u>Gate Valve</u>	
Fully Open	10
75% Open	35
50% Open	150
25% Open	900
<u>Standard Tee</u>	
Flow through Run	10
Flow through Branch	60
90° Standard Elbow	30
45° Standard Elbow	16
Return Bend	50

Example:

A fully-open gate valve is in a pipe with a diameter of 10 inches. What equivalent length of pipe would cause the same head loss as the gate valve?

Solution:

From Table 1, we find that the value of L_{eq}/D for a fully-open gate valve is 10.

$$\begin{aligned}
 L_{eq} &= (L/D) D \\
 &= 10 (10 \text{ inches}) \\
 &= 100 \text{ inches}
 \end{aligned}$$

By adding the equivalent lengths of all components to the actual length of pipe in a system we can obtain the L_{eq} value for the entire piping system.

Summary

The main points of this chapter are summarized below.

Head Loss Summary

- Head loss is the reduction in the total head (sum of potential head, velocity head, and pressure head) of a fluid caused by the friction present in the fluid's motion.
- Frictional loss is that part of the total head loss that occurs as the fluid flows through straight pipes.
- Minor losses are the head losses that occur due to bends, elbows, joints, valves, and other components. Any time the flow experiences a change in direction or a change in cross-sectional area, it will experience a head loss.
- The friction factor for fluid flow can be determined using a Moody Chart if the relative roughness of the pipe and the Reynolds number of the flow can be determined.
- Darcy's equation can be used to calculate frictional losses.
- A special form of Darcy's equation can be used to calculate minor losses.
- The length of pipe that would cause the same head loss as a valve or fitting can be determined by multiplying the value of L/D for the component found in handbooks or vendor manuals by the diameter of the pipe.

NATURAL CIRCULATION

Natural circulation is the circulation of fluid within piping systems or open pools that is due to the density changes caused by temperature differences. Natural circulation does not require any mechanical devices to maintain flow.

- EO 1.25** **DEFINE** natural circulation and forced circulation.
- EO 1.26** **DEFINE** thermal driving head.
- EO 1.27** **DESCRIBE** the conditions necessary for natural circulation to exist.
- EO 1.28** **EXPLAIN** the relationship between flow rate and temperature difference in natural circulation flow.
- EO 1.29** **DESCRIBE** how the operator can determine whether natural circulation exists in the reactor coolant system and other heat removal systems.
- EO 1.30** **DESCRIBE** how to enhance natural circulation flow.
-

Forced and Natural Circulation

In the previous chapters on fluid flow, it was explained that any time that fluid flows there is some friction associated with the movement, which will cause head loss. It was pointed out that this head loss is commonly compensated for in piping systems by pumps that do work on the fluid, compensating for the head loss due to friction. Circulation of fluid in systems by pumps is referred to as *forced circulation*.

It is possible to design some fluid systems in a manner that does not require the presence of pumps to provide circulation. The head required to compensate for the head losses is created by density gradients and elevation changes. Flow that occurs under these circumstances is called *natural circulation*.

Thermal Driving Head

Thermal driving head is the force that causes natural circulation to take place. It is caused by the difference in density between two bodies or areas of fluid.

Consider two equal volumes of the same type of fluid. If the two volumes are not at the same temperature, then the volume with the higher temperature will also have a lower density and, therefore, less mass. Since the volume at the higher temperature will have a lower mass, it will also have less force exerted on it by gravity. This difference in the force of gravity exerted on the fluid will tend to cause the hotter fluid to rise and the colder fluid to sink.

This effect is seen in many places. One example of this is a hot air balloon. The force causing a hot air balloon to rise is a result of a difference in density between the hot air inside the balloon and the cooler air surrounding it.

Heat added to the air in the balloon adds energy to the molecules of air. The movement of the air molecules increases and the air molecules take up more space. The air molecules inside the balloon take up more space than the same amount of air molecules outside the balloon. This means the hot air is less dense and lighter than the surrounding air. Since the air in the balloon is less dense, gravity has less effect on it. The result is that the balloon weighs less than the surrounding air. Gravity pulls cooler air down into the space occupied by the balloon. The downward movement of the cooler air forces the balloon out of the space previously occupied, and the balloon rises.

Conditions Required for Natural Circulation

Natural circulation will only occur if the correct conditions exist. Even after natural circulation has begun, removal of any one of these conditions will cause the natural circulation to stop. The conditions for natural circulation are as follows.

1. A temperature difference exists (heat source and heat sink exists).
2. The heat source is at a lower elevation than the heat sink.
3. The fluids must be in contact with each other.

There must be two bodies of fluid at different temperatures. This could also be one body of fluid with areas of different temperatures. The difference in temperature is necessary to cause a density difference in the fluid. The density difference is the driving force for natural circulation flow.

The difference in temperature must be maintained for the natural circulation to continue. Addition of heat by a heat source must exist at the high temperature area. Continuous removal of heat by a heat sink must exist at the low temperature area. Otherwise the temperatures would eventually equalize, and no further circulation would occur.

The heat source must be at a lower elevation than the heat sink. As shown by the example of the balloon, a warmer fluid is less dense and will tend to rise, and a cooler fluid is more dense and will tend to sink. To take advantage of the natural movement of warm and cool fluids, the heat source and heat sink must be at the proper elevations.

The two areas must be in contact so that flow between the areas is possible. If the flow path is obstructed or blocked, then natural circulation cannot occur.

Example of Natural Circulation Cooling

Natural circulation is frequently the primary means of cooling for pool-type reactors and for irradiated fuel assemblies stored in pools of water after removal from the reactor. The heat source is the fuel assembly. The heat sink is the bulk of the water in the pool.

Water at the bottom of a fuel assembly absorbs energy generated by the assembly. The water increases in temperature and decreases in density. Gravity pulls cooler (more dense) water into the bottom of the assembly displacing the warmer water. The warmer (lighter) water is forced to give up its position to the cooler (heavier) water. The warmer (lighter) water rises higher in the assembly. As water travels up the length of the assembly, it absorbs more energy. The water becomes lighter and lighter being continuously forced upward by more dense water moving in below it. In turn, the cooler water absorbs energy from the assembly and is also forced to rise as natural circulation flow continues. Water exiting the top of the fuel assembly gives up its energy as it mixes with the bulk of the water in the pool. The bulk of the water in the pool is commonly cooled by circulation through heat exchangers in a separate process.

Flow Rate and Temperature Difference

The thermal driving head that causes natural circulation is due to the density change caused by a temperature difference. In general, the greater the temperature difference between the hot and cold areas of fluid, the greater the thermal driving head and the resulting flow rate. However, it is good practice to keep the hot fluid subcooled to prevent a change of phase from occurring. It is possible to have natural circulation take place in two-phase flow, but it is usually more difficult to maintain flow.

Various parameters can be used to indicate or verify natural circulation is occurring. This is dependent on plant type. For instance for a pressurized water reactor (PWR) selected Reactor Coolant System (RCS) parameters that would be used are as follows.

1. RCS ΔT ($T_{\text{Hot}} - T_{\text{Cold}}$) should be 25-80% of the full power value and either steady or slowly decreasing. This indicates that the decay heat is being removed from the system at an adequate rate to maintain or reduce core temperatures.
2. RCS Hot and Cold leg temperatures should be steady or slowly decreasing. Again, this indicates that heat is being removed and the decay heat load is decreasing as expected.
3. Steam generator steam pressure (secondary side pressure) should be following RCS temperature. This verifies that the steam generator is removing heat from the RCS coolant.

If natural circulation for a PWR is in progress or is imminent, several actions can be performed to ensure or enhance core cooling capabilities. First, pressurizer level can be maintained greater than 50%. Secondly, maintain the RCS subcooled by 15°F or greater.

Both of these actions will help ensure steam/vapor pockets are not formed in the RCS where they would restrict RCS flow. Thirdly, maintain steam generator water level \geq normal range. This provides an adequate heat sink to ensure heat removal is sufficient to prevent boiling of the RCS.

Summary

The main points of this chapter are listed below.

Natural Circulation Flow Summary

- Natural circulation flow is circulation of a fluid without the use of mechanical devices.
- Forced circulation flow is circulation of a fluid through a system by pumps.
- Thermal driving head is the driving force for natural circulation caused by the difference in density between two areas of fluid.
- Three items are necessary to support natural circulation:
 - There must be a heat sink and a heat source.
 - The heat source must be located below the heat sink.
 - Flowpaths must exist between the warm fluid and the cold fluid.
- Generally, the greater the temperature difference, the higher the natural circulation flow rate.
- Natural circulation in a PWR can be verified by monitoring:
 - RCS ΔT - 25%-80% full power value
 - $T_{\text{Hot}} / T_{\text{Cold}}$ - steady or slowly decreasing
 - S/G steam pressure - tracking RCS temperature
- Natural circulation in a PWR can be enhanced by:
 - maintain pressurizer level $>50\%$
 - maintain RCS $\geq 15^{\circ}\text{F}$ subcooling
 - maintain adequate heat sink, S/G level \geq normal range

TWO-PHASE FLUID FLOW

Water at saturation conditions may exist as both a fluid and a vapor. This mixture of steam and water can cause unusual flow characteristics within fluid systems.

- EO 1.31** **DEFINE** two-phase flow.
- EO 1.32** **DESCRIBE** two-phase flow including such phenomena as bubbly, slug, and annular flow.
- EO 1.33** **DESCRIBE** the problems associated with core flow oscillations and flow instability.
- EO 1.34** **DESCRIBE** the conditions that could lead to core flow oscillation and instability.
- EO 1.35** **DESCRIBE** the phenomenon of pipe whip.
- EO 1.36** **DESCRIBE** the phenomenon of water hammer.
-

Two-Phase Fluid Flow

All of the fluid flow relationships discussed previously are for the flow of a single phase of fluid whether liquid or vapor. At certain important locations in fluid flow systems the simultaneous flow of liquid water and steam occurs, known as *two-phase flow*. These simple relationships used for analyzing single-phase flow are insufficient for analyzing two-phase flow.

There are several techniques used to predict the head loss due to fluid friction for two-phase flow. Two-phase flow friction is greater than single-phase friction for the same conduit dimensions and mass flow rate. The difference appears to be a function of the type of flow and results from increased flow speeds. Two-phase friction losses are experimentally determined by measuring pressure drops across different piping elements. The two-phase losses are generally related to single-phase losses through the same elements.

One accepted technique for determining the two-phase friction loss based on the single-phase loss involves the two-phase friction multiplier (R), which is defined as the ratio of the two-phase head loss divided by the head loss evaluated using saturated liquid properties.

$$R = \frac{H_f, \text{ two-phase}}{H_f, \text{ saturated liquid}} \quad (3-18)$$

where:

R = two-phase friction multiplier (no units)

H_f , two-phase = two-phase head loss due to friction (ft)

H_f , saturated liquid = single-phase head loss due to friction (ft)

The friction multiplier (R) has been found to be much higher at lower pressures than at higher pressures. The two-phase head loss can be many times greater than the single-phase head loss.

Although a wide range of names has been used for two-phase flow patterns, we shall define only three types of flow. The flow patterns to be used are defined as follows:

1. Bubbly flow: there is dispersion of vapor bubbles in a continuum of liquid.
2. Slug flow: in bubbly flow, the bubbles grow by coalescence and ultimately become of the same order of diameter as the tube. This generates the typical bullet-shaped bubbles that are characteristic of the slug-flow regime.
3. Annular flow: the liquid is now distributed between a liquid film flowing up the wall and a dispersion of droplets flowing in the vapor core of the flow.

Flow Instability

Unstable flow can occur in the form of flow oscillations or flow reversals. *Flow oscillations* are variations in flow due to void formations or mechanical obstructions from design and manufacturing. A flow oscillation in one reactor coolant channel sometimes causes flow oscillations in the surrounding coolant channels due to flow redistribution. Flow oscillations are undesirable for several reasons. First, sustained flow oscillations can cause undesirable forced mechanical vibration of components. This can lead to failure of those components due to fatigue. Second, flow oscillations can cause system control problems of particular importance in liquid-cooled nuclear reactors because the coolant is also used as the moderator. Third, flow oscillations affect the local heat transfer characteristics and boiling. It has been found through testing that the critical heat flux (CHF) required for departure from nucleate boiling (DNB) can be lowered by as much as 40% when flow is oscillating. This severely reduces the thermal limit and the power density along the length of the reactor core. Again, it has been found through testing that flow oscillations are not a significant problem for some pressurized water reactors unless power is above 150% for the normal flow conditions. Flow oscillations can be a problem during natural circulation operations because of the low flow rates present.

During natural circulation, the steam bubbles formed during a flow oscillation may have enough of an effect to actually cause complete flow reversal in the affected channel.

Both the flow oscillations and flow reversals lead to a very unstable condition since the steam blankets formed on heated surfaces directly affect the ability to transfer heat away from those surfaces.

Pipe Whip

If a pipe were to rupture, the reaction force created by the high velocity fluid jet could cause the piping to displace and cause extensive damage to components, instrumentation, and equipment in the area of the rupture. This characteristic is similar to an unattended garden hose or fire hose "whipping" about unpredictably. This type of failure is analyzed to minimize damage if pipe whip were to occur in the vicinity of safety-related equipment.

Water Hammer

Water hammer is a liquid shock wave resulting from the sudden starting or stopping of flow. It is affected by the initial system pressure, the density of the fluid, the speed of sound in the fluid, the elasticity of the fluid and pipe, the change in velocity of the fluid, the diameter and thickness of the pipe, and the valve operating time.

During the closing of a valve, kinetic energy of the moving fluid is converted into potential energy. Elasticity of the fluid and pipe wall produces a wave of positive pressure back toward the fluid's source. When this wave reaches the source, the mass of fluid will be at rest, but under tremendous pressure. The compressed liquid and stretched pipe walls will now start to release the liquid in the pipe back to the source and return to the static pressure of the source. This release of energy will form another pressure wave back to the valve. When this shockwave reaches the valve, due to the momentum of the fluid, the pipe wall will begin to contract. This contraction is transmitted back to the source, which places the pressure in the piping below that of the static pressure of the source. These pressure waves will travel back and forth several times until the fluid friction dampens the alternating pressure waves to the static pressure of the source. Normally, the entire hammer process takes place in under one second.

The initial shock of suddenly stopped flow can induce transient pressure changes that exceed the static pressure. If the valve is closed slowly, the loss of kinetic energy is gradual. If it is closed quickly, the loss of kinetic energy is very rapid. A shock wave results because of this rapid loss of kinetic energy. The shock wave caused by water hammer can be of sufficient magnitude to cause physical damage to piping, equipment, and personnel. Water hammer in pipes has been known to pull pipe supports from their mounts, rupture piping, and cause pipe whip.

Pressure Spike

A *pressure spike* is the resulting rapid rise in pressure above static pressure caused by water hammer. The highest pressure spike attained will be at the instant the flow changed and is governed by the following equation.

$$\Delta P = \frac{\rho_c \Delta v}{g_c}$$

where:

$$\Delta P = \text{Pressure spike} \left(\frac{\text{lbf}}{\text{ft}^2} \right)$$

$$\rho = \text{Density of the fluid} \left(\frac{\text{lbf}}{\text{ft}^3} \right)$$

$$c = \text{Velocity of the pressure wave} \\ \text{(Speed of sound in the fluid)} \left(\frac{\text{ft}}{\text{sec}} \right)$$

$$\Delta v = \text{Change in velocity of the fluid} \left(\frac{\text{ft}}{\text{sec}} \right)$$

$$g_c = \text{Gravitational constant } 32.17 \left(\frac{\text{lbf-ft}}{\text{lbf-sec}^2} \right)$$

Example: Pressure spike

Water at a density of 62.4 lbf/ft³ and a pressure of 120 psi is flowing through a pipe at 10 ft/sec. The speed of sound in the water is 4780 ft/sec. A check valve suddenly closed. What is the maximum pressure of the fluid in psi?

Solution:

$$P_{\text{Max}} = P_{\text{Static}} + \Delta P_{\text{Spike}}$$

$$P_{\text{Max}} = 120 \frac{\text{lbf}}{\text{in}^2} + \frac{\rho_c \Delta V}{g_c}$$

$$P_{\text{Max}} = 120 \frac{\text{lbf}}{\text{in}^2} + \frac{62.4 \frac{\text{lbf}}{\text{ft}^3} \cdot 4780 \frac{\text{ft}}{\text{sec}} \cdot 10 \frac{\text{ft}}{\text{sec}}}{32.17 \frac{\text{lbf ft}}{\text{lbf sec}^2}}$$

$$P_{\text{Max}} = 120 \frac{\text{lbf}}{\text{in}^2} + 92,631 \frac{\text{lbf}}{\text{ft}^2} \left(\frac{\text{ft}^2}{144 \text{ in}^2} \right)$$

$$P_{\text{Max}} = 120 \frac{\text{lbf}}{\text{in}^2} + 643.3 \frac{\text{lbf}}{\text{in}^2}$$

$$P_{\text{Max}} = 763.3 \text{ psi}$$

Steam Hammer

Steam hammer is similar to water hammer except it is for a steam system. *Steam hammer* is a gaseous shock wave resulting from the sudden starting or stopping of flow. Steam hammer is not as severe as water hammer for three reasons:

1. The compressibility of the steam dampens the shock wave
2. The speed of sound in steam is approximately one third the speed of sound in water.
3. The density of steam is approximately 1600 times less than that of water.

The items of concern that deal with steam piping are thermal shock and water slugs (i.e., condensation in the steam system) as a result of improper warm up.

Operational Considerations

Water and steam hammer are not uncommon occurrences in industrial plants. Flow changes in piping systems should be done slowly as part of good operator practice. To prevent water and steam hammer, operators should ensure liquid systems are properly vented and ensure gaseous or steam systems are properly drained during start-up. When possible, initiate pump starts against a closed discharge valve, and open the discharge valve slowly to initiate system flow. If possible, start-up smaller capacity pumps before larger capacity pumps. Use warm-up valves around main stream stop valves whenever possible. If possible, close pump discharge valves before stopping pumps. Periodically verify proper function of moisture traps and air traps during operation.

Summary

The main points from this chapter are summarized below.

Two-Phase Fluid Flow Summary

- The combination of liquid and vapor flowing through a pipe is called two-phase flow.
- Types of two-phase flow include:
 - Bubbly flow: there is a dispersion of vapor bubbles in a continuum of liquid.
 - Slug flow: the bubbles grow by coalescence and ultimately become of the same order of diameter as the tube, generating bullet shaped bubbles.
 - Annular flow: the liquid is distributed between a liquid film flowing up the wall and a dispersion of droplets flowing in the vapor core of the flow.
- Core flow oscillations and instabilities can cause:
 - undesirable mechanical vibration of components.
 - a reduction in the heat flux required to cause DNB.
 - interruptions to actual circulation flow.
- Flow oscillations and instabilities can occur during the following conditions:
 - core is outside design conditions, power > 150%
 - mechanical failure, causing flow blockage
 - inadequate core cooling during natural circulation, such that boiling is occurring
- Pipe whip is the displacement of piping created by the reaction forces of a high velocity fluid jet following a pipe rupture.
- Water hammer is a liquid shock wave resulting from a sudden starting or stopping of flow.

CENTRIFUGAL PUMPS

Centrifugal pumps are one of the most common components found in fluid systems. In order to understand how a fluid system containing a centrifugal pump operates, it is necessary to understand the head and flow relationships for a centrifugal pump.

- EO 1.37** **DEFINE** the terms net positive suction head and cavitation.
- EO 1.38** **CALCULATE** the new volumetric flow rate, head, or power for a variable speed centrifugal pump using the pump laws.
- EO 1.39** **DESCRIBE** the effect on system flow and pump head for the following changes:
- a. Changing pump speeds
 - b. Adding pumps in parallel
 - c. Adding pumps in series
-

Energy Conversion in a Centrifugal Pump

Fluid entering a centrifugal pump is immediately directed to the low pressure area at the center or eye of the impeller. As the impeller and blading rotate, they transfer momentum to incoming fluid. A transfer of momentum to the moving fluid increases the fluid's velocity. As the fluid's velocity increases its kinetic energy increases. Fluid of high kinetic energy is forced out of the impeller area and enters the volute.

The volute is a region of continuously increasing cross-sectional area designed to convert the kinetic energy of the fluid into fluid pressure. The mechanism of this energy conversion is the same as that for subsonic flow through the diverging section of a nozzle. The mathematical analysis of flow through the volute is based on the general energy equation, the continuity equation, and the equation relating the internal properties of a system. The key parameters influencing the energy conversion are the expanding cross-sectional area of the volute, the higher system back pressure at the discharge of the volute, and the incompressible, subsonic flow of the fluid. As a result of the interdependence of these parameters, the fluid flow in the volute, similar to subsonic flow in a diverging nozzle, experiences a velocity decrease and a pressure increase.

Operating Characteristics of a Centrifugal Pump

Normally, a centrifugal pump produces a relatively low pressure increase in the fluid. This pressure increase can be anywhere from several dozen to several hundred psid across a centrifugal pump with a single stage impeller. The term PSID (**P**ounds **F**orce **P**er **S**quare **I**nch **D**ifferential) is equivalent to ΔP . In this context, it is the pressure difference between the suction and discharge of a pump. PSID can also be used to describe a pressure drop across a system component (strainers, filters, heat exchangers, valves, demineralizers, etc.). When a centrifugal pump is operating at a constant speed, an increase in the system back pressure on the flowing stream causes a reduction in the magnitude of volumetric flow rate that the centrifugal pump can maintain.

Analysis of the relationship between the volumetric flow rate (\dot{V}) that a centrifugal pump can maintain and the pressure differential across the pump (ΔP_{pump}) is based on various physical characteristics of the pump and the system fluid. Variables evaluated by design engineers to determine this relationship include the pump efficiency, the power supplied to the pump, the rotational speed, the diameter of the impeller and blading, the fluid density, and the fluid viscosity. The result of this complicated analysis for a typical centrifugal pump operating at one particular speed is illustrated by the graph in Figure 7.

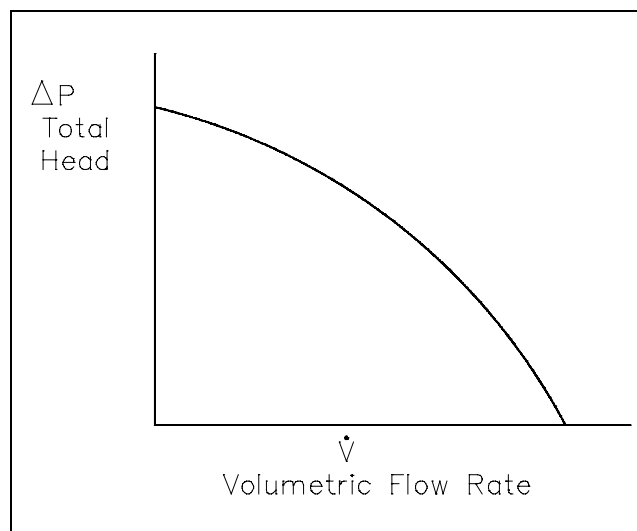

Figure 7 Typical Centrifugal Pump Characteristic Curve

Pump head, on the vertical axis, is the difference between system back pressure and the inlet pressure of the pump (ΔP_{pump}). Volumetric flow rate (\dot{V}), on the horizontal axis, is the rate at which fluid is flowing through the pump. The graph assumes one particular speed (N) for the pump impeller.

Cavitation

When the liquid being pumped enters the eye of a centrifugal pump, the pressure is significantly reduced. The greater the flow velocity through the pump the greater this pressure drop. If the pressure drop is great enough, or if the temperature of the liquid is high enough, the pressure drop may be sufficient to cause the liquid to flash to steam when the local pressure falls below the saturation pressure for the fluid that is being pumped. These vapor bubbles are swept along the pump impeller with the fluid. As the flow velocity decreases the fluid pressure increases. This causes the vapor bubbles to suddenly collapse on the outer portions of the impeller. The formation of these vapor bubbles and their subsequent collapse is *cavitation*.

Cavitation can be a very serious problem for centrifugal pumps. Some pumps can be designed to operate with limited amounts of cavitation. Most centrifugal pumps cannot withstand cavitation for significant periods of time; they are damaged by erosion of the impeller, vibration, or some other cavitation-induced problem.

Net Positive Suction Head

It is possible to ensure that cavitation is avoided during pump operation by monitoring the net positive suction head of the pump. *Net positive suction head* (NPSH) for a pump is the difference between the suction pressure and the saturation pressure of the fluid being pumped. NPSH is used to measure how close a fluid is to saturated conditions. Equation 3-19 can be used to calculate the net positive suction head available for a pump. The units of NPSH are feet of water.

$$\text{NPSH} = P_{\text{suction}} - P_{\text{saturation}} \quad (3-19)$$

where:

$$\begin{aligned} P_{\text{suction}} &= \text{suction pressure of the pump} \\ P_{\text{saturation}} &= \text{saturation pressure for the fluid} \end{aligned}$$

By maintaining the available NPSH at a level greater than the NPSH required by the pump manufacturer, cavitation can be avoided.

Pump Laws

Centrifugal pumps generally obey what are known as the pump laws. These laws state that the flow rate or capacity is directly proportional to the pump speed; the discharge head is directly proportional to the square of the pump speed; and the power required by the pump motor is directly proportional to the cube of the pump speed. These laws are summarized in the following equations.

$$\dot{V} \propto n \quad (3-20)$$

$$H_p \propto n^2 \quad (3-21)$$

$$p \propto n^3 \quad (3-22)$$

where:

n = speed of pump impeller (rpm)

\dot{V} = volumetric flow rate of pump (gpm or ft³/hr)

H_p = head developed by pump (psid or feet)

p = pump power (kW)

Using these proportionalities, it is possible to develop equations relating the condition at one speed to those at a different speed.

$$\dot{V}_1 \left(\frac{n_2}{n_1} \right) = \dot{V}_2 \quad (3-23)$$

$$H_{p_1} \left(\frac{n_2}{n_1} \right)^2 = H_{p_2} \quad (3-24)$$

$$p_1 \left(\frac{n_2}{n_1} \right)^3 = p_2 \quad (3-25)$$

Example: Pump Laws

A cooling water pump is operating at a speed of 1800 rpm. Its flow rate is 400 gpm at a head of 48 ft. The power of the pump is 45 kW. Determine the pump flow rate, head, and power requirements if the pump speed is increased to 3600 rpm.

Solution:

Flow rate

$$\begin{aligned} \dot{V}_2 &= \dot{V}_1 \left(\frac{n_2}{n_1} \right) \\ &= (400 \text{ gpm}) \left(\frac{3600 \text{ rpm}}{1800 \text{ rpm}} \right) \\ &= 800 \text{ gpm} \end{aligned}$$

Head

$$\begin{aligned}H_{P_2} &= H_{P_1} \left(\frac{n_2}{n_1} \right)^2 \\ &= 48 \text{ ft} \left(\frac{3600 \text{ rpm}}{1800 \text{ rpm}} \right)^2 \\ &= 192 \text{ ft}\end{aligned}$$

Power

$$\begin{aligned}P_2 &= P_1 \left(\frac{n_2}{n_1} \right)^3 \\ &= 45 \text{ kW} \left(\frac{3600 \text{ rpm}}{1800 \text{ rpm}} \right)^3 \\ &= 360 \text{ kW}\end{aligned}$$

It is possible to develop the characteristic curve for the new speed of a pump based on the curve for its original speed. The technique is to take several points on the original curve and apply the pump laws to determine the new head and flow at the new speed. The pump head versus flow rate curve that results from a change in pump speed is graphically illustrated in Figure 8.

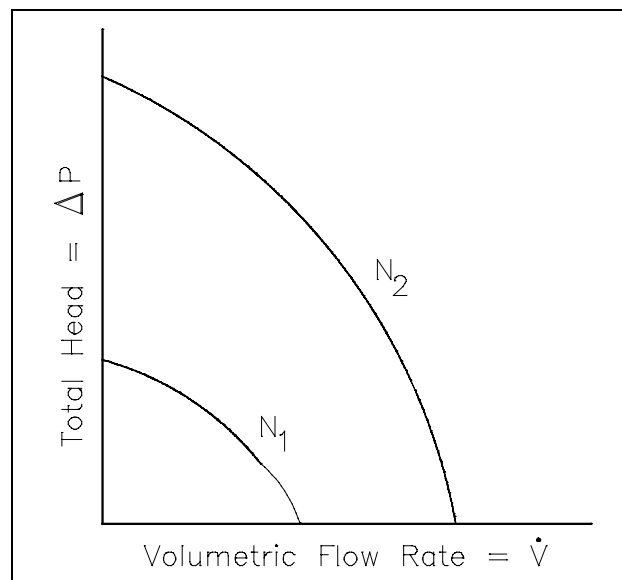

Figure 8 Changing Speeds for Centrifugal Pump

System Characteristic Curve

In the chapter on head loss, it was determined that both frictional losses and minor losses in piping systems were proportional to the square of the flow velocity. Since flow velocity is directly proportional to the volumetric flow rate, the system head loss must be directly proportional to the square of the volumetric flow rate. From this relationship, it is possible to develop a curve of system head loss versus volumetric flow rate. The head loss curve for a typical piping system is in the shape of a parabola as shown in Figure 9.

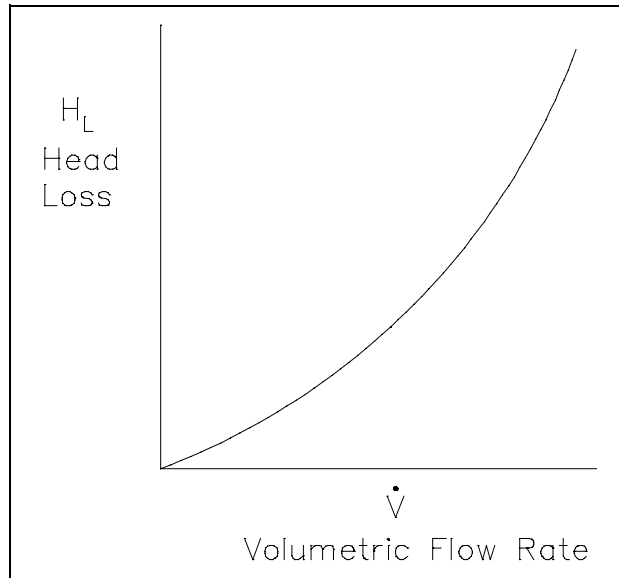

Figure 9 Typical System Head Loss Curve

System Operating Point

The point at which a pump operates in a given piping system depends on the flow rate and head loss of that system. For a given system, volumetric flow rate is compared to system head loss on a system characteristic curve. By graphing a system characteristic curve and the pump characteristic curve on the same coordinate system, the point at which the pump must operate is identified. For example, in Figure 10, the operating point for the centrifugal pump in the original system is designated by the intersection of the pump curve and the system curve (h_{L_0}).

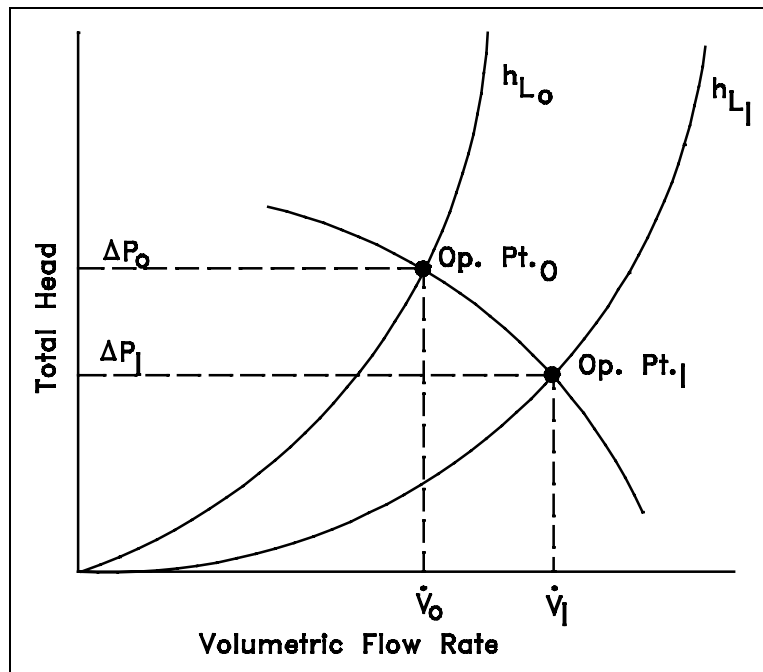

Figure 10 Operating Point for a Centrifugal Pump

The system has a flow rate equal to \dot{V}_0 and a total system head loss equal to ΔP_0 . In order to maintain the flow rate (\dot{V}_0), the pump head must be equal to ΔP_0 . In the system described by the system curve (h_{L1}), a valve has been opened in the system to reduce the system's resistance to flow. For this system, the pump maintains a large flow rate (\dot{V}_1) at a smaller pump head (ΔP_1).

System Use of Multiple Centrifugal Pumps

A typical centrifugal pump has a relatively low number of moving parts and can be easily adapted to a variety of prime movers. These prime movers include AC and DC electric motors, diesel engines, steam turbines, and air motors. Centrifugal pumps are typically small in size and can usually be built for a relatively low cost. In addition, centrifugal pumps provide a high volumetric flow rate with a relatively low pressure.

In order to increase the volumetric flow rate in a system or to compensate for large flow resistances, centrifugal pumps are often used in parallel or in series. Figure 11 depicts two identical centrifugal pumps operating at the same speed in parallel.

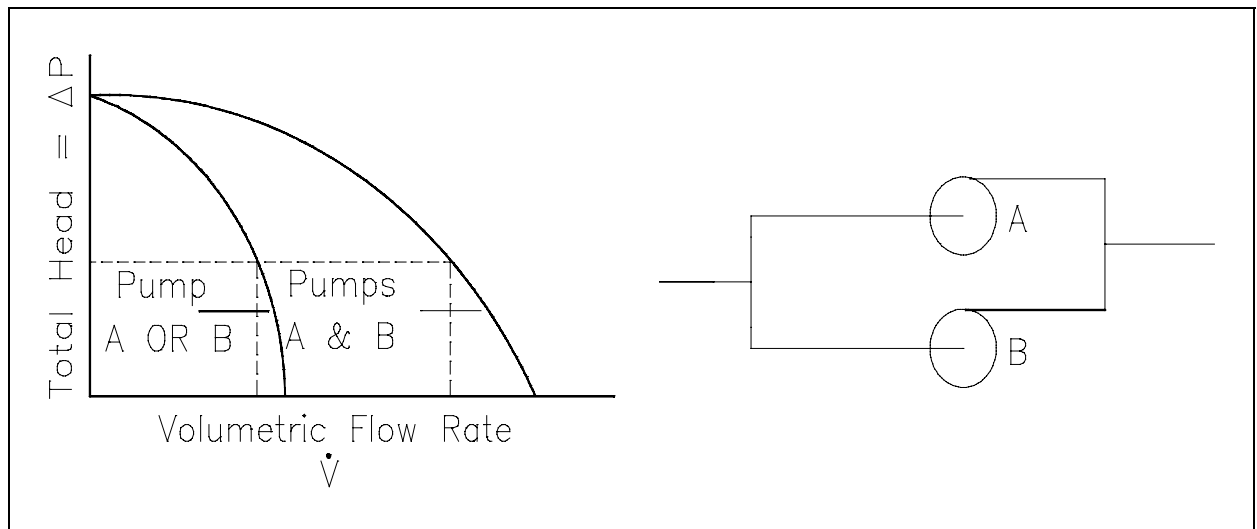

Figure 11 Pump Characteristic Curve for Two Identical Centrifugal Pumps Used in Parallel

Centrifugal Pumps in Parallel

Since the inlet and the outlet of each pump shown in Figure 11 are at identical points in the system, each pump must produce the same pump head. The total flow rate in the system, however, is the sum of the individual flow rates for each pump.

When the system characteristic curve is considered with the curve for pumps in parallel, the operating point at the intersection of the two curves represents a higher volumetric flow rate than for a single pump and a greater system head loss. As shown in Figure 12, a greater system head loss occurs with the increased fluid velocity resulting from the increased volumetric flow rate. Because of the greater system head, the volumetric flow rate is actually less than twice the flow rate achieved by using a single pump.

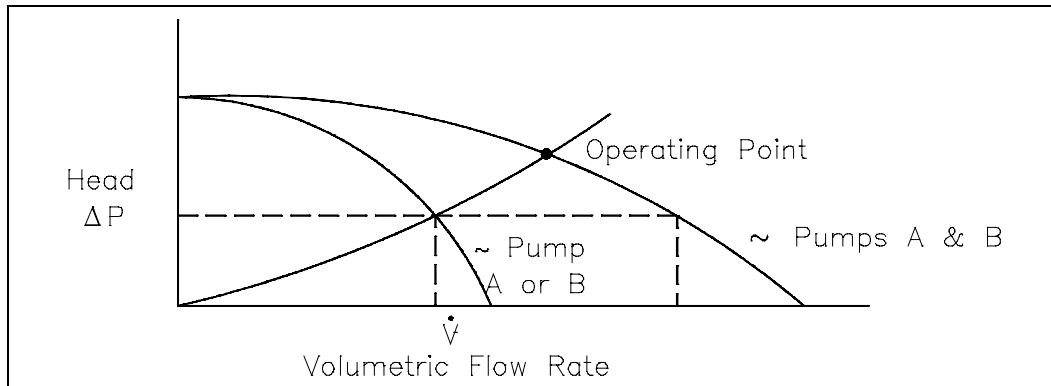

Figure 12 Operating Point for Two Parallel Centrifugal Pumps

Centrifugal Pumps in Series

Centrifugal pumps are used in series to overcome a larger system head loss than one pump can compensate for individually. As illustrated in Figure 13, two identical centrifugal pumps operating at the same speed with the same volumetric flow rate contribute the same pump head. Since the inlet to the second pump is the outlet of the first pump, the head produced by both pumps is the sum of the individual heads. The volumetric flow rate from the inlet of the first pump to the outlet of the second remains the same.

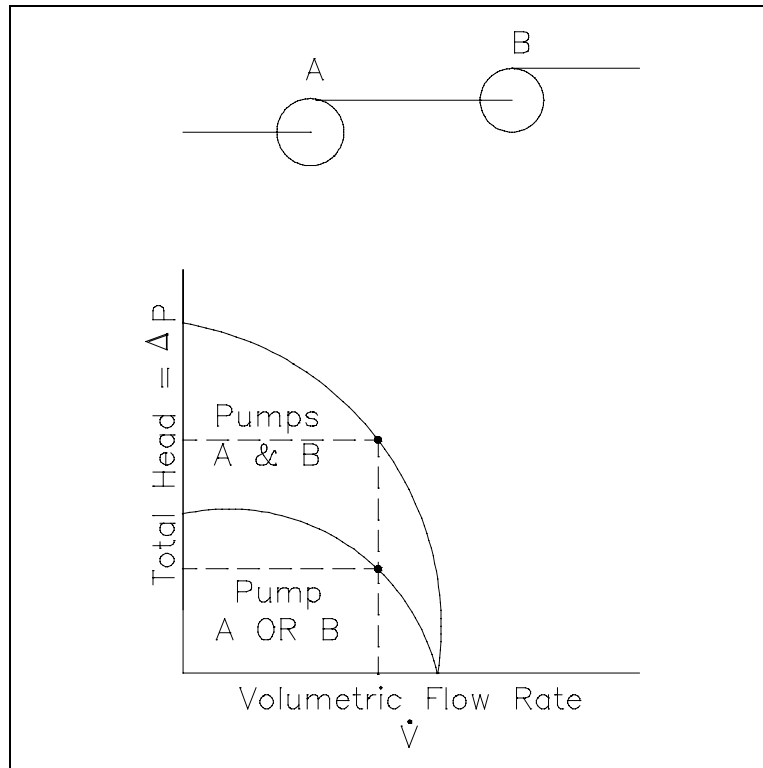

Figure 13 Pump Characteristic Curve for Two Identical Centrifugal Pumps Used in Series

As shown in Figure 14, using two pumps in series does not actually double the resistance to flow in the system. The two pumps provide adequate pump head for the new system and also maintain a slightly higher volumetric flow rate.

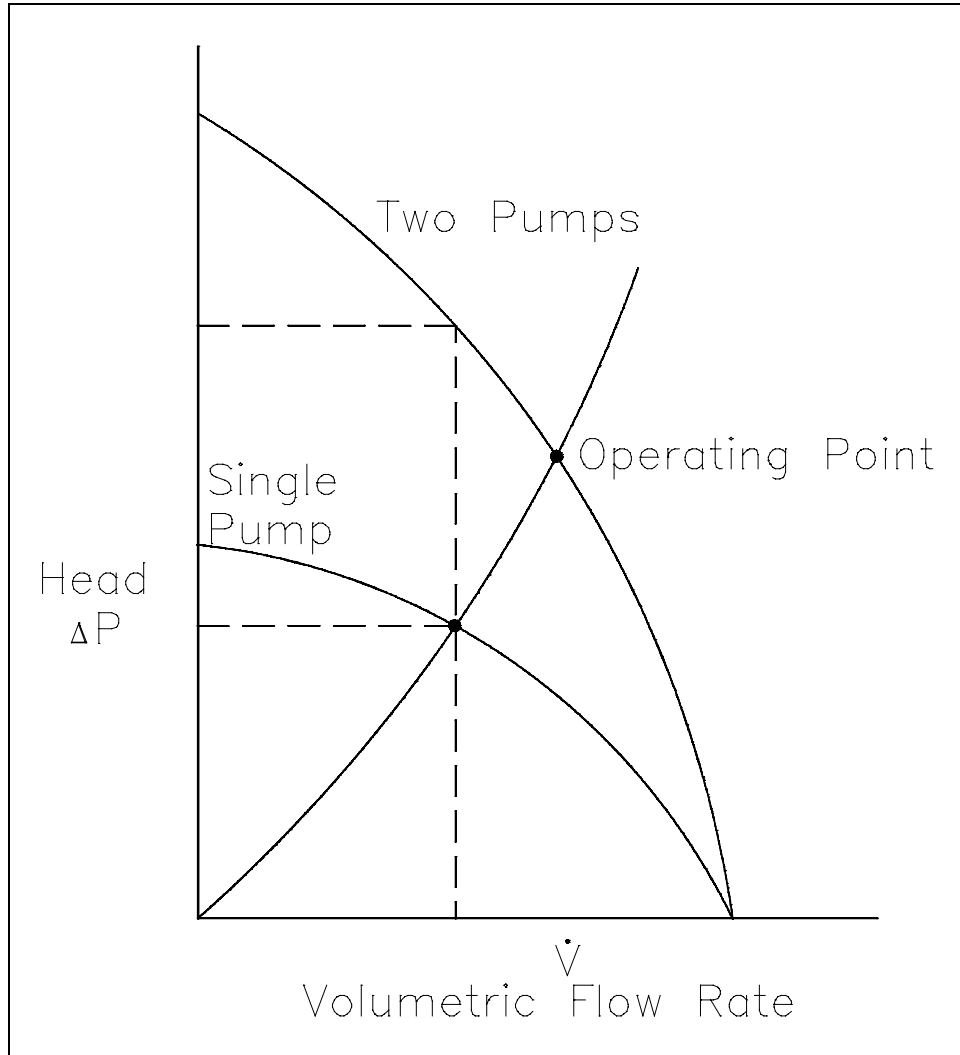

Figure 14 Operating Point for Two Centrifugal Pumps in Series

Summary

The main points from this chapter are summarized below.

Centrifugal Pumps Summary

- Net positive suction head is the difference between the pump suction pressure and the saturation pressure for the fluid.
- Cavitation is the formation and subsequent collapse of vapor bubbles on the impeller of a pump as the local pressure falls below and then rises above the saturation pressure of the fluid being pumped.
- The pump laws can be used to determine the effect of varying the speed of a centrifugal pump on the flow, head, and power.

$$\dot{V}_1 \left(\frac{n_2}{n_1} \right) = \dot{V}_2$$

$$H_{P_1} \left(\frac{n_2}{n_1} \right)^2 = H_{P_2}$$

$$P_1 \left(\frac{n_2}{n_1} \right)^3 = P_2$$

- The combined pump curve for two centrifugal pumps in parallel can be determined by adding the individual flows for any given head.
- The combined pump curve for two centrifugal pumps in series can be determined by adding the individual heads for any given flow.
- The operating point (head and flow) of a system can be determined by plotting the pump curve and the system head loss curve on the same axes. The system will operate at the intersection of the two curves.

Appendix B
Fluid Flow

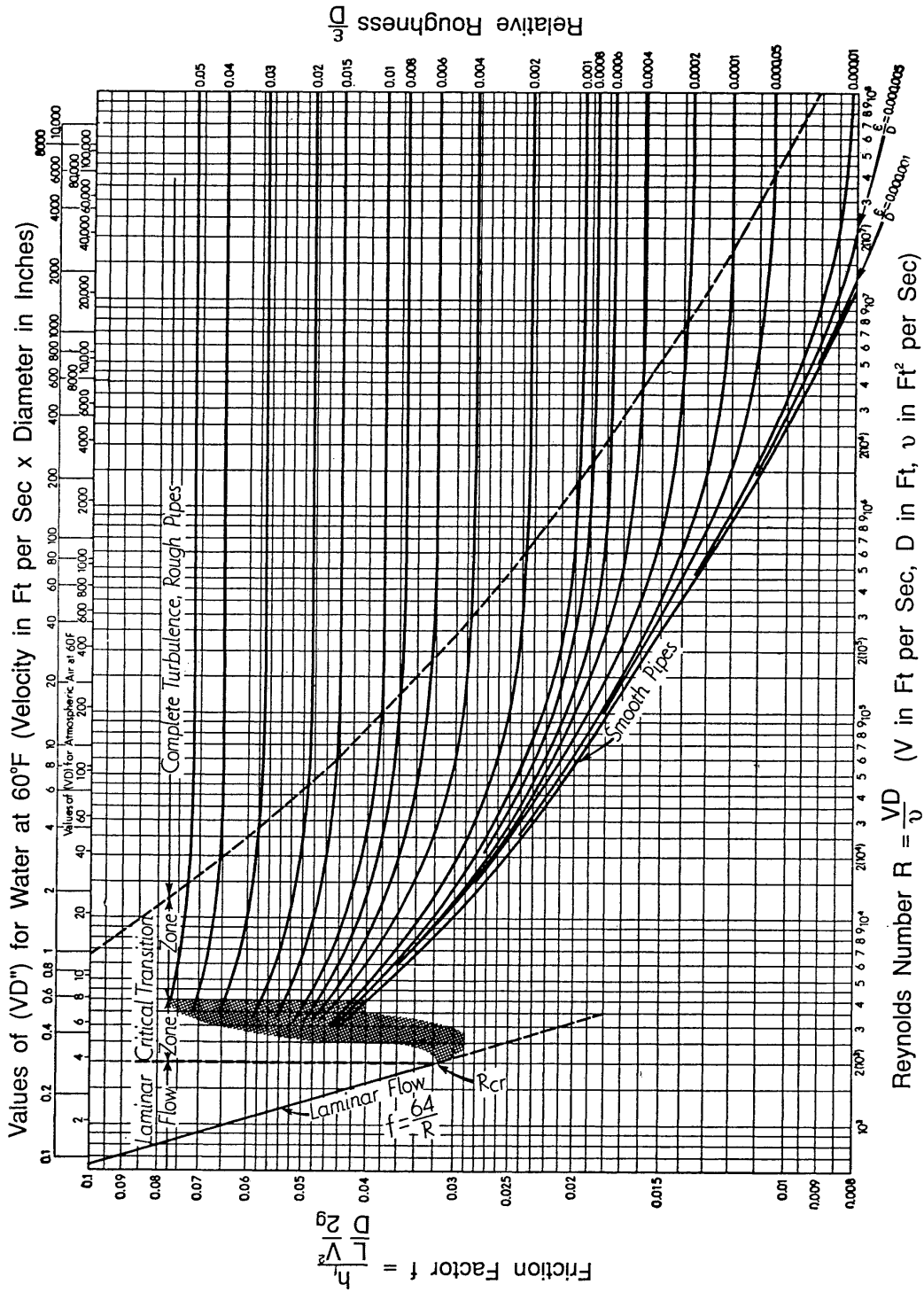

Figure B-1 Moody Chart

end of text.

CONCLUDING MATERIAL

Review activities:

Preparing activity:

DOE - ANL-W, BNL, EG&G Idaho,
EG&G Mound, EG&G Rocky Flats,
LLNL, LANL, MMES, ORAU, REEC_o,
WHC, WINCO, WEMCO, and WSRC.

DOE - NE-73
Project Number 6910-0018/3