



Design Of Sheet Pile Walls

Course Number: ST-02-340

PDH: 10

Approved for: AK, AL, AR, FL, GA, IA, IL, IN, KS, KY, LA, MD, ME, MI, MN, MO, MS, MT, NC, ND, NE, NH, NJ, NM, NV, NY, OH, OK, OR, PA, SC, SD, TN, TX, UT, VA, VT, WI, WV, and WY

New Jersey Professional Competency Approval #24GP00025600

North Carolina Approved Sponsor #S-0695

Maryland Approved Provider of Continuing Professional Competency

Indiana Continuing Education Provider #CE21800088

Florida Provider #0009553 License #868

NYSED Sponsor #274

This document is the course text. You may review this material at your leisure before or after you purchase the course. In order to obtain credit for this course, complete the following steps:

- 1) Log in to My Account and purchase the course. If you don't have an account, go to New User to create an account.
- 2) After the course has been purchased, review the technical material and then complete the quiz at your convenience.
- 3) A Certificate of Completion is available once you pass the exam (70% or greater). If a passing grade is not obtained, you may take the quiz as many times as necessary until a passing grade is obtained (up to one year from the purchase date).

If you have any questions or technical difficulties, please call (508) 298-4787 or email us at admin@PDH-Pro.com.

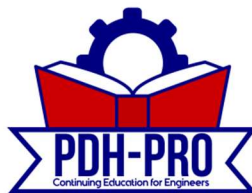

| | | |
|---|---|----------------|
| CECW-ED Engineer Manual 1110-2-2504 | Department of the Army U.S. Army Corps of Engineers Washington, DC 20314-1000 | EM 1110-2-2504 |
| | Engineering and Design DESIGN OF SHEET PILE WALLS | |
| | Distribution Restriction Statement Approved for public release; distribution is unlimited. | |

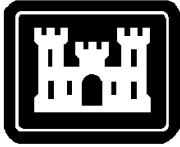

**US Army Corps
of Engineers**

ENGINEERING AND DESIGN

Design of Sheet Pile Walls

ENGINEER MANUAL

CECW-ED

Manual
No. 1110-2-2504

Engineering and Design
DESIGN OF SHEET PILE WALLS

1. Purpose. This manual provides information on foundation exploration and testing procedures, analysis techniques, allowable criteria, design procedures, and construction consideration for the selection, design, and installation of sheet pile walls. The guidance is based on the present state of the technology for sheet pile-soil-structure interaction behavior. This manual provides design guidance intended specifically for the geotechnical and structural engineer. It also provides essential information for others interested in sheet pile walls such as the construction engineer in understanding construction techniques related to sheet pile wall behavior during installation. Since the understanding of the physical causes of sheet pile wall behavior is actively expanding by better definition through ongoing research, prototype, model sheet pile wall testing and development of more refined analytical models, this manual is intended to provide examples and procedures of what has been proven successful. This is not the last nor final word on the state of the art for this technology. We expect, as further practical design and installation procedures are developed from the expansion of this technology, that these updates will be issued as changes to this manual.

2. Applicability. This manual applies to all HQUSACE elements, major subordinate commands, districts, laboratories, and field operating activities having civil works responsibilities, especially those geotechnical and structural engineers charged with the responsibility for design and installation of safe and economical sheet pile walls used as retaining walls or floodwalls.

FOR THE COMMANDER:



WILLIAM D. BROWN
Colonel, Corps of Engineers
Chief of Staff

CECW-ED

Manual
No. 1110-2-2504

**Engineering and Design
DESIGN OF SHEET PILE WALLS**

Table of Contents

| Subject | Paragraph | Page | Subject | Paragraph | Page |
|---|-----------|------|--|-----------|------|
| Chapter 1 | | | | | |
| Introduction | | | | | |
| Purpose | 1-1 | 1-1 | Earth Pressures | 4-2 | 4-1 |
| Applicability | 1-2 | 1-1 | Earth Pressure Calculations | 4-3 | 4-3 |
| References, Bibliographical and Related Material | 1-3 | 1-1 | Surcharge Loads | 4-4 | 4-5 |
| Scope | 1-4 | 1-1 | Water Loads | 4-5 | 4-6 |
| Definitions | 1-5 | 1-1 | Additional Applied Loads | 4-6 | 4-6 |
| Chapter 2 | | | Chapter 5 | | |
| General Considerations | | | System Stability | | |
| Coordination | 2-1 | 2-1 | Modes of Failure | 5-1 | 5-1 |
| Alignment Selection | 2-2 | 2-1 | Design for Rotational Stability | 5-2 | 5-1 |
| Geotechnical Considerations | 2-3 | 2-2 | Chapter 6 | | |
| Structural Considerations | 2-4 | 2-2 | Structural Design | | |
| Construction | 2-5 | 2-3 | Forces for Design | 6-1 | 6-1 |
| Postconstruction Architectural Treatment and Landscaping | 2-6 | 2-8 | Deflections | 6-2 | 6-1 |
| Chapter 3 | | | Design of Sheet Piling | 6-3 | 6-1 |
| Geotechnical Investigation | | | Chapter 7 | | |
| Planning the Investigation | 3-1 | 3-1 | Soil-Structure Interaction Analysis | | |
| Subsurface Exploration and Site Characterization | 3-2 | 3-1 | Introduction | 7-1 | 7-1 |
| Testing of Foundation Materials | 3-3 | 3-1 | Soil-Structure Interaction Method | 7-2 | 7-1 |
| In Situ Testing of Foundation Materials | 3-4 | 3-5 | Preliminary Information | 7-3 | 7-1 |
| Design Strength Selection | 3-5 | 3-8 | SSI Model | 7-4 | 7-1 |
| Chapter 4 | | | Nonlinear Soil Springs | 7-5 | 7-1 |
| System Loads | | | Nonlinear Anchor Springs | 7-6 | 7-3 |
| General | 4-1 | 4-1 | Application of SSI Analysis | 7-7 | 7-4 |
| Chapter 8 | | | Chapter 8 | | |
| | | | Engineering Considerations for Construction | | |
| | | | General | 8-1 | 8-1 |
| | | | Site Conditions | 8-2 | 8-1 |

| Subject | Paragraph | Page | Subject | Paragraph | Page |
|--|-----------|------|--|-----------|------|
| Construction Sequence | 8-3 | 8-1 | Corrosion | 9-2 | 9-1 |
| Earthwork | 8-4 | 8-1 | Liquefaction Potential During | | |
| Equipment and Accessories | 8-5 | 8-1 | Driving | 9-3 | 9-1 |
| Storage and Handling | 8-6 | 8-2 | Settlement | 9-4 | 9-2 |
| Methods of Installation | 8-7 | 8-2 | Transition Sections | 9-5 | 9-3 |
| Driveability of Sheet Piling | 8-8 | 8-2 | Utility Crossings | 9-6 | 9-8 |
| Tolerances | 8-9 | 8-3 | Periodic Inspections | 9-7 | 9-8 |
| Anchors | 8-10 | 8-3 | Maintenance and Rehabilitation | 9-8 | 9-8 |
| | | | Instrumentation | 9-9 | 9-8 |
| Chapter 9 | | | Appendix A | | |
| Special Design Considerations | | | References | | |
| I-Walls of Varying Thickness | 9-1 | 9-1 | | | |

Chapter 1 Introduction

1-1. Purpose

The purpose of this manual is to provide guidance for the safe design and economical construction of sheet pile retaining walls and floodwalls. This manual does not prohibit the use of other methods of analysis that maintain the same degree of safety and economy as structures designed by the methods outlined herein.

1-2. Applicability

This manual applies to all HQUSACE elements, major subordinate commands, districts, laboratories, and field operating activities (FOA) having civil works responsibilities.

1-3. References, Bibliographical and Related Material

a. References pertaining to this manual are listed in Appendix A. Additional reference materials pertaining to the subject matter addressed in this manual are also included in Appendix A.

b. Several computer programs are available to assist in applying some of the analytical functions described in this manual.

(1) CWALSHT - Performs many of the classical design and analysis techniques for determining required depth of penetration and/or factor of safety and includes application of Rowe's Moment Reduction for anchored walls. (CORPS Program X0031)

(2) CWALSSI - Performs soil-structure interaction analysis of cantilever or anchored walls (Dawkins 1992).

1-4. Scope

Design guidance provided herein is intended to apply to wall/soil systems of traditional heights and configurations in an essentially static loading environment. Where a system is likely to be required to withstand the effects of an earthquake as a part of its design function, the design should follow the processes and conform to the requirements of "A Manual for Seismic Design of Waterfront Retaining Structures" (U.S. Army Engineer

Waterways Experiment Station (USAEWES) in preparation).

1-5. Definitions

The following terms and definitions are used herein.

a. Sheet pile wall: A row of interlocking, vertical pile segments driven to form an essentially straight wall whose plan dimension is sufficiently large that its behavior may be based on a typical unit (usually 1 foot) vertical slice.

b. Cantilever wall: A sheet pile wall which derives its support solely through interaction with the surrounding soil.

c. Anchored wall: A sheet pile wall which derives its support from a combination of interaction with the surrounding soil and one (or more) mechanical devices which inhibit motion at an isolated point(s). The design procedures described in this manual are limited to a single level of anchorage.

d. Retaining wall: A sheet pile wall (cantilever or anchored) which sustains a difference in soil surface elevation from one side to the other. The change in soil surface elevations may be produced by excavation, dredging, backfilling, or a combination.

e. Floodwall: A cantilevered sheet pile wall whose primary function is to sustain a difference in water elevation from one side to the other. In concept, a floodwall is the same as a cantilevered retaining wall. A sheet pile wall may be a floodwall in one loading condition and a retaining wall in another.

f. I-wall: A special case of a cantilevered wall consisting of sheet piling in the embedded depth and a monolithic concrete wall in the exposed height.

g. Dredge side: A generic term referring to the side of a retaining wall with the lower soil surface elevation or to the side of a floodwall with the lower water elevation.

h. Retained side: A generic term referring to the side of a retaining wall with the higher soil surface elevation or to the side of a floodwall with the higher water elevation.

i. Dredge line: A generic term applied to the soil surface on the dredge side of a retaining or floodwall.

j. Wall height: The length of the sheet piling above the dredge line.

k. Backfill: A generic term applied to the material on the retained side of the wall.

l. Foundation: A generic term applied to the soil on either side of the wall below the elevation of the dredge line.

m. Anchorage: A mechanical assemblage consisting of wales, tie rods, and anchors which supplement soil support for an anchored wall.

(1) Single anchored wall: Anchors are attached to the wall at only one elevation.

(2) Multiple anchored wall: Anchors are attached to the wall at more than one elevation.

n. Anchor force: The reaction force (usually expressed per foot of wall) which the anchor must provide to the wall.

o. Anchor: A device or structure which, by interacting with the soil or rock, generates the required anchor force.

p. Tie rods: Parallel bars or tendons which transfer the anchor force from the anchor to the wales.

q. Wales: Horizontal beam(s) attached to the wall to transfer the anchor force from the tie rods to the sheet piling.

r. Passive pressure: The limiting pressure between the wall and soil produced when the relative wall/soil motion tends to compress the soil horizontally.

s. Active pressure: The limiting pressure between the wall and soil produced when the relative wall/soil motion tends to allow the soil to expand horizontally.

t. At-rest pressure: The horizontal in situ earth pressure when no horizontal deformation of the soil occurs.

u. Penetration: The depth to which the sheet piling is driven below the dredge line.

v. Classical design procedures: A process for evaluating the soil pressures, required penetration, and design forces for cantilever or single anchored walls assuming limiting states in the wall/soil system.

w. Factor of safety:

(1) Factor of safety for rotational failure of the entire wall/soil system (mass overturning) is the ratio of available resisting effort to driving effort.

(2) Factor of safety (strength reduction factor) applied to soil strength parameters for assessing limiting soil pressures in Classical Design Procedures.

(3) Structural material factor of safety is the ratio of limiting stress (usually yield stress) for the material to the calculated stress.

x. Soil-structure interaction: A process for analyzing wall/soil systems in which compatibility of soil pressures and structural displacements are enforced.

Chapter 2 General Considerations

2-1. Coordination

The coordination effort required for design and construction of a sheet pile wall is dependent on the type and location of the project. Coordination and cooperation among hydraulic, geotechnical, and structural engineers must be continuous from the inception of the project to final placement in operation. At the beginning, these engineering disciplines must consider alternative wall types and alignments to identify real estate requirements. Other disciplines must review the proposed project to determine its effect on existing facilities and the environment. Close coordination and consultation of the design engineers and local interests must be maintained throughout the design and construction process since local interests share the cost of the project and are responsible for acquiring rights-of-way, accomplishing relocations, and operating and maintaining the completed project. The project site should be subjected to visual inspection by all concerned groups throughout the implementation of the project from design through construction to placement in operation.

2-2. Alignment Selection

The alignment of a sheet pile wall may depend on its function. Such situations include those in harbor or port construction where the alignment is dictated by the water source or where the wall serves as a tie-in to primary structures such as locks, dams, etc. In urban or industrial areas, it will be necessary to consider several alternative alignments which must be closely coordinated with local interests. In other circumstances, the alignment may be dependent on the configuration of the system such as space requirements for an anchored wall or the necessary right-of-way for a floodwall/levee system. The final alignment must meet the general requirements of providing the most viable compromise between economy and minimal environmental impact.

a. Obstructions. Site inspections in the planning phase should identify any obstructions which interfere with alternative alignments or which may necessitate special construction procedures. These site inspections should be supplemented by information obtained from local agencies to locate underground utilities such as sewers, water lines, power lines, and telephone lines. Removal or relocation of any obstruction must be

coordinated with the owner and the local assuring agency. Undiscovered obstructions will likely result in construction delays and additional costs for removal or relocation of the obstruction. Contracts for construction in congested areas may include a requirement for the contractor to provide an inspection trench to precede pile driving.

b. Impacts on the surrounding area. Construction of a wall can have a severe permanent and/or temporary impact on its immediate vicinity. Permanent impacts may include modification, removal, or relocation of existing structures. Alignments which require permanent relocation of residences or businesses require additional lead times for implementation and are seldom cost effective. Particular consideration must be given to sheet pile walls constructed as flood protection along waterfronts. Commercial operations between the sheet pile wall and the waterfront will be negatively affected during periods of high water and, in addition, gated openings through the wall must be provided for access. Temporary impacts of construction can be mitigated to some extent by careful choice of construction strategies and by placing restrictions on construction operations. The effects of pile driving on existing structures should be carefully considered.

c. Rights-of-way. In some cases, particularly for flood protection, rights-of-way may already be dedicated. Every effort should be made to maintain the alignment of permanent construction within the dedicated right-of-way. Procurement of new rights-of-way should begin in the feasibility stage of wall design and should be coordinated with realty specialists and local interests. Temporary servitudes for construction purposes should be determined and delineated in the contract documents. When possible, rights-of-way should be marked with permanent monuments.

d. Surveys. All points of intersection in the alignment and all openings in the wall should be staked in the field for projects in congested areas. The field survey is usually made during the detailed design phase. The field survey may be required during the feasibility phase if suitability of the alignment is questionable. The field survey should identify any overhead obstructions, particularly power lines, to ensure sufficient vertical clearance to accommodate pile driving and construction operations. Information on obstruction heights and clearances should be verified with the owners of the items.

2-3. Geotechnical Considerations

Because sheet pile walls derive their support from the surrounding soil, an investigation of the foundation materials along the wall alignment should be conducted at the inception of the planning for the wall. This investigation should be a cooperative effort among the structural and geotechnical engineers and should include an engineering geologist familiar with the area. All existing data bases should be reviewed. The goals of the initial geotechnical survey should be to identify any poor foundation conditions which might render a wall not feasible or require revision of the wall alignment, to identify subsurface conditions which would impede pile driving, and to plan more detailed exploration required to define design parameters of the system. Geotechnical investigation requirements are discussed in detail in Chapter 3 of this EM.

2-4. Structural Considerations

a. Wall type. The selection of the type of wall, anchored or cantilever, must be based on the function of the wall, the characteristics of the foundation soils, and the proximity of the wall to existing structures.

(1) Cantilever walls. Cantilever walls are usually used as floodwall or as earth retaining walls with low wall heights (10 to 15 feet or less). Because cantilever walls derive their support solely from the foundation soils, they may be installed in relatively close proximity (but not less than 1.5 times the overall length of the piling) to existing structures. Typical cantilever wall configurations are shown in Figure 2-1.

(2) Anchored walls. An anchored wall is required when the height of the wall exceeds the height suitable for a cantilever or when lateral deflections are a consideration. The proximity of an anchored wall to an existing structure is governed by the horizontal distance required for installation of the anchor (Chapter 5). Typical configurations of anchored wall systems are shown in Figure 2-2.

b. Materials. The designer must consider the possibility of material deterioration and its effect on the structural integrity of the system. Most permanent structures are constructed of steel or concrete. Concrete is capable of providing a long service life under normal circumstances but has relatively high initial costs when compared to steel sheet piling. They are more difficult to install than steel piling. Long-term field observations indicate that steel sheet piling provides a long service

life when properly designed. Permanent installations should allow for subsequent installation of cathodic protection should excessive corrosion occur.

(1) Heavy-gauge steel. Steel is the most common material used for sheet pile walls due to its inherent strength, relative light weight, and long service life. These piles consist of interlocking sheets manufactured by either a hot-rolled or cold-formed process and conform to the requirements of the American Society for Testing and Materials (ASTM) Standards A 328 (ASTM 1989a), A 572 (ASTM 1988), or A 690 (ASTM 1989b). Piling conforming to A 328 are suitable for most installations. Steel sheet piles are available in a variety of standard cross sections. The Z-type piling is predominantly used in retaining and floodwall applications where bending strength governs the design. When interlock tension is the primary consideration for design, an arched or straight web piling should be used. Turns in the wall alignment can be made with standard bent or fabricated corners. The use of steel sheet piling should be considered for any sheet pile structure. Typical configurations are shown in Figure 2-3.

(2) Light-gauge steel. Light-gauge steel piling are shallow-depth sections, cold formed to a constant thickness of less than 0.25 inch and manufactured in accordance with ASTM A 857 (1989c). Yield strength is dependent on the gauge thickness and varies between 25 and 36 kips per square inch (ksi). These sections have low-section moduli and very low moments of inertia in comparison to heavy-gauge Z-sections. Specialized coatings such as hot dip galvanized, zinc plated, and aluminized steel are available for improved corrosion resistance. Light-gauge piling should be considered for temporary or minor structures. Light-gauge piling can be considered for permanent construction when accompanied by a detailed corrosion investigation. Field tests should minimally include PH and resistivity measurements. See Figure 2-4 for typical light-gauge sections.

(3) Wood. Wood sheet pile walls can be constructed of independent or tongue-and-groove interlocking wood sheets. This type of piling should be restricted to short-to-moderate wall heights and used only for temporary structures. See Figure 2-5 for typical wood sections.

(4) Concrete. These piles are precast sheets 6 to 12 inches deep, 30 to 48 inches wide, and provided with tongue-and-groove or grouted joints. The grouted-type joint is cleaned and grouted after driving to provide a reasonably watertight wall. A bevel across the pile bottom, in the direction of pile progress, forces one pile

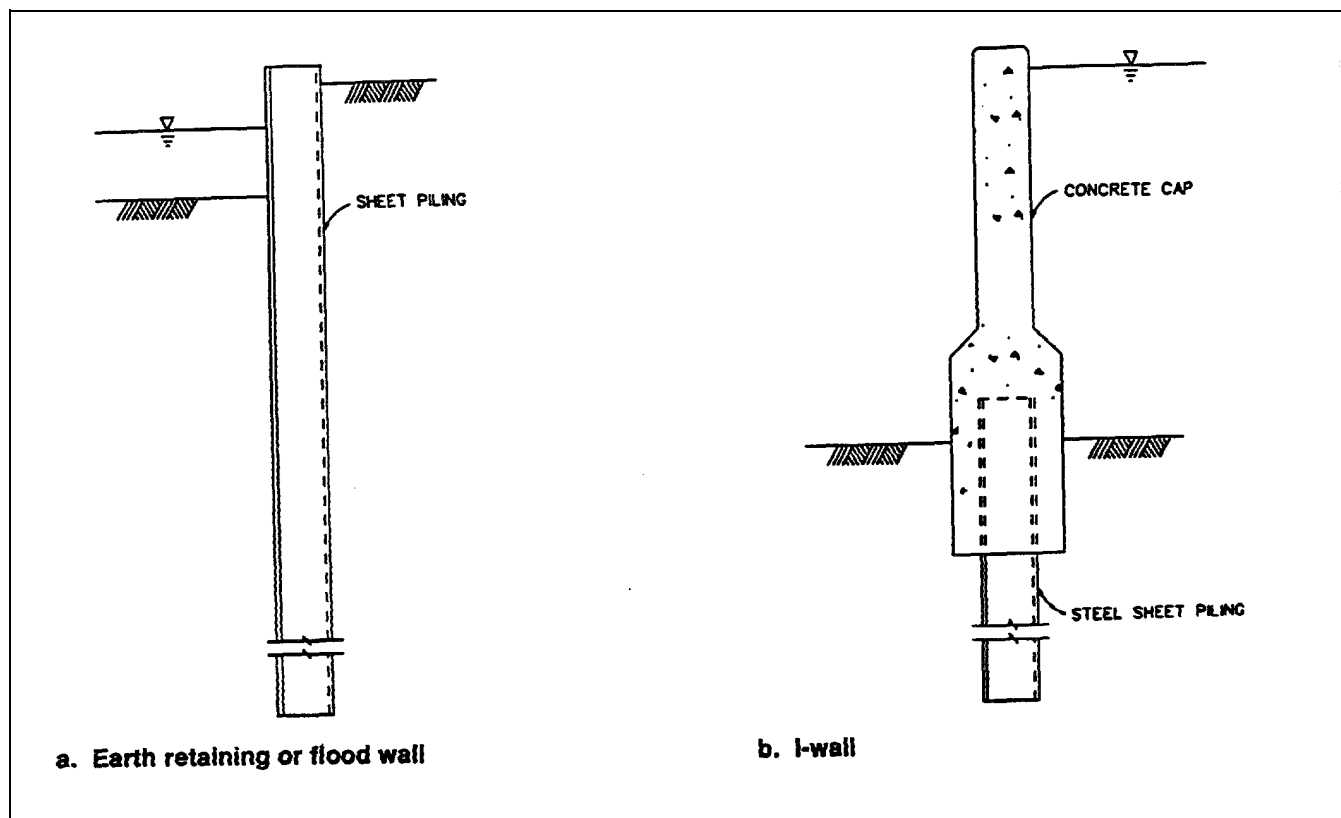

Figure 2-1. Typical cantilevered walls

against the other during installation. Concrete sheet piles are usually prestressed to facilitate handling and driving. Special corner and angle sections are typically made from reinforced concrete due to the limited number required. Concrete sheet piling can be advantageous for marine environments, streambeds with high abrasion, and where the sheet pile must support significant axial load. Past experience indicates this pile can induce settlement (due to its own weight) in soft foundation materials. In this case the watertightness of the wall will probably be lost. Typical concrete sections are shown in Figure 2-6. This type of piling may not be readily available in all localities.

(5) Light-gauge aluminum. Aluminum sheet piling is available as interlocking corrugated sheets, 20 to 4 inches deep, 0.10 to 0.188 inch thick, and made from aluminum alloy 5052 or 6061. These sections have a relatively low-section modulus and moment of inertia necessitating tiebacks for most situations. A Z-type section is also available in a depth of 6 inches and a thickness of up to 0.25 inch. Aluminum sections should be considered for shoreline erosion projects and low

bulkheads exposed to salt or brackish water when embedment will be in free-draining granular material. See Figure 2-7 for typical sections.

(6) Other materials. Pilings made from special materials such as vinyl, polyvinyl chloride, and fiberglass are also available. These pilings have low structural capacities and are normally used in tie-back situations. Available lengths of piling are short when compared to other materials. Material properties must be obtained from the manufacturer and must be carefully evaluated by the designer for each application.

2-5. Construction

Instructions to the field are necessary to convey to field personnel the intent of the design. A report should be prepared by the designer and should minimally include the following:

a. Design assumptions regarding interpretation of subsurface and field investigations.

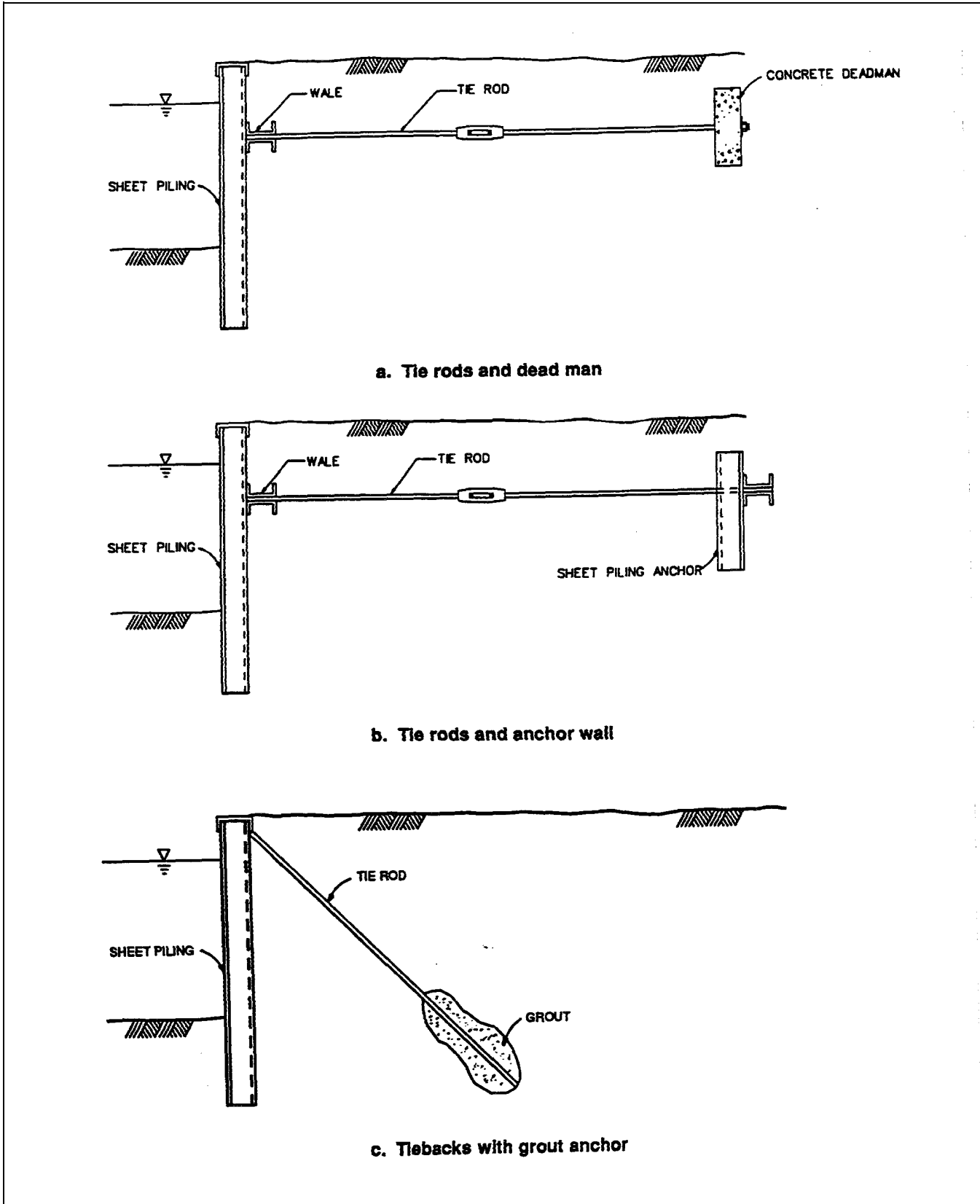

Figure 2-2. Anchored walls (Continued)

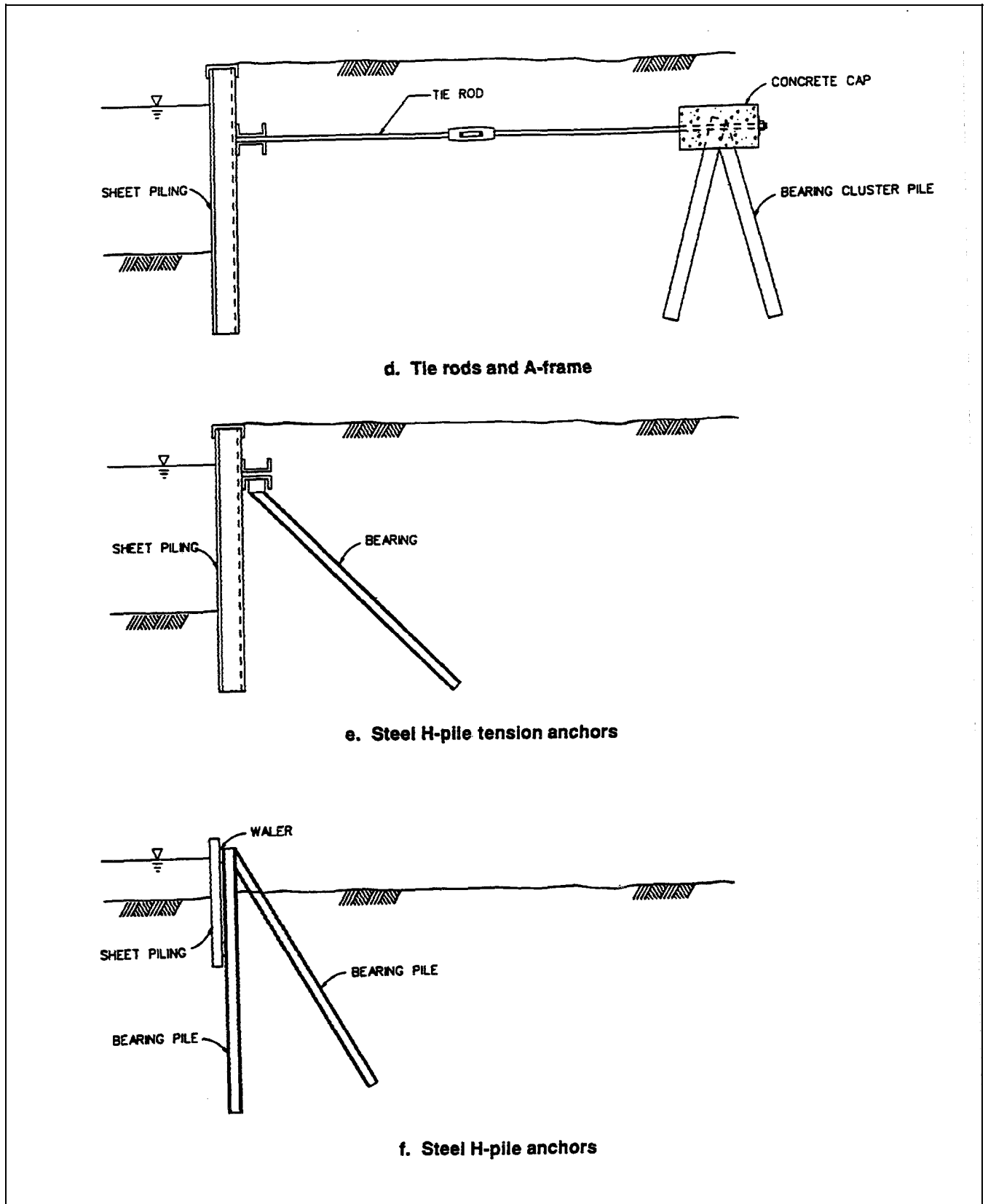

Figure 2-2. (Concluded)

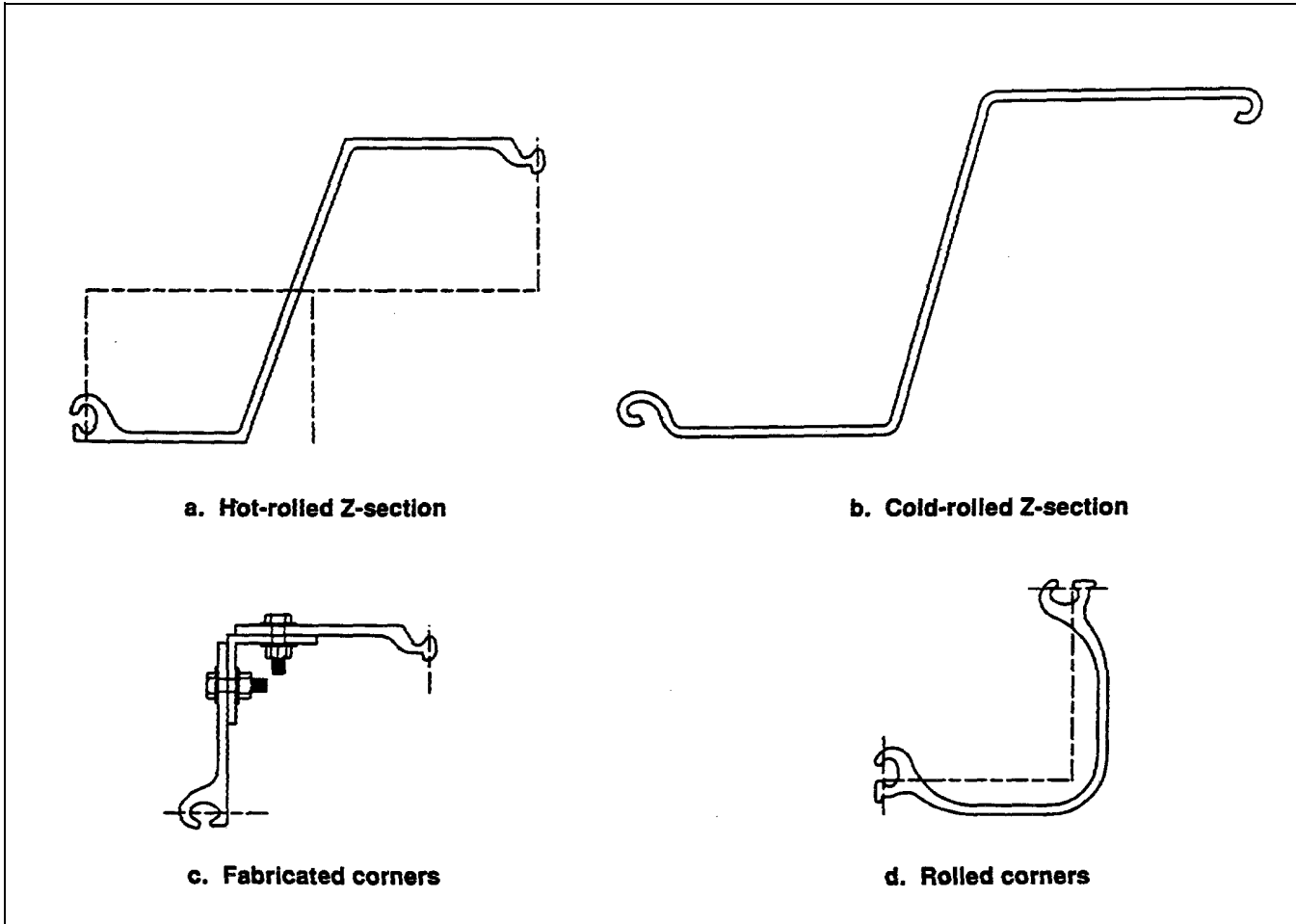

Figure 2-3. Typical heavy-gauge steel piling

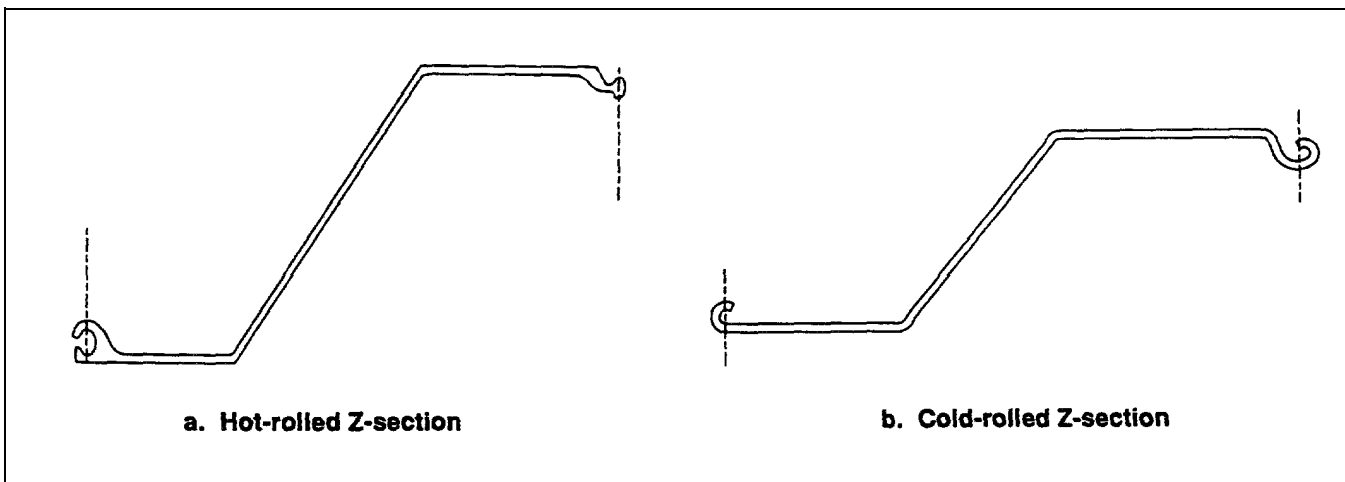

Figure 2-4. Typical light-gauge steel piling

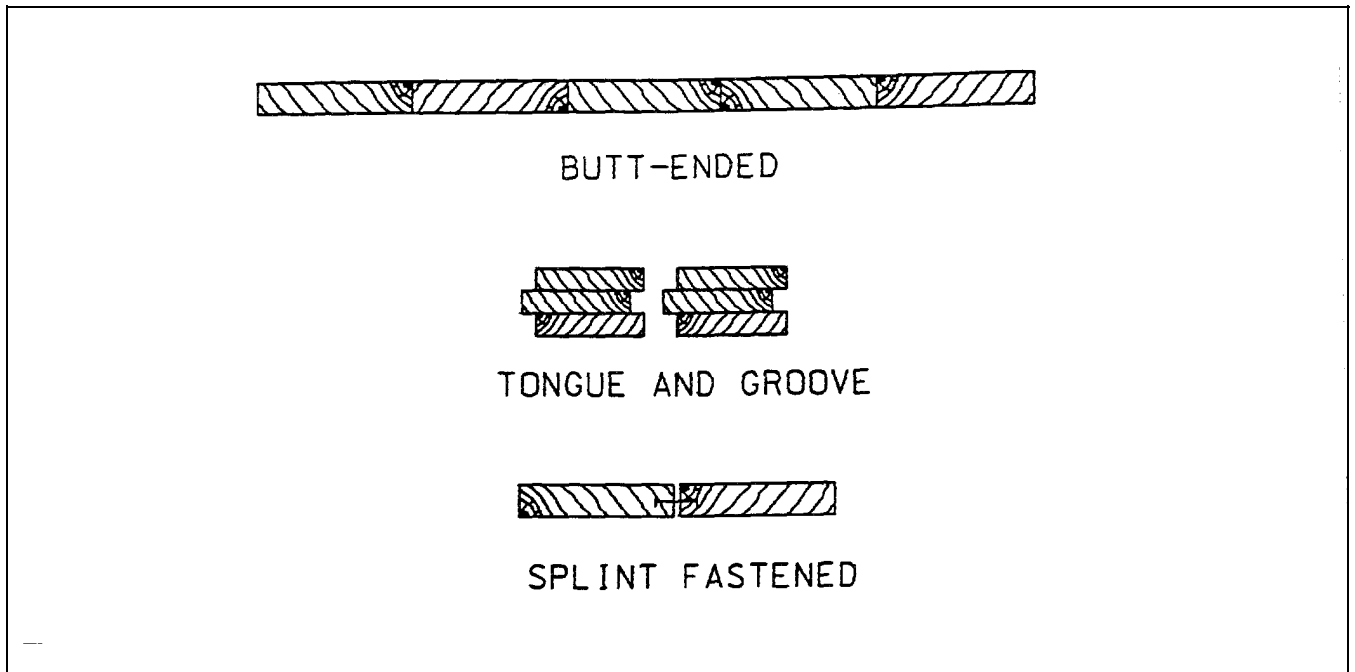

Figure 2-5. Typical wood sections

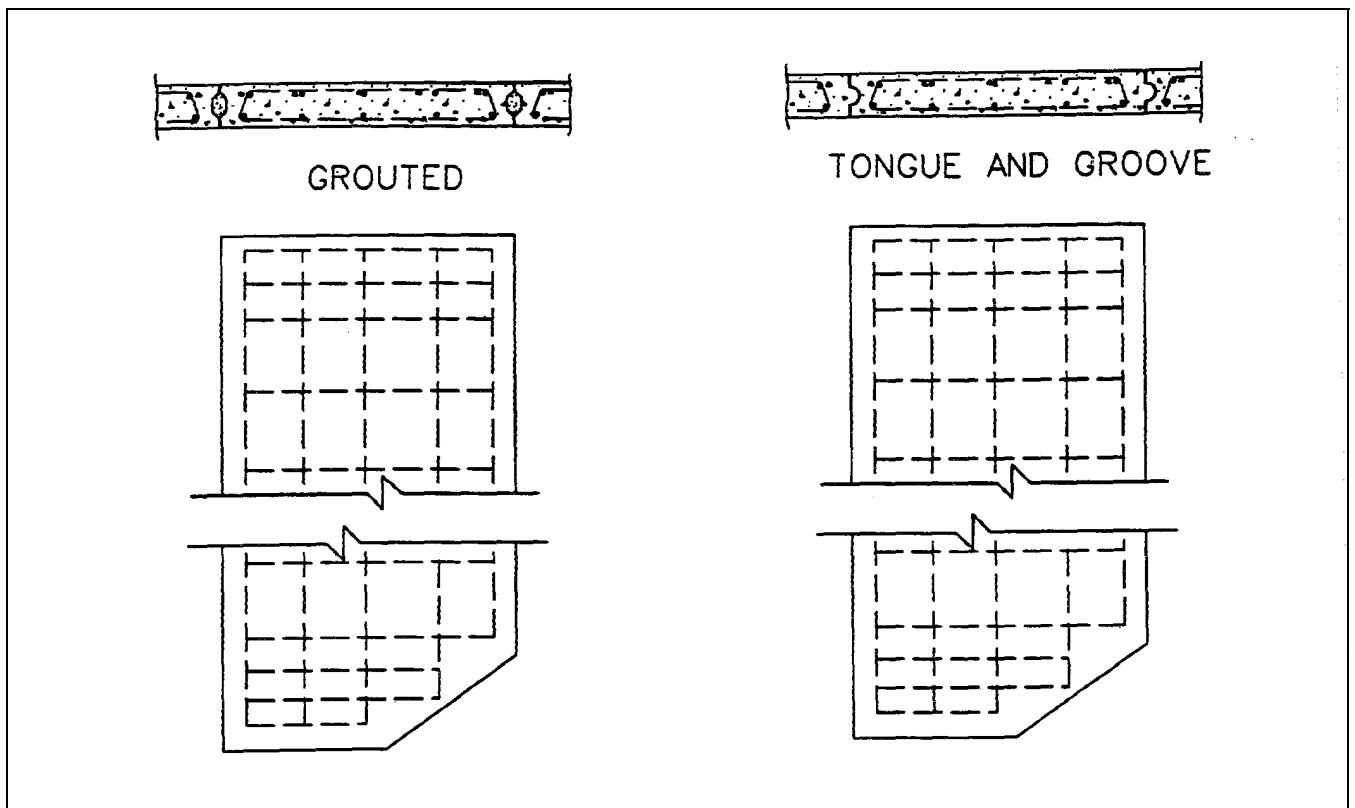

Figure 2-6. Typical concrete sections

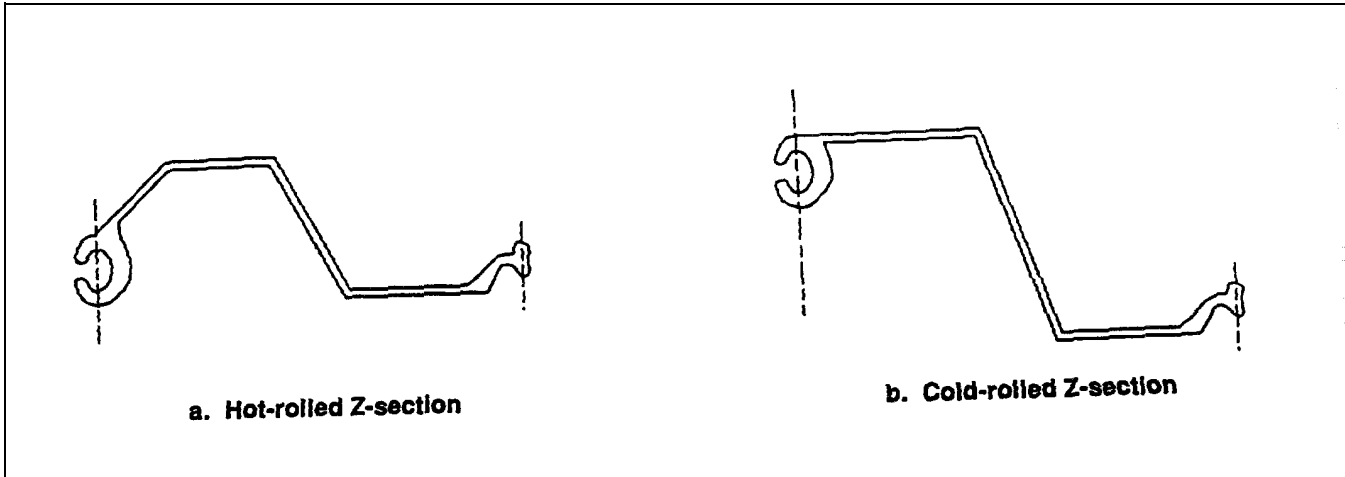

Figure 2-7. Typical aluminum sheet piling

b. Explanation of the concepts, assumptions, and special details of the design.

c. Assistance for field personnel in interpreting the plans and specifications.

d. Indication to field personnel of critical areas in the design which require additional control and inspection.

2-6. Postconstruction Architectural Treatment and Landscaping

Retaining walls and floodwalls can be esthetically enhanced with architectural treatments to the concrete and landscaping (references EM 1110-1-2009 and EM 1110-2-301, respectively). This is strongly recommended in urbanized areas.

Chapter 3 Geotechnical Investigation

3-1. Planning the Investigation

a. Purpose. The purpose of the geotechnical investigation for wall design is to identify the type and distribution of foundation materials, to identify sources and characteristics of backfill materials, and to determine material parameters for use in design/analyses. Specifically, the information obtained will be used to select the type and depth of wall, design the sheet pile wall system, estimate earth pressures, locate the ground-water level, estimate settlements, and identify possible construction problems. For flood walls, foundation underseepage conditions must also be assessed. Detailed information regarding subsurface exploration techniques may be found in EM 1110-1-1804 and EM 1110-2-1907.

b. Review of existing information. The first step in an investigational program is to review existing data so that the program can be tailored to confirm and extend the existing knowledge of subsurface conditions. EM 1110-1-1804 provides a detailed listing of possible data sources; important sources include aerial photographs, geologic maps, surficial soil maps, and logs from previous borings. In the case of floodwalls, study of old topographic maps can provide information on past riverbank or shore geometry and identify likely fill areas.

c. Coordination. The geotechnical investigation program should be laid out by a geotechnical engineer familiar with the project and the design of sheet pile walls. The exploration program should be coordinated with an engineering geologist and/or geologist familiar with the geology of the area.

3-2. Subsurface Exploration and Site Characterization

a. Reconnaissance phase and feasibility phase exploration: Where possible, exploration programs should be accomplished in phases so that information obtained in each phase may be used advantageously in planning later phases. The results of each phase are used to "characterize" the site deposits for analysis and design by developing idealized material profiles and assigning material properties. For long, linear structures like floodwalls, geophysical methods such as seismic and resistivity techniques often provide an ability to

rapidly define general conditions at modest cost. In alluvial flood plains, aerial photograph studies can often locate recent channel filling or other potential problem areas. A moderate number of borings should be obtained at the same time to refine the site characterization and to "calibrate" geophysical findings. Borings should extend deep enough to sample any materials which may affect wall performance; a depth of five times the exposed wall height below the ground surface can be considered a minimum "rule of thumb." For floodwalls atop a levee, the exploration program must be sufficient not only to evaluate and design the sheet pile wall system but also assess the stability of the overall levee system. For floodwalls where underseepage is of concern, a sufficient number of the borings should extend deep enough to establish the thickness of any pervious strata. The spacing of borings depends on the geology of the area and may vary from site to site. Boring spacing should be selected to intersect distinct geological characteristics of the project.

b. Preconstruction engineering and design phase. During this phase, explorations are conducted to develop detailed material profiles and quantification of material parameters. The number of borings should typically be two to five times the number of preliminary borings. No exact spacing is recommended, as the boring layout should be controlled by the geologic conditions and the characteristics of the proposed structure. Based on the preliminary site characterization, borings should be situated to confirm the location of significant changes in subsurface conditions as well as to confirm the continuity of apparently consistent subsurface conditions. At this time, undisturbed samples should be obtained for laboratory testing and/or in situ tests should be performed.

c. Construction general phase. In some cases, additional exploration phases may be useful to resolve questions arising during detailed design to provide more detailed information to bidders in the plans and specifications, subsequent to construction, or to support claims and modifications.

3-3. Testing of Foundation Materials

a. General. Procedures for testing soils are described in EM 1110-2-1906. Procedures for testing rock specimens are described in the *Rock Testing Handbook* (U.S. Army Engineer Waterways Experiment Station (WES) 1980). Much of the discussion on use of laboratory tests in EM 1110-1-1804 and EM 1110-2-1913 also applies to sheet pile wall design.

Classification and index tests (water content, Atterberg limits, grain size) should be performed on most or all samples and shear tests should be performed on selected representative undisturbed samples. Where settlement of fine-grain foundation materials is of concern, consolidation tests should also be performed. The strength parameters ϕ and c are not intrinsic material properties but rather are parameters that depend on the applied stresses, the degree of consolidation under those stresses, and the drainage conditions during shear. Consequently, their values must be based on laboratory tests that appropriately model these conditions as expected in the field.

b. Coarse-grain materials (cohesionless). Coarse-grain materials such as sands, gravels, and nonplastic silts are sufficiently pervious that excess pore pressures do not develop when stress conditions are changed. Their shear strength is characterized by the angle of internal friction (ϕ) determined from consolidated, drained (S or CD) tests. Failure envelopes plotted in terms of total or effective stresses are the same, and typically exhibit a zero c value and a ϕ value in the range of 25 to 45 degrees. The value of ϕ for coarse-grain soils varies depending predominately on the particle shape, gradation, and relative density. Because of the difficulty of obtaining undisturbed samples of coarse-grain soils, the ϕ value is usually inferred from in situ tests or conservatively assumed based on material type.

(1) Table 3-1 shows approximate relationships between the relative density, standard penetration resistance (SPT), angle of internal friction, and unit weight of granular soils. Figure 3-1 shows another correlation between ϕ , relative density, and unit weight for various types of coarse-grain soils. Where site-specific correlations are desired for important structures, laboratory tests may be performed on samples recompacted to simulate field density.

(2) The wall friction angle, δ , is usually expressed as a fraction of the angle of internal friction, ϕ . Table 3-2 shows the smallest ratios between δ and ϕ determined in an extensive series of tests by Potyondy (1961). Table 3-3 shows angle of wall friction for various soils against steel and concrete sheet pile walls.

c. Fine-grain materials (cohesive soils). The shear strength of fine-grain materials, such as clays and plastic silts, is considerably more complex than coarse-grain soils because of their significantly lower permeability,

higher void ratios, and the interaction between the pore water and the soil particles.

(1) Fine-grain soils subjected to stress changes develop excess (either positive or negative) pore pressures because their low permeability precludes an instantaneous water content change, an apparent $\phi = 0$ condition in terms of total stresses. Thus, their behavior is time dependent due to their low permeability, resulting in different behavior under short-term (undrained) and long-term (drained) loading conditions. The condition of $\phi = 0$ occurs only in normally consolidated soils. Overconsolidated clays "remember" the past effective stress and exhibit the shear strength corresponding to a stress level closer to the preconsolidation pressure rather than the current stress; at higher stresses, above the preconsolidation pressure, they behave like normally consolidated clays.

(2) The second factor, higher void ratio, generally means lower shear strength (and more difficult designs). But in addition, it creates other problems. In some (sensitive) clays the loose structure of the clay may be disturbed by construction operations leading to a much lower strength and even a liquid state.

(3) The third factor, the interaction between clay particles and water (at microscopic scale), is the main cause of the "different" behavior of clays. The first two factors, in fact, can be attributed to this (Lambe and Whitman 1969). Other aspects of "peculiar" clay behavior, such as sensitivity, swelling (expansive soils), and low, effective- ϕ angles are also explainable by this factor.

(4) In practice, the overall effects of these factors are indirectly expressed with the index properties such as LL (liquid limit), PL (plastic limit), w (water content), and e (void ratio). A high LL or PL in a soil is indicative of a more "clay-like" or "plastic" behavior. In general, if the natural water content, w , is closer to PL , the clay may be expected to be stiff, overconsolidated, and have a high undrained shear strength; this usually (but not always) means that the drained condition may be more critical (with respect to the overall stability and the passive resistance of the bearing stratum in a sheet pile problem). On the other hand, if w is closer to LL , the clay may be expected to be soft (Table 3-4), normally consolidated, and have a low, undrained shear strength; and this usually means that the undrained condition will be more critical.

Table 3-1
Granular Soil Properties (after Teng 1962)

| Compactness | Relative Density (%) | SPT N (blows per ft) | Angle of Internal Friction (deg) | Unit Weight | |
|-------------|----------------------|----------------------|----------------------------------|-------------|-----------------|
| | | | | Moist (pcf) | Submerged (pcf) |
| Very Loose | 0-15 | 0-4 | <28 | <100 | <60 |
| Loose | 16-35 | 5-10 | 28-30 | 95-125 | 55-65 |
| Medium | 36-65 | 11-30 | 31-36 | 110-130 | 60-70 |
| Dense | 66-85 | 31-50 | 37-41 | 110-140 | 65-85 |
| Very Dense | 86-100 | >51 | >41 | >130 | >75 |

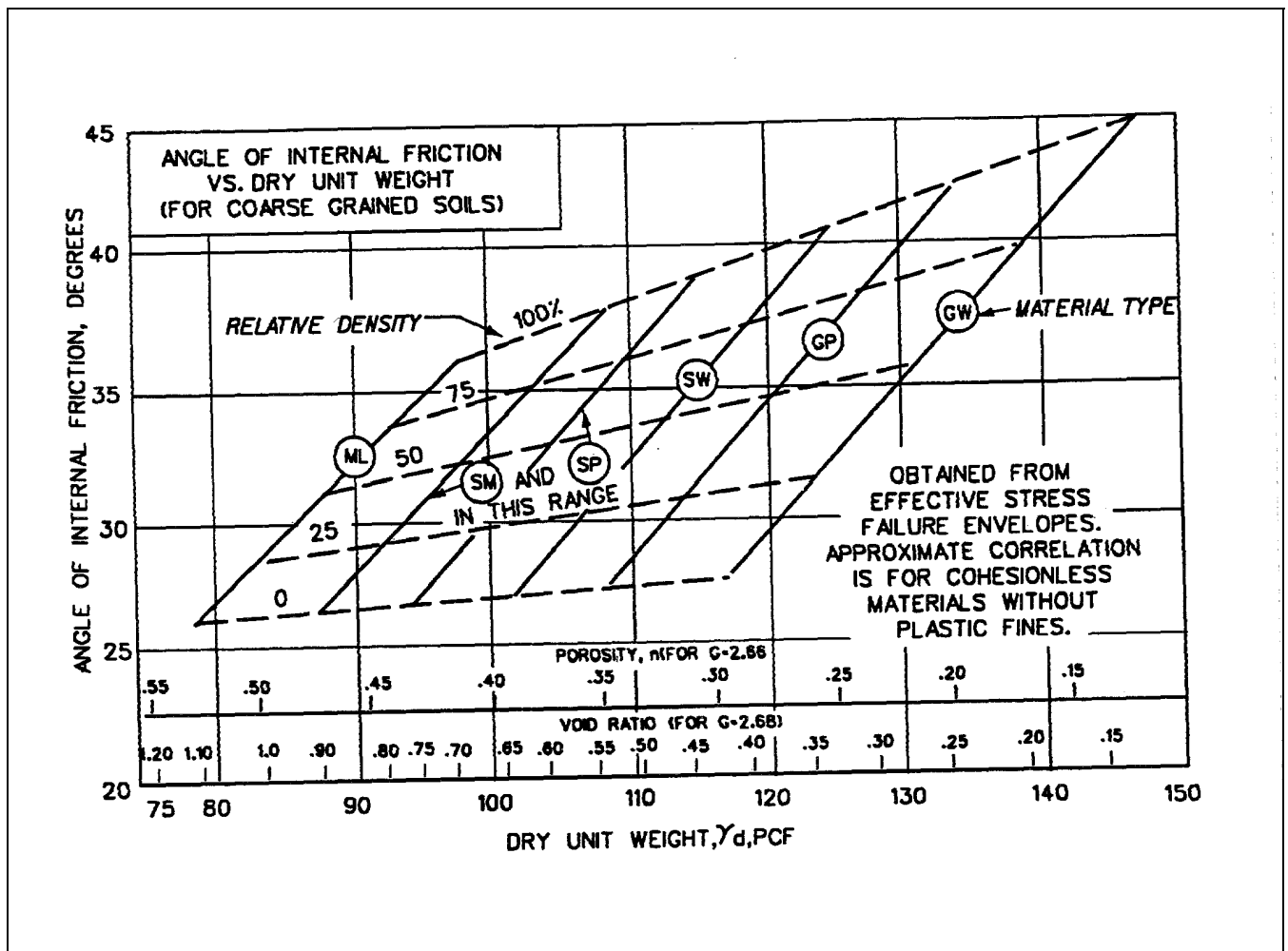

Figure 3-1. Cohesionless Soil Properties (after U.S. Department of the Navy 1971)

Table 3-2
Ratio of ϕ/δ (After Allen, Duncan, and Snacio 1988)

| Soil Type | Steel | Wood | Concrete |
|-------------|----------------------|----------------------|----------------------|
| Sand | $\delta/\phi = 0.54$ | $\delta/\phi = 0.76$ | $\delta/\phi = 0.76$ |
| Silt & Clay | $\delta/\phi = 0.54$ | $\delta/\phi = 0.55$ | $\delta/\phi = 0.50$ |

Table 3-3
Values of δ for Various Interfaces
(after U.S. Department of the Navy 1982)

| Soil Type | δ (deg) |
|--|----------------|
| (a) Steel sheet piles | |
| Clean gravel, gravel sand mixtures, well-graded rockfill with spalls | 22 |
| Clean sand, silty sand-gravel mixture, single-size hard rockfill | 17 |
| Silty sand, gravel or sand mixed with silt or clay | 14 |
| Fine sandy silt, nonplastic silt | 11 |
| (b) Concrete sheet piles | |
| Clean gravel, gravel sand mixtures, well-graded rockfill with spalls | 22-26 |
| Clean sand, silty sand-gravel mixture, single-size hard rockfill | 17-22 |
| Silty sand, gravel or sand mixed with silt or clay | 17 |
| Fine sandy silt, nonplastic silt | 14 |

Table 3-4
Correlation of Undrained Shear Strength of Clay ($q_u=2c$)

| Consistency | q_u (psf) | SPT (blows/ft) | Saturated Unit Weight (psf) |
|-------------|-------------|----------------|-----------------------------|
| Very Soft | 0-500 | 0-2 | <100-110 |
| Soft | 500-1,000 | 3-4 | 100-120 |
| Medium | 1,000-2,000 | 5-8 | 110-125 |
| Stiff | 2,000-4,000 | 9-16 | 115-130 |
| Very Stiff | 4,000-8,000 | 16-32 | 120-140 |
| Hard | >8,000 | >32 | >130 |

(5) Since an undrained condition may be expected to occur under "fast" loading in the field, it represents a "short-term" condition; in time, drainage will occur, and the drained strength will govern (the "long-term" condition). To model these conditions in the laboratory, three types of tests are generally used; unconsolidated undrained (Q or UU), consolidated undrained (R or CU), and consolidated drained (S or CD). Undrained shear strength in the laboratory is determined from either Q or R tests and drained shear strength is established from S tests or from consolidated undrained tests with pore pressure measurements (\bar{R}).

(6) The undrained shear strength, S_u , of a normally consolidated clay is usually expressed by only a cohesion intercept; and it is labeled c_u to indicate that ϕ was taken as zero. c_u decreases dramatically with water content; therefore, in design it is common to consider the fully saturated condition even if a clay is partly saturated in the field. Typical undrained shear strength values are presented in Table 3-4. S_u increases with depth (or effective stress) and this is commonly expressed with the ratio " S_u/p " (p denotes the effective vertical stress). This ratio correlates roughly with plasticity index and overconsolidation ratio (Figures 3-2, 3-3, respectively). The undrained shear strength of many overconsolidated soils is further complicated due to the presence of fissures; this leads to a lower field strength than tests on small laboratory samples indicate.

(7) The drained shear strength of normally consolidated clays is similar to that of loose sands ($c' = 0$), except that ϕ is generally lower. An empirical correlation of the effective angle of internal friction, ϕ' , with plasticity index for normally consolidated clays is shown in Figure 3-4. The drained shear strength of overconsolidated clays is similar to that of dense sands (again with lower ϕ'), where there is a peak strength ($c' \text{ nonzero}$) and a "residual" shear strength ($c' = 0$).

(8) The general approach in solving problems involving clay is that, unless the choice is obvious, both undrained and drained conditions are analyzed separately. The more critical condition governs the design. Total stresses are used in an analysis with undrained shear strength (since pore pressures are "included" in the undrained shear strength) and effective stresses in a drained case; thus such analyses are usually called total and effective stress analyses, respectively.

(9) At low stress levels, such as near the top of a wall, the undrained strength is greater than the drained

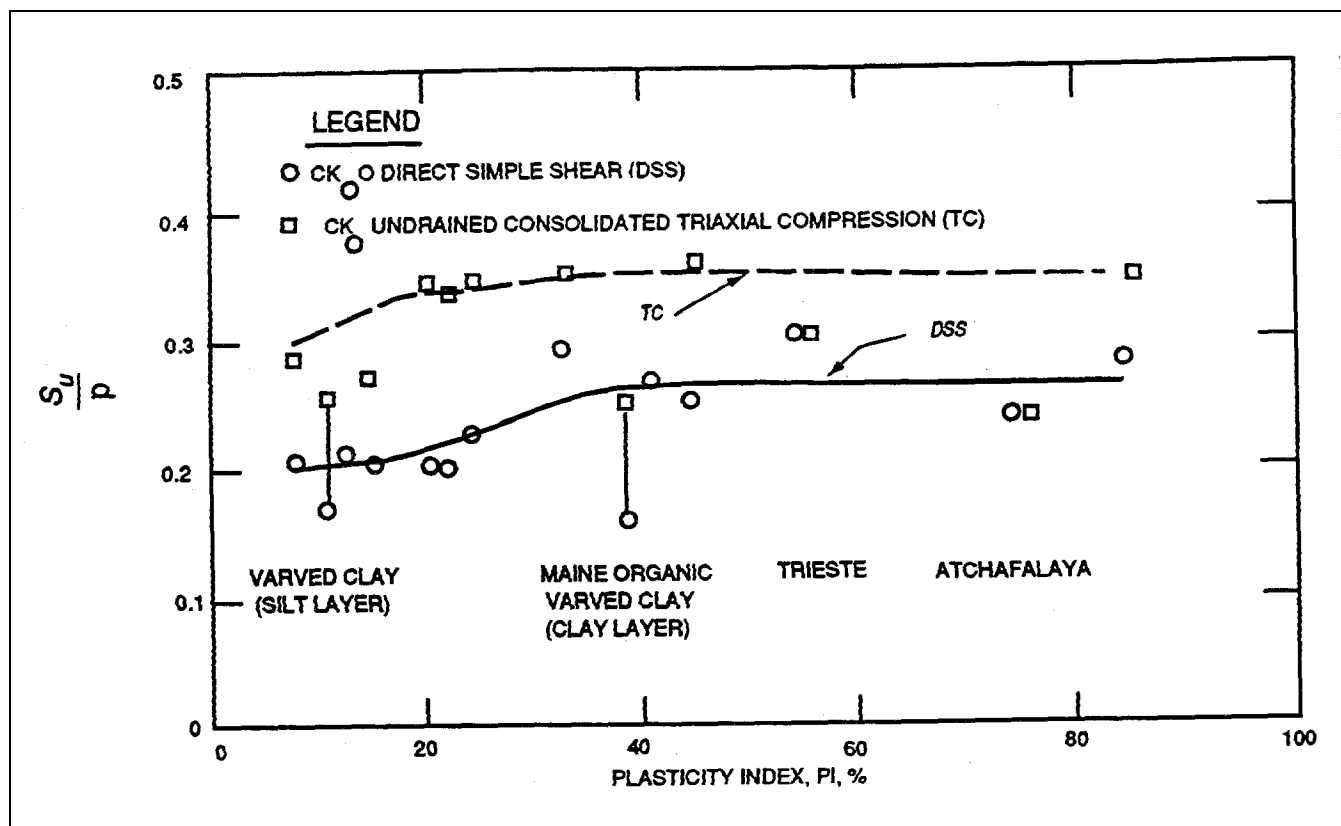

Figure 3-2. Relationship between the ratio S_u/p and plasticity index for normally consolidated clays (after Gardner 1977)

strength due to the generation of negative pore pressures which can dissipate with time. Such negative pore pressures allow steep temporary cuts to be made in clay soils. Active earth pressures calculated using undrained parameters are minimum (sometimes negative) values that may be unconservative for design. They should be used, however, to calculate crack depths when checking the case of a water-filled crack.

(10) At high stress levels, such as below the base of a high wall, the undrained strength is lower than the drained strength due to generation of positive pore pressures during shear. Consequently, the mass stability of walls on fine-grain foundations should be checked using both drained and undrained strengths.

(11) Certain materials such as clay shales exhibit greatly reduced shear strength once shearing has initiated. For walls founded on such materials, sliding analyses should include a check using residual shear strengths.

3-4. In Situ Testing of Foundation Materials

a. Advantages. For designs involving coarse-grain foundation materials, undisturbed sampling is usually impractical and in situ testing is the only way to obtain an estimate of material properties other than pure assumption. Even where undisturbed samples can be obtained, the use of in situ methods to supplement conventional tests may provide several advantages: lower costs, testing of a greater volume of material, and testing at the in situ stress state. Although numerous types of in situ tests have been devised, those most currently applicable to wall design are the SPT, the cone penetration test (CPT), and the pressuremeter test (PMT).

b. Standard penetration test. The SPT (ASTM D-1586 (1984)) is routinely used to estimate the relative density and friction angle of sands using empirical correlations. To minimize effects of overburden stress, the penetration resistance, or N value (blows per foot), is usually corrected to an effective vertical overburden

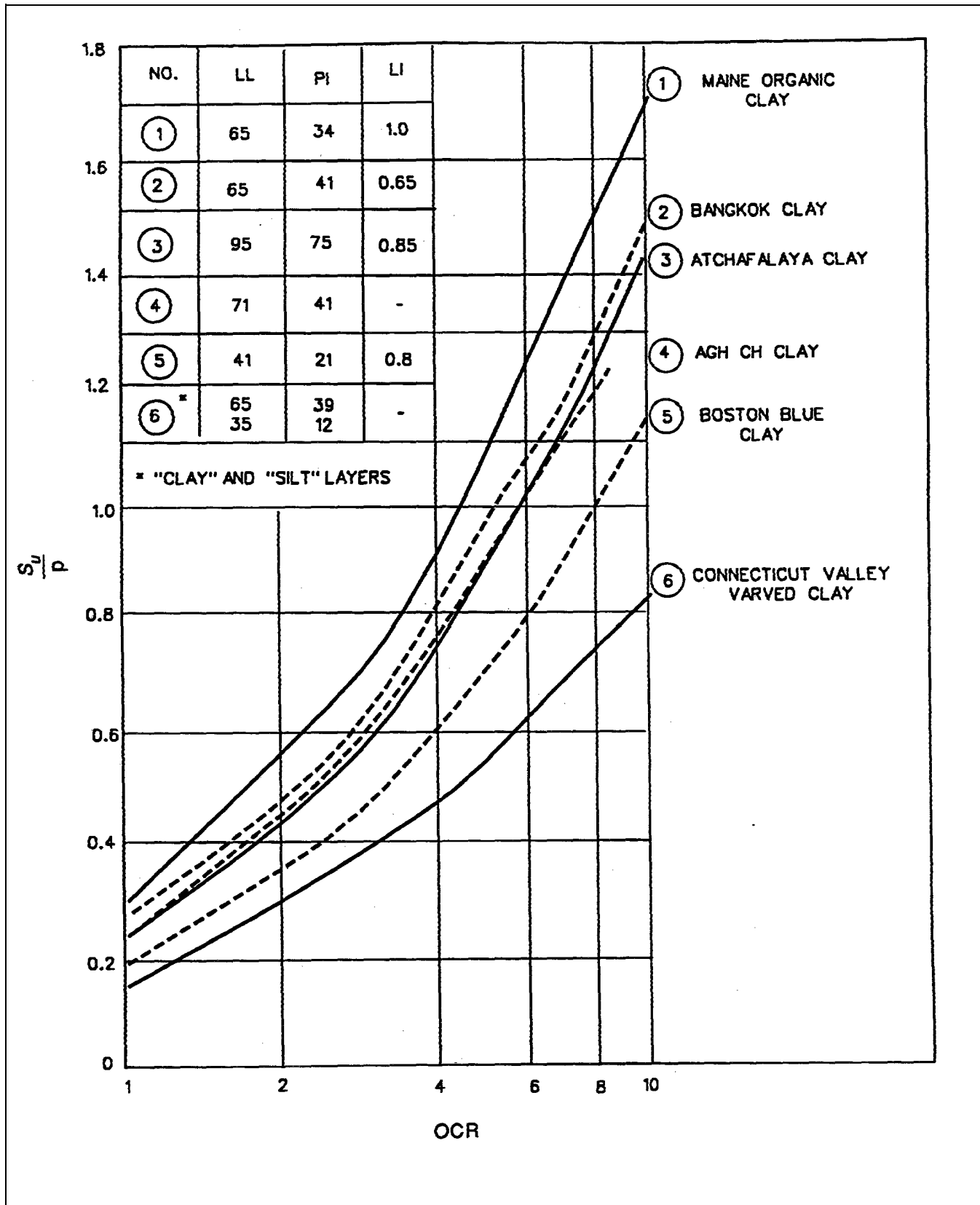

Figure 3-3. Undrained strength ratio versus over-consolidation ratio (after Ladd et al. 1977)

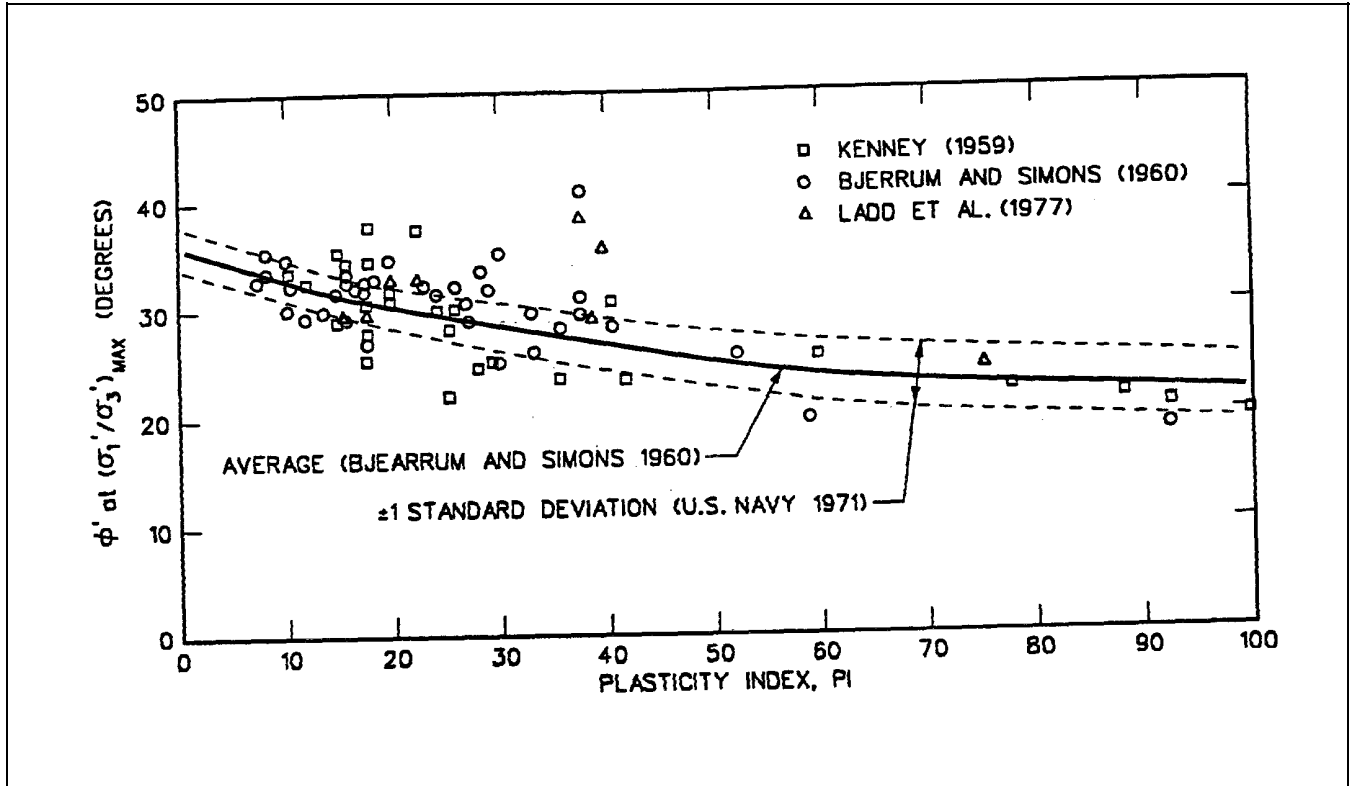

Figure 3-4. Empirical correlation between friction angle and PI from triaxial tests on normally consolidated clays

stress of 1 ton per square foot using an equation of the form:

$$N' = C_N N \quad (3-1)$$

where

N' = corrected resistance

C_N = correction factor

N = measured resistance

Table 3-5 and Figure 3-5 summarize the some most commonly proposed values for C_N . Whitman and Liao (1984) developed the following expression for C_N :

$$C_N = \sqrt{\frac{1}{\sigma'_{vo}}} \quad (3-2)$$

where effective stress due to overburden, σ'_{vo} , is expressed in tons per square foot. The drained friction angle ϕ' can be estimated from N' using Figure 3-6. The

relative density of normally consolidated sands can be estimated from the correlation obtained by Marcuson and Bieganousky (1977):

$$D_r = 11.7 + 0.76[|222(N) + 1600 - 53(p'_{vo}) - 50(C_u)^2|]^{1/2} \quad (3-3)$$

where

p'_{vo} = effective overburden pressure in pounds per square inch

C_u = coefficient of uniformity (D_{60}/D_{10})

Correlations have also been proposed between the SPT and the undrained strength of clays (see Table 3-4). However, these are generally unreliable and should be used for very preliminary studies only and for checking the reasonableness of SPT and lab data.

c. *Cone penetration test.* The CPT (ASTM D 3441-79 (1986a)) is widely used in Europe and is gaining

Table 3-5
SPT Correction to 1 tsf (2 ksf)

| Effective Overburden Stress kips/sq ft | Correction factor C_N | | |
|---|-------------------------------|--------------------------|------------------------------------|
| | Seed, Arango, and Chan (1975) | Peck and Bazarara (1969) | Peck, Hanson, and Thornburn (1974) |
| 0.20 | 2.25 | 2.86 | |
| 0.40 | 1.87 | 2.22 | 1.54 |
| 0.60 | 1.65 | 1.82 | 1.40 |
| 0.80 | 1.50 | 1.54 | 1.31 |
| 1.00 | 1.38 | 1.33 | 1.23 |
| 1.20 | 1.28 | 1.18 | 1.17 |
| 1.40 | 1.19 | 1.05 | 1.12 |
| 1.60 | 1.12 | 0.99 | 1.08 |
| 1.80 | 1.06 | 0.96 | 1.04 |
| 2.00 | 1.00 | 0.94 | 1.00 |
| 2.20 | 0.95 | 0.92 | 0.97 |
| 2.40 | 0.90 | 0.90 | 0.94 |
| 2.60 | 0.86 | 0.88 | 0.91 |
| 2.80 | 0.82 | 0.86 | 0.89 |
| 3.00 | 0.78 | 0.84 | 0.87 |
| 3.20 | 0.74 | 0.82 | 0.84 |
| 3.40 | 0.71 | 0.81 | 0.82 |
| 3.60 | 0.68 | 0.79 | 0.81 |
| 3.80 | 0.65 | 0.78 | 0.79 |
| 4.00 | 0.62 | 0.76 | 0.77 |
| 4.20 | 0.60 | 0.75 | 0.75 |
| 4.40 | 0.57 | 0.73 | 0.74 |
| 4.60 | 0.55 | 0.72 | 0.72 |
| 4.80 | 0.52 | 0.71 | 0.71 |
| 5.00 | 0.50 | 0.70 | 0.70 |

considerable acceptance in the United States. The interpretation of the test is described by Robertson and Campanella (1983). For coarse-grain soils, the cone resistance q_c has been empirically correlated with standard penetration resistance (N value). The ratio (q_c/N) is typically in the range of 2 to 6 and is related to medium grain size (Figure 3-7). The undrained strength of fine-grain soils may be estimated by a modification of bearing capacity theory:

$$s_u = \frac{q_c - p_o}{N_k} \quad (3-4)$$

where

p_o = the in situ total overburden pressure

N_k = empirical cone factor typically in the range of 10 to 20

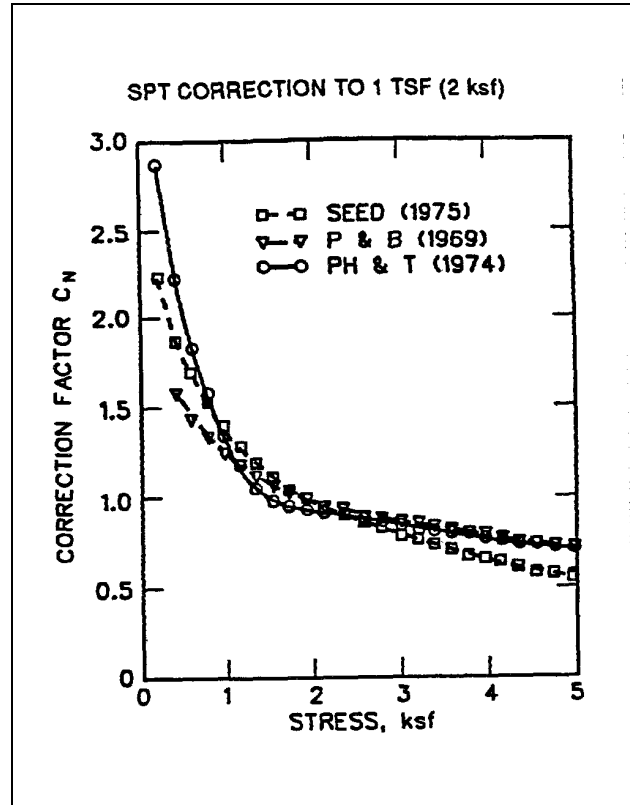

Figure 3-5. SPT correction to 1 tsf

The N_k value should be based on local experience and correlation to laboratory tests. Cone penetration tests also may be used to infer soil classification to supplement physical sampling. Figure 3-8 indicates probable soil type as a function of cone resistance and friction ratio. Cone penetration tests may produce erratic results in gravelly soils.

d. Pressuremeter test. The PMT also originated in Europe. Its use and interpretation are discussed by Baguelin, Jezequel, and Shields (1978). Test results are normally used to directly calculate bearing capacity and settlements, but the test can be used to estimate strength parameters. The undrained strength of fine-grain materials is given by:

$$s_u = \frac{p_1 - p_{ho}}{2K_b} \quad (3-5)$$

where

p_1 = limit pressure

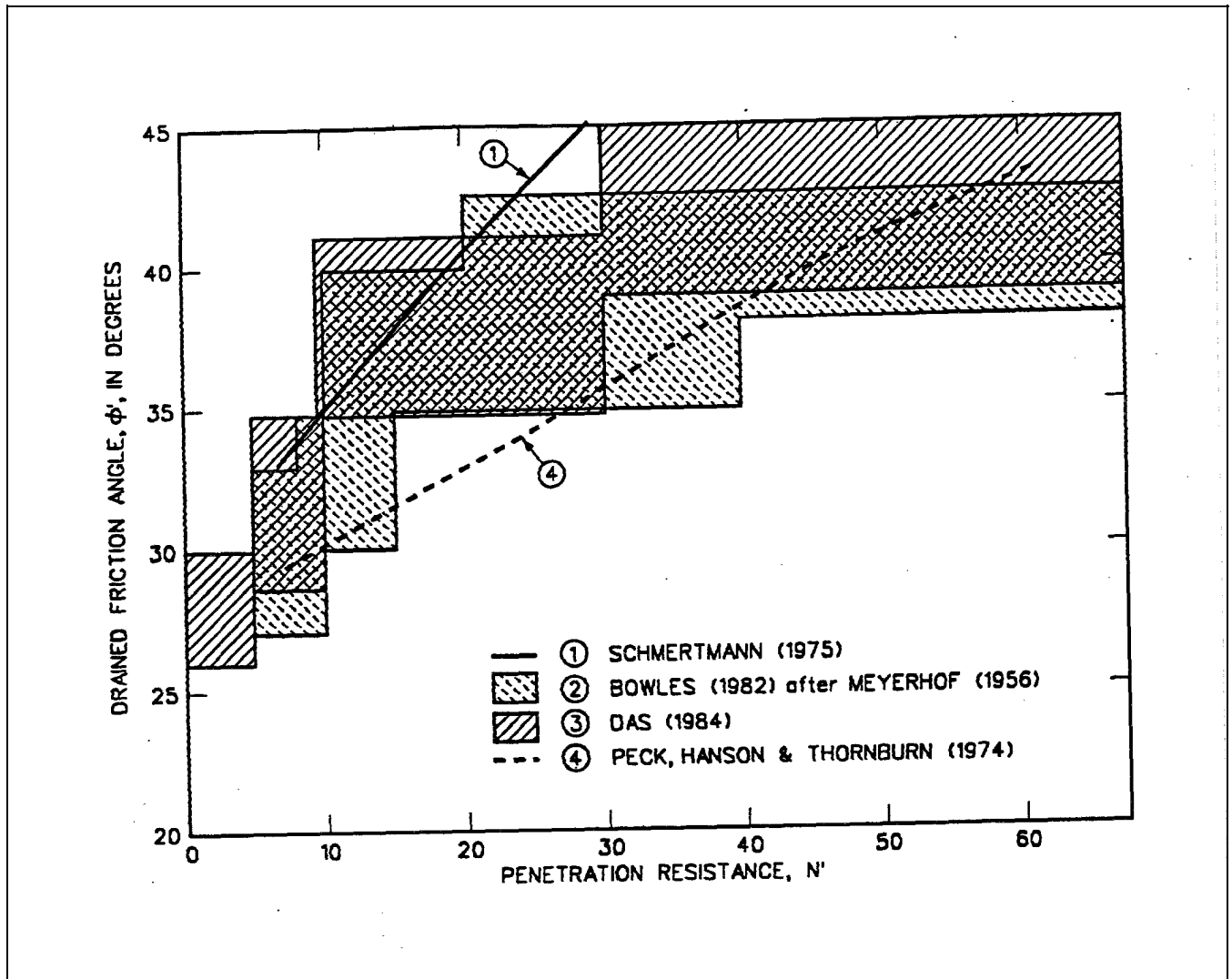

Figure 3-6. Correlations between SPT results and shear strength of granular materials

p_{ho}' = effective at-rest horizontal pressure

K_b = a coefficient typically in the range of 2.5 to 3.5 for most clays

Again, correlation with laboratory tests and local experience is recommended.

3-5. Design Strength Selection

As soils are heterogenous (or random) materials, strength tests invariably exhibit scattered results. The

guidance contained in EM 1110-2-1902 regarding the selection of design strengths at or below the thirty-third percentile of the test results is also applicable to walls. For small projects, conservative selection of design strengths near the lower bound of plausible values may be more cost-effective than performing additional tests. Where expected values of drained strengths (ϕ values) are estimated from correlations, tables, and/or experience, a design strength of 90 percent of the expected (most likely) value will usually be sufficiently conservative.

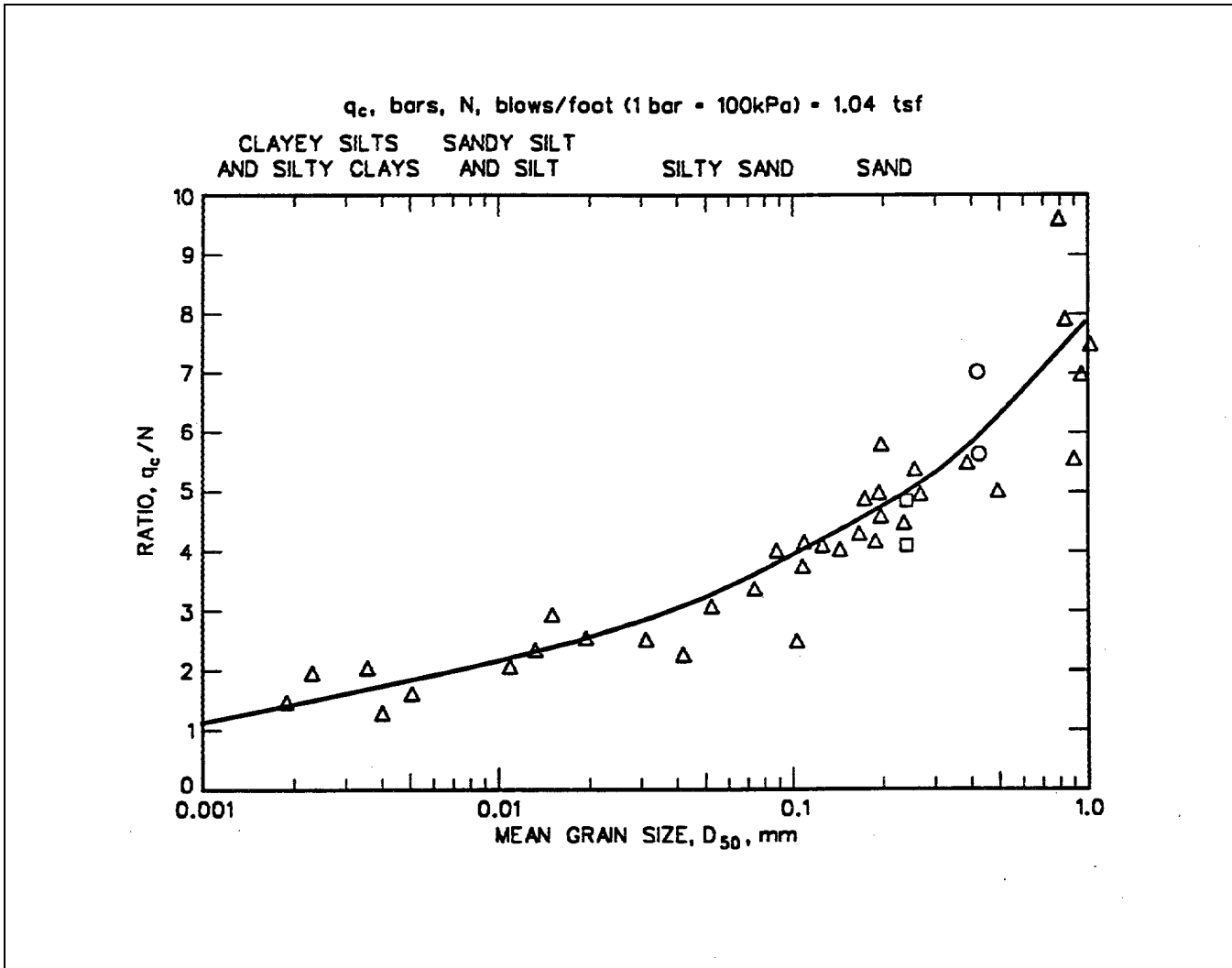

Figure 3-7. Correlation between grain size and the ratio of cone bearing and STP resistance (after Robertson and Campanella 1983)

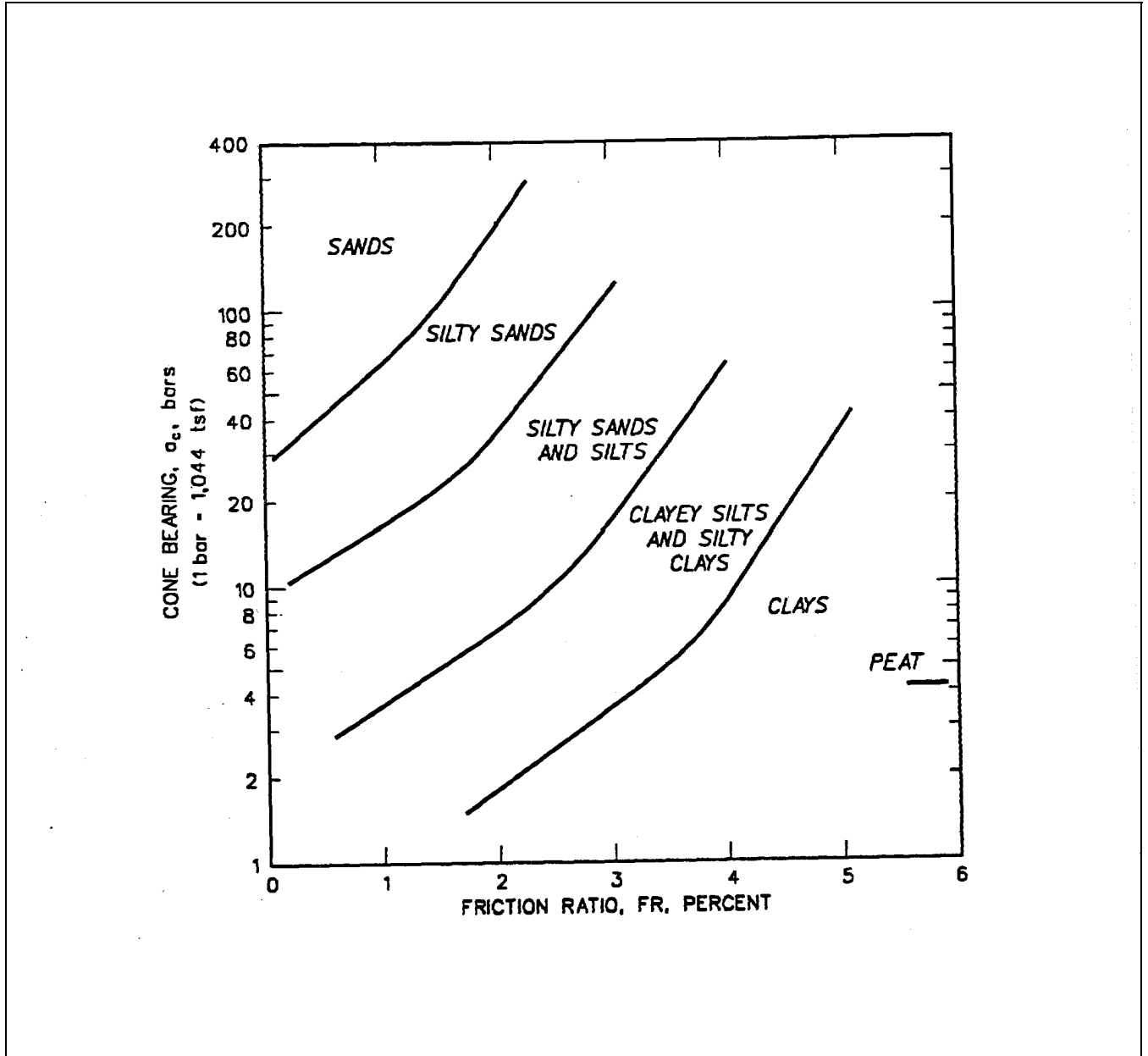

Figure 3-8. Soil classification from cone penetrometer (after Robertson and Campanella 1983)

Chapter 4 System Loads

4-1. General

The loads governing the design of a sheet pile wall arise primarily from the soil and water surrounding the wall and from other influences such as surface surcharges and external loads applied directly to the piling. Current methodologies for evaluating these loads are discussed in the following paragraphs.

4-2. Earth Pressures

Earth pressures reflect the state of stress in the soil mass. The concept of an earth pressure coefficient, K , is often used to describe this state of stress. The earth pressure coefficient is defined as the ratio of horizontal stresses to the vertical stresses at any depth below the soil surface:

$$K = \frac{\sigma_h}{\sigma_v} \quad (4-1)$$

Earth pressures for any given soil-structure system may vary from an initial state of stress referred to as at-rest, K_o , to minimum limit state referred to as active, K_A , or to a maximum limit state referred to as passive, K_P . The magnitude of the earth pressure exerted on the wall depends, among other effects, on the physical and strength properties of the soil, the interaction at the soil-structure interface, the ground-water conditions, and the deformations of the soil-structure system. These limit states are determined by the shear strength of the soil:

$$\tau_f = c + \sigma_n \tan \phi \quad (4-2)$$

where

τ_f and σ_n = shear and normal stresses on a failure plane

c and ϕ = shear strength parameters of the soil, cohesion, and angle of internal friction, respectively (Figure 4-1)

a. At-rest pressures. At-rest pressure refers to a state of stress where there is no lateral movement or

strain in the soil mass. In this case, the lateral earth pressures are the pressures that existed in the ground prior to installation of a wall. This state of stress is shown in Figure 4-2 as circle O on a Mohr diagram.

b. Active pressures. Active soil pressure is the minimum possible value of horizontal earth pressure at any depth. This pressure develops when the walls move or rotate away from the soil allowing the soil to expand horizontally in the direction of wall movement. The state of stress resulting in active pressures is shown in Figure 4-2 as circle A.

c. Passive pressures. Passive (soil) pressure is the maximum possible horizontal pressure that can be developed at any depth from a wall moving or rotating toward the soil and tending to compress the soil horizontally. The state of stress resulting in passive pressures is shown in Figure 4-2 as circle P.

d. Wall movements. The amount of movement required to develop minimum active or maximum passive earth pressures depends on the stiffness of the soil and the height of the wall. For stiff soils like dense sands or heavily overconsolidated clays, the required movement is relatively small. An example is shown in Figure 4-3 which indicates that a movement of a wall away from the fill by 0.3 percent of the wall height is sufficient to develop minimum pressure, while a movement of 2.0 percent of the wall height toward the fill is sufficient to develop the maximum pressure. For all sands of medium or higher density, it can be assumed that the movement required to reach the minimum active earth pressure is no more than about 0.4 percent of the wall height, or about 1 inch of movement of a 20-foot-high wall. The movement required to increase the earth pressure to its maximum passive value is about 10 times that required for the minimum, about 4.0 percent of the wall height or about 10 inches of movement for a 20-foot-high wall. For loose sands, the movement required to reach the minimum active or the maximum passive is somewhat larger. The classical design procedures described in this chapter assume that the sheet pile walls have sufficient flexibility to produce the limit state, active or passive earth pressures. A method to account for intermediate to extreme values of earth pressure by soil-structure interaction analysis is presented in Chapter 7.

e. Wall friction and adhesion. In addition to the horizontal motion, relative vertical motion along the wall soil interface may result in vertical shearing

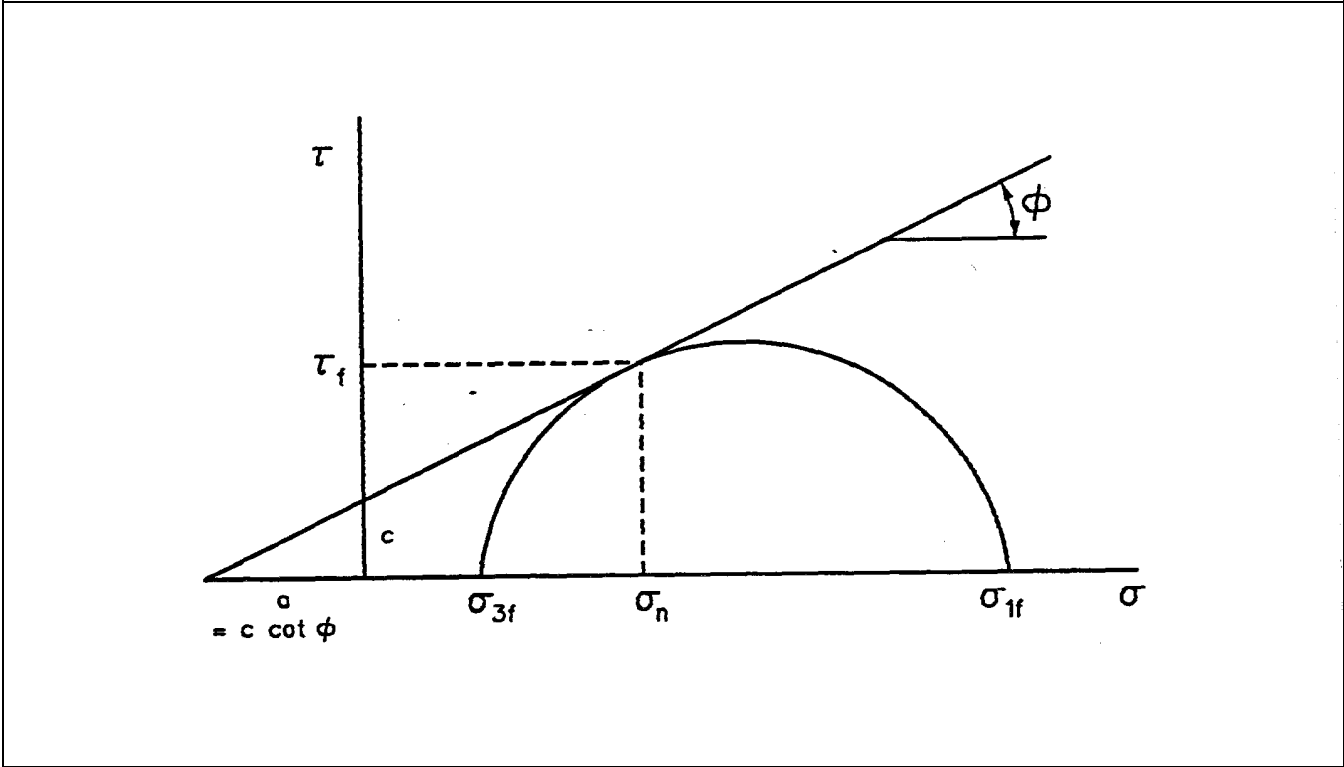

Figure 4-1. Shear strength parameters

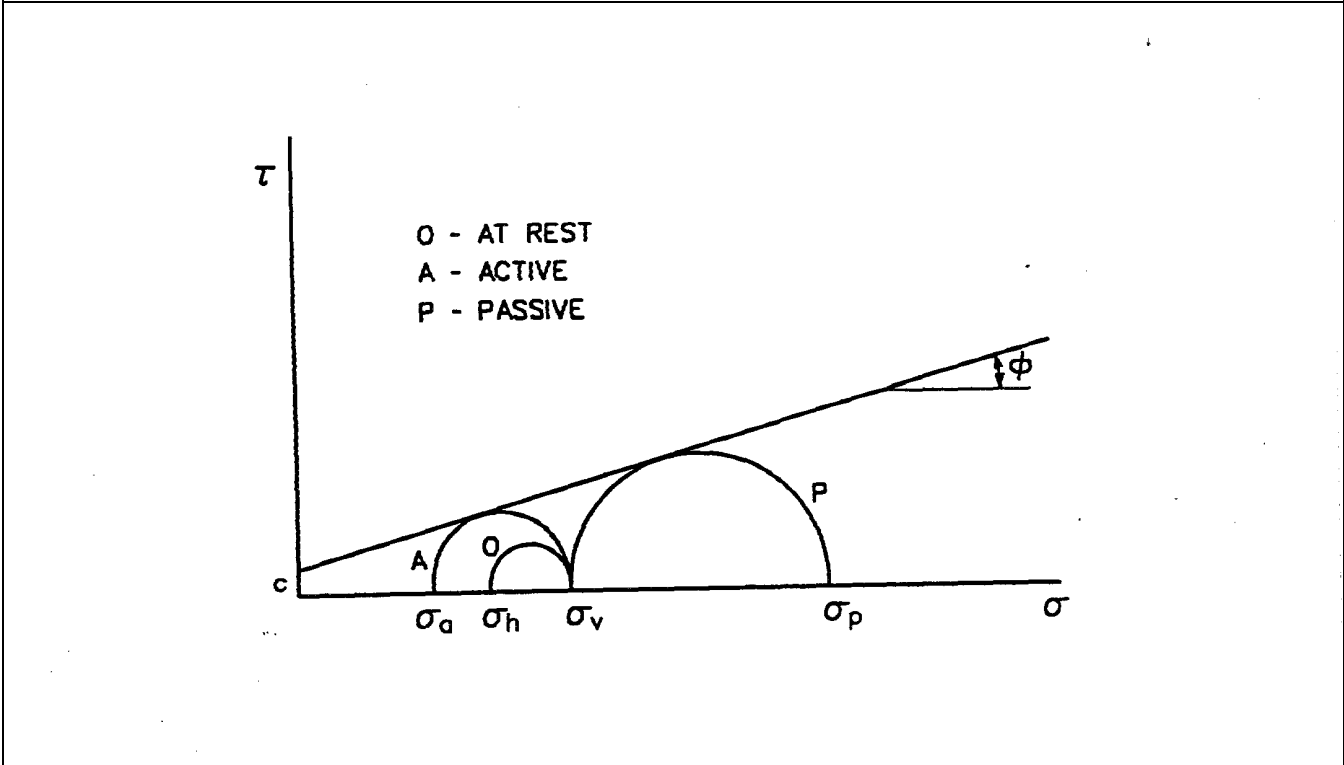

Figure 4-2. Definition of active and passive earth pressures

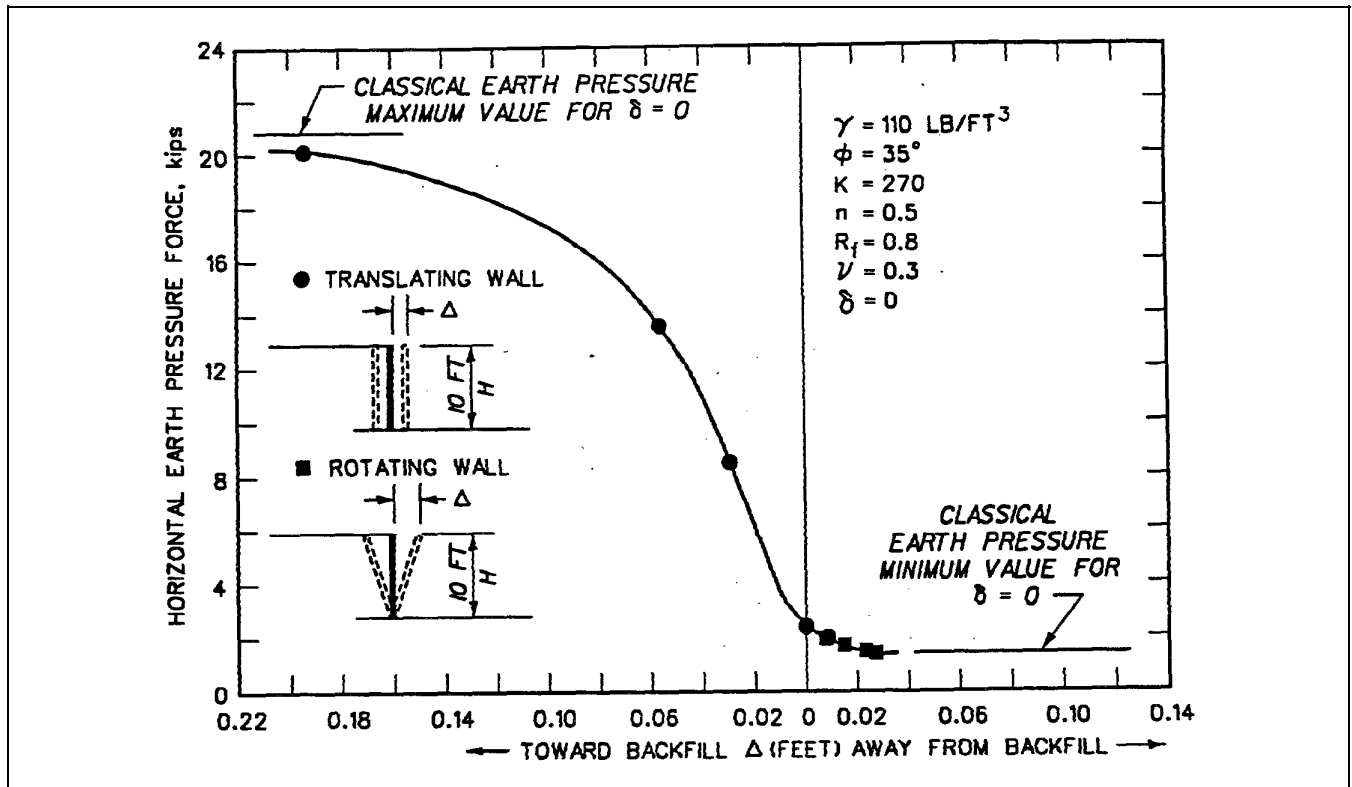

Figure 4-3. Variations of earth pressure force with wall movement calculated by finite element analyses (after Clough and Duncan 1971)

stresses due to wall/soil friction in the case of granular soils or in wall/soil adhesion for cohesive soils. This will have an effect on the magnitude of the minimum and maximum horizontal earth pressures. For the minimum or active limit state, wall friction or adhesion will slightly decrease the horizontal earth pressure. For the maximum or passive limit state, wall friction or adhesion may significantly increase the horizontal earth pressure depending on its magnitude.

4-3. Earth Pressure Calculations

Several earth pressures theories are available for estimating the minimum (active) and maximum (passive) lateral earth pressures that can develop in a soil mass surrounding a wall. A detailed discussion of various theories is presented by Mosher and Oner (1989). The Coulomb theory for lateral earth pressure will be used for the design of sheet pile walls.

a. Coulomb Theory. The evaluation of the earth pressures is based on the assumption that a failure plane develops in the soil mass, and along that failure the shear and normal forces are related by the shear strength

expression (Equation 4-2). This makes the problem statically determinate. Free-body diagrams of a wedge of homogeneous soil bounded by the soil surface, the sheet pile wall, and a failure plane are shown in Figure 4-4. Equilibrium analysis of the forces shown in Figure 4-4 allows the active force, P_a , or passive force, P_p , to be expressed in terms of the geometry and shear strength:

γ = unit weight of the homogeneous soil

ϕ = angle of internal soil friction

c = cohesive strength of the soil

δ = angle of wall friction

θ = angle between the wall and the failure plane

z = depth below the ground surface

β = slope of the soil surface

For the limit state (minimum and maximum), active or passive, the angle i , critical angle at failure, is obtained from $dP/d\theta = 0$. Finally, the soil pressure at depth z is obtained from $p = dP/dz$. These operations result in

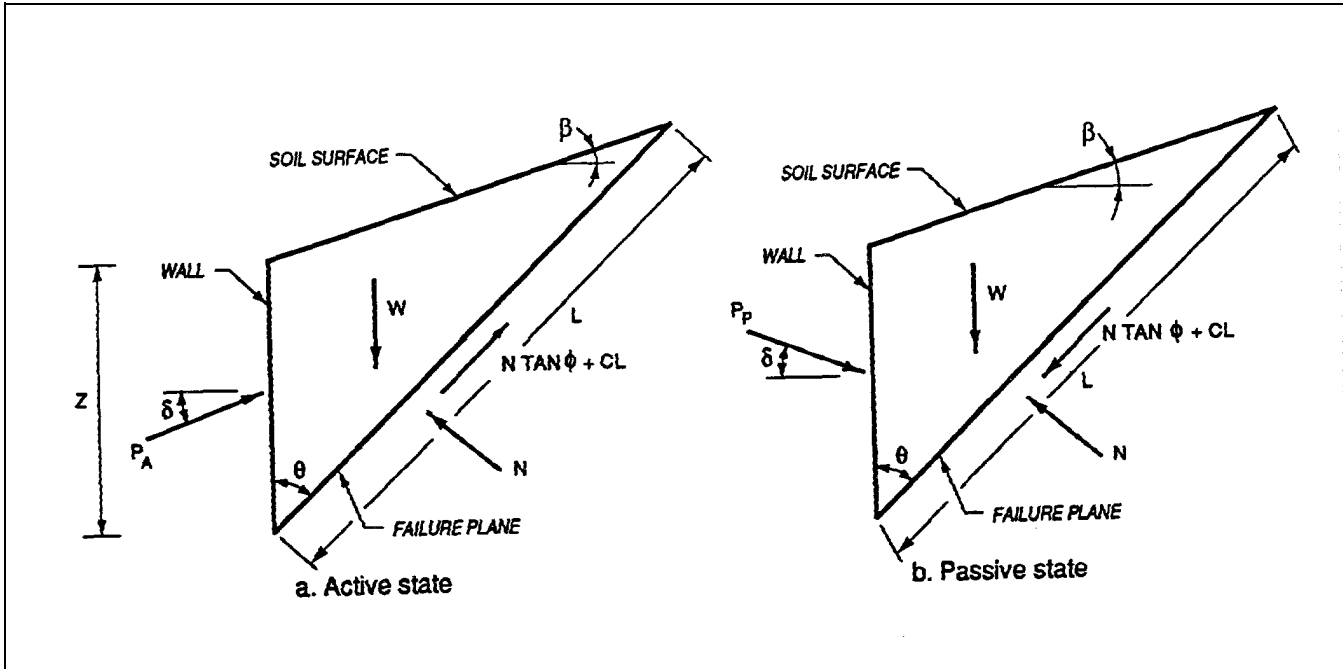

Figure 4-4. Soil wedges for Coulomb earth pressure theory

values of active pressure given by

$$p_a = \gamma z K_A - 2c \sqrt{K_A} \quad (4-3)$$

and passive pressure given by

$$p_p = \gamma z K_p + 2c \sqrt{K_p} \quad (4-4)$$

where K_A and K_p are coefficients of active and passive earth pressures given by

$$K_A = \frac{\cos^2(\phi - \theta)}{\cos^2\theta \cos(\theta + \delta) \left[1 + \frac{\sin(\phi + \delta)\sin(\phi - \beta)}{\cos(\delta + \phi)\cos(\beta - \phi)} \right]^2} \quad (4-5)$$

and

$$K_p = \frac{\cos^2(\phi - \theta)}{\cos^2\theta \cos(\theta + \delta) \left[1 - \frac{\sin(\phi + \delta)\sin(\phi + \beta)}{\cos(\delta - \phi)\cos(\beta - \phi)} \right]^2} \quad (4-6)$$

b. Coefficient method for soil pressures. The Coulomb theory outlined in paragraph 4.3a, although originally developed for homogeneous soils, is assumed

to apply to layered soil systems composed of horizontal, homogeneous layers. The product γz in Equations 4-3 and 4-4 is the geostatic soil pressure at depth z in the homogeneous system. In a layered system this term is replaced by the effective vertical soil pressure p_v at depth z including the effects of submergence and seepage on the soil unit weight. The active and passive earth pressures at any point are obtained from

$$p_a = p_v K_A - 2c\sqrt{K_A} \quad (4-7)$$

and

$$p_p = p_v K_p + 2c\sqrt{K_p} \quad (4-8)$$

where K_A and K_p are the coefficients of active and passive earth pressure from equations 4-5 and 4-6 with ϕ and c being the "effective" (see subsequent discussion of soil factor of safety) strength properties and δ is the angle of wall friction at the point of interest. This procedure can result in large discontinuities in calculated pressure distributions at soil layer boundaries.

c. *Wedge methods for soil pressures.* The coefficient method does not account for the effects of sloping ground surface, sloping soil layer boundaries, or the presence of wall/soil adhesion. When any these effects are present, the soil pressures are calculated by a numerical procedure, a wedge method, based on the fundamental assumptions of the Coulomb theory. Practical evaluation of soil pressures by the wedge method requires a computer program. (CWALSHT User's Guide (USAEWES 1990) or CWALSSI User's Guide (Dawkins 1992).)

4-4. Surcharge Loads

Loads due to stockpiled material, machinery, roadways, and other influences resting on the soil surface in the vicinity of the wall increase the lateral pressures on the wall. When a wedge method is used for calculating the earth pressures, the resultant of the surcharge acting on the top surface of the failure wedge is included in the equilibrium of the wedge. If the soil system admits to application of the coefficient method, the effects of surcharges, other than a uniform surcharge, are evaluated from the theory of elasticity solutions presented in the following paragraphs.

a. *Uniform surcharge.* A uniform surcharge is assumed to be applied at all points on the soil surface. The effect of the uniform surcharge is to increase the effective vertical soil pressure, p_v in Equations 4-7 and 4-8, by an amount equal to the magnitude of the surcharge.

b. *Strips loads.* A strip load is continuous parallel to the longitudinal axis of the wall but is of finite extent perpendicular to the wall as illustrated in Figure 4-5. The additional pressure on the wall is given by the equations in Figure 4-5. Any negative pressures calculated for strips loads are to be ignored.

c. *Line loads.* A continuous load parallel to the wall but of narrow dimension perpendicular to the wall may be treated as a line load as shown in Figure 4-6. The lateral pressure on the wall is given by the equation in Figure 4-6.

d. *Ramp load.* A ramp load, Figure 4-7, increases linearly from zero to a maximum which subsequently remains uniform away from the wall. The ramp load is assumed to be continuous parallel to the wall. The equation for lateral pressure is given by the equation in Figure 4-7.

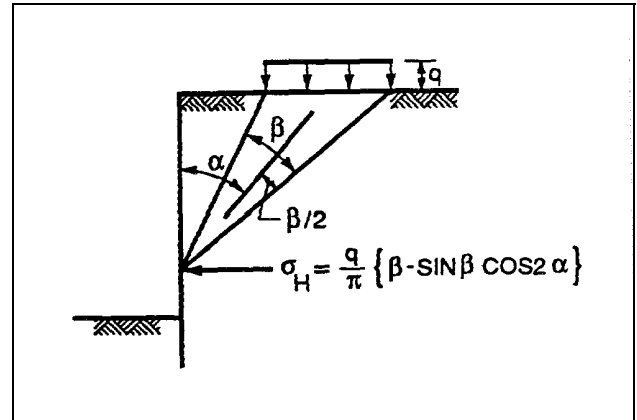

Figure 4-5. Strip load

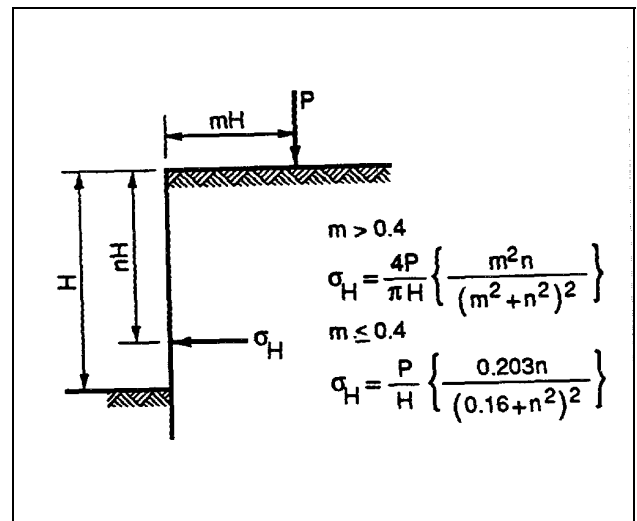

Figure 4-6. Line load

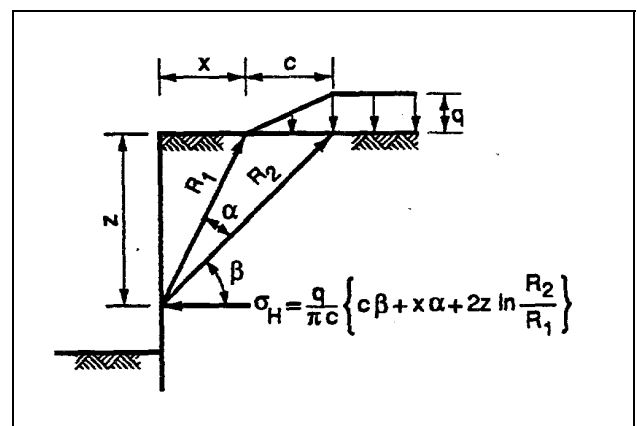

Figure 4-7. Ramp load

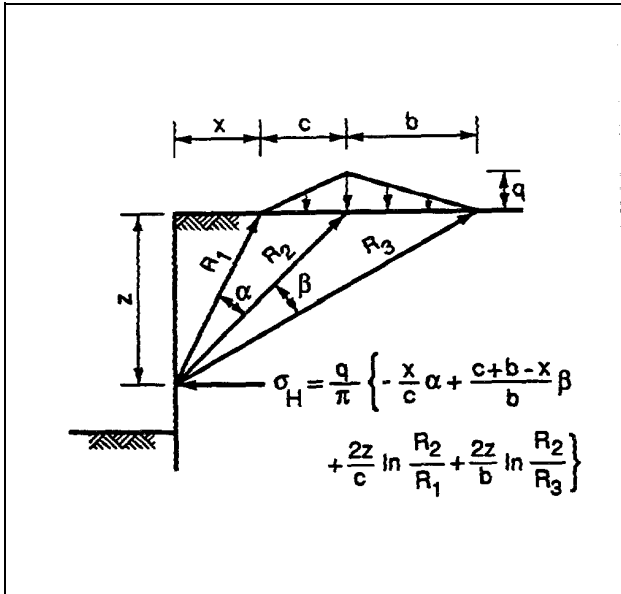

Figure 4-8. Triangular load

e. Triangular loads. A triangular load varies perpendicular to the wall as shown in Figure 4-8 and is assumed to be continuous parallel to the wall. The equation for lateral pressure is given in Figure 4-8.

f. Area loads. A surcharge distributed over a limited area, both parallel and perpendicular to the wall, should be treated as an area load. The lateral pressures induced by area loads may be calculated using Newmark's Influence Charts (Newmark 1942). The lateral pressures due to area loads vary with depth below the ground surface and with horizontal distance parallel to the wall. Because the design procedures discussed subsequently are based on a typical unit slice of the wall/soil system, it may be necessary to consider several slices in the vicinity of the area load.

g. Point loads. A surcharge load distributed over a small area may be treated as a point load. The equations for evaluating lateral pressures are given in Figure 4-9. Because the pressures vary horizontally parallel to the wall; it may be necessary to consider several unit slices of the wall/soil system for design.

4-5. Water Loads

a. Hydrostatic pressure. A difference in water level on either side of the wall creates an unbalanced hydrostatic pressure. Water pressures are calculated by multiplying the water depth by its specific weight. If a nonflow hydrostatic condition is assumed, i.e. seepage

effects neglected, the unbalanced hydrostatic pressure is assumed to act along the entire depth of embedment. Water pressure must be added to the effective soil pressures to obtain total pressures.

b. Seepage effects. Where seepage occurs, the differential water pressure is dissipated by vertical flow beneath the sheet pile wall. This distribution of the unbalanced water pressure can be obtained from a seepage analysis. The analysis should consider the permeability of the surrounding soils as well as the effectiveness of any drains if present. Techniques of seepage analysis applicable to sheet pile wall design include flow nets, line of creep method, and method of fragments. These simplified techniques may or may not yield conservative results. Therefore, it is the designer's responsibility to decide whether the final design should be based on a more rigorous analysis, such as the finite element method. Upward seepage in front of the sheet pile wall tends to reduce the effective weight of the soil, thus reducing its ability to offer lateral support. In previous material the effects of upward seepage can cause piping of material away from the wall or, in extreme cases, cause the soil to liquefy. Lengthening the sheet pile, thus increasing the seepage path, is one effective method of accommodating seepage. For sheet pile walls that retain backfill, a drainage collector system is recommended. Some methods of seepage analysis are discussed in EM 1110-2-1901.

c. Wave action. The lateral forces produced by wave action are dependent on many factors, such as length, height, breaking point, frequency and depth at structure. Wave forces for a range of possible water levels should be determined in accordance with the U.S. Army Coastal Engineering Research Center Shore Protection Manual (USAEWES 1984).

4-6. Additional Applied Loads

Sheet Pile walls are widely used in many applications and can be subjected to a number of additional loads, other than lateral pressure exerted by soil and water.

a. Boat impact. Although it becomes impractical to design a sheet pile wall for impact by large vessels, waterfront structures can be struck by loose barges or smaller vessels propelled by winds or currents. Construction of a submerged berm that would ground a vessel will greatly reduce this possibility of impact. When the sheet pile structure is subject to docking impact, a fender system should be provided to absorb

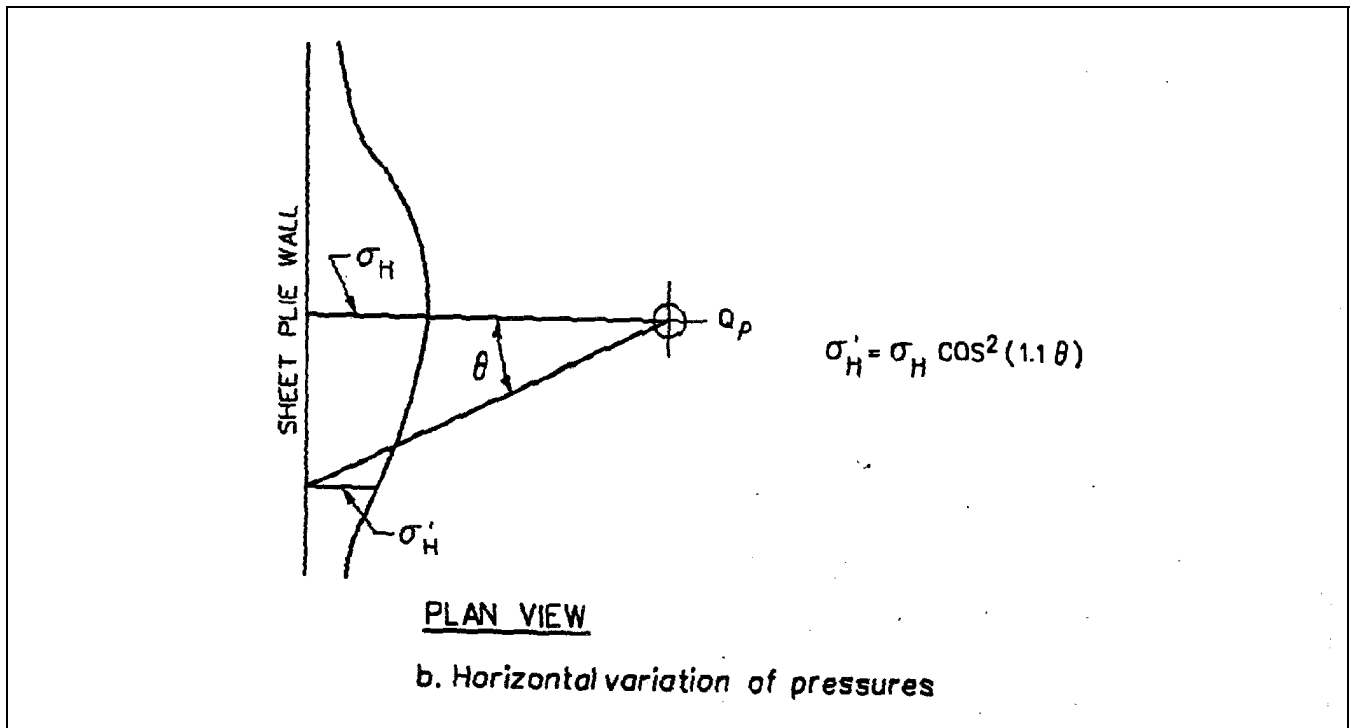
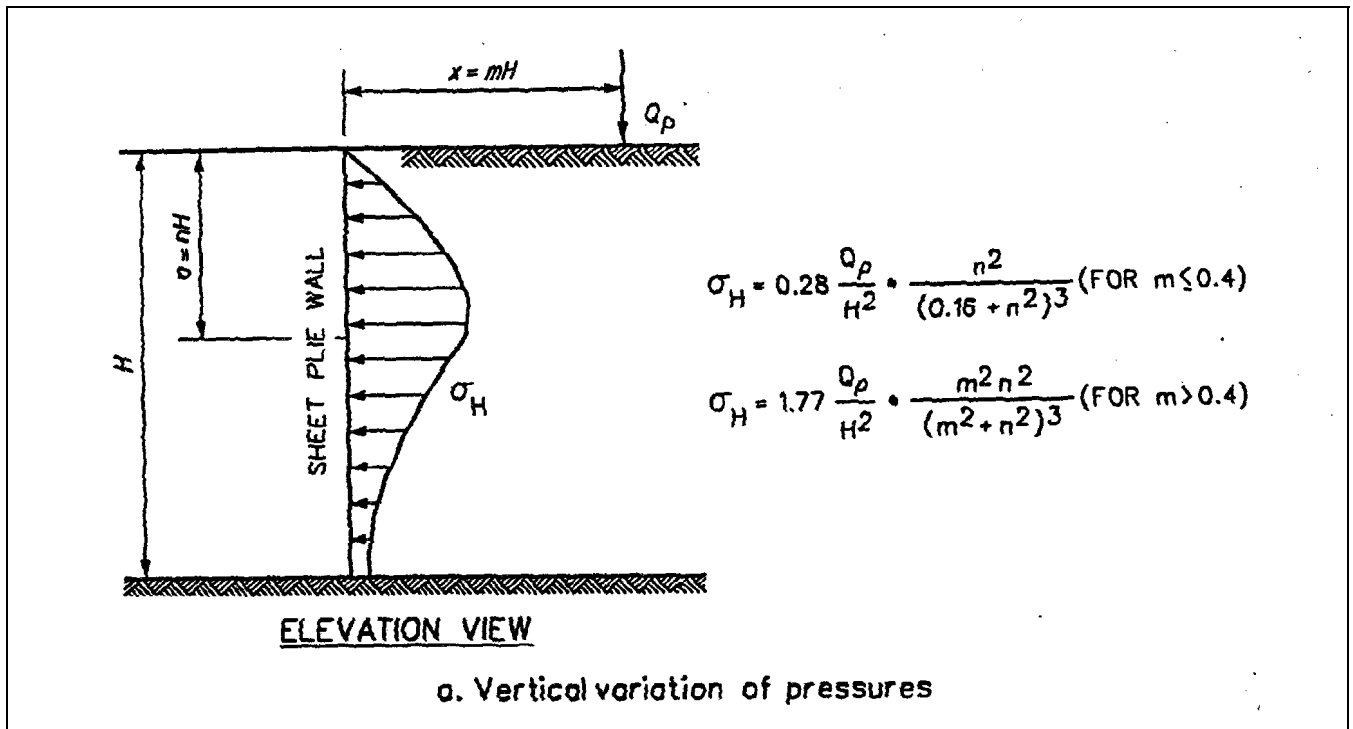

Figure 4-9. Point load (after Terzaghi 1954)

and spread the reaction. The designer should weigh the risk of impact and resulting damage as it applies to his situation. If conditions require the inclusion of either of these boat impact forces in the design, they should be evaluated based on the energy to be absorbed by the wall. The magnitude and location of the force transmitted to the wall will depend on the vessel's mass, approach velocity, and approach angle. Military Handbook 1025/1 (Department of the Navy 1987) provides excellent guidance in this area.

b. Mooring pulls. Lateral loads applied by a moored ship are dependent on the shape and orientation of the vessel, the wind pressure, and currents applied. Due to the use of strong synthetic lines, large forces can be developed. Therefore, it is recommended that mooring devices be designed independent of the sheet pile wall.

c. Ice forces. Ice can affect marine-type structures in many ways. Typically, lateral pressures are caused by impact of large floating ice masses or by expansion upon freezing. Expansive lateral pressures induced by water freezing in the backfill can be avoided by backfilling with a clean free-draining sand or gravel or installation of a drainage collector system. EM 1110-2-1612 should be references when the design is to include ice forces.

d. Wind forces. When sheet pile walls are constructed in exposed areas, wind forces should be considered during construction and throughout the life of the structure. For sheet pile walls with up to 20 feet of exposure and subjected to hurricanes or cyclones with basic winds speeds of up to 100 mph, a 50-pound per square foot (psf) design load is adequate. Under normal circumstances, for the same height of wall exposure, a 30-psf design load should be sufficient. For more severe conditions, wind load should be computed in accordance with American National Standards Institute (ANSI) A58.1 (ANSI 1982).

e. Earthquake forces. Earthquake forces should be considered in zones of seismic activity. The earth pressures should be determined in accordance with procedures outlined in EM 1110-2-2502 and presented in detail in the Ebeling and Morrison report on seismic design of waterfront retaining structures (Ebeling and Morrison 1992). In the worst case, the supporting soil may liquify allowing the unsupported wall to fail. This possibility should be evaluated and addressed in the design documentation. If accepting the risk and consequences of a liquefaction failure is unacceptable, consideration should be given to replacing or improving the liquefiable material or better yet, relocating the wall.

Chapter 5 System Stability

5-1. Modes of Failure

The loads exerted on wall/soil system tend to produce a variety of potential failure modes. These failure modes, the evaluation of the loads on the system, and selection of certain system parameters to prevent failure are discussed in this chapter.

a. Deep-seated failure. A potential rotational failure of an entire soil mass containing an anchored or cantilever wall is illustrated in Figure 5-1. This potential failure is independent of the structural characteristics of the wall and/or anchor. The adequacy of the system (i.e. factor of safety) against this mode of failure should be assessed by the geotechnical engineer through conventional analyses for slope stability (EM 1110-2-1902). This type of failure cannot be remedied by increasing the depth of penetration nor by repositioning the anchor. The only recourse when this type of failure is anticipated is to change the geometry of retained material or improve the soil strengths.

b. Rotational failure due to inadequate pile penetration. Lateral soil and/or water pressures exerted on the wall tend to cause rigid body rotation of a cantilever or anchored wall as illustrated in Figure 5-2. This type of failure is prevented by adequate penetration of the piling in a cantilever wall or by a proper combination of penetration and anchor position for an anchored wall.

c. Other failure modes. Failure of the system may be initiated by overstressing of the sheet piling and/or anchor components as illustrated in Figures 5-3 and 5-4. Design of the anchorage to preclude the failure depicted in Figure 5-4a is discussed later in this chapter. Design of the structural components of the system is discussed in Chapter 6.

5-2. Design for Rotational Stability

a. Assumptions. Rotational stability of a cantilever wall is governed by the depth of penetration of the piling or by a combination of penetration and anchor position for an anchored wall. Because of the complexity of behavior of the wall/soil system, a number of simplifying assumptions are employed in the classical design techniques. Foremost of these assumptions is that the deformations of the system are sufficient to produce limiting active and passive earth pressures at any point on the wall/soil interface. In the design of the

anchored wall, the anchor is assumed to prevent any lateral motion at the anchor elevation. Other assumptions are discussed in the following paragraphs.

b. Preliminary data. The following preliminary information must be established before design of the system can commence.

- (1) Elevation at the top of the sheet piling.
- (2) The ground surface profile extending to a minimum distance of 10 times the exposed height of the wall on either side.
- (3) The soil profile on each side of the wall including location and slope of subsurface layer boundaries, strength parameters (angle of internal friction ϕ , cohesive strength c , angle of wall friction δ , and wall/soil adhesion) and unit weight for each layer to a depth below the dredge line not less than five times the exposed height of the wall on each side.
- (4) Water elevation on each side of the wall and seepage characteristics.
- (5) Magnitudes and locations of surface surcharge loads.
- (6) Magnitudes and locations of external loads applied directly to the wall.

c. Load cases. The loads applied to a wall fluctuate during its service life. Consequently, several loading conditions must be defined within the context of the primary function of the wall. As a minimum, a cooperative effort among structural, geotechnical, and hydraulic engineers should identify the load cases outlined to be considered in the design.

(1) Usual conditions. The loads associated with this condition are those most frequently experienced by the system in performing its primary function throughout its service life. The loads may be of a long-term sustained nature or of an intermittent, but repetitive, nature. The fundamental design of the system should be optimized for these loads. Conservative factors of safety should be employed for this condition.

(2) Unusual conditions. Construction and/or maintenance operations may produce loads of infrequent occurrence and are short duration which exceed those of the usual condition. Wherever possible, the sequence of operations should be specified to limit the magnitudes

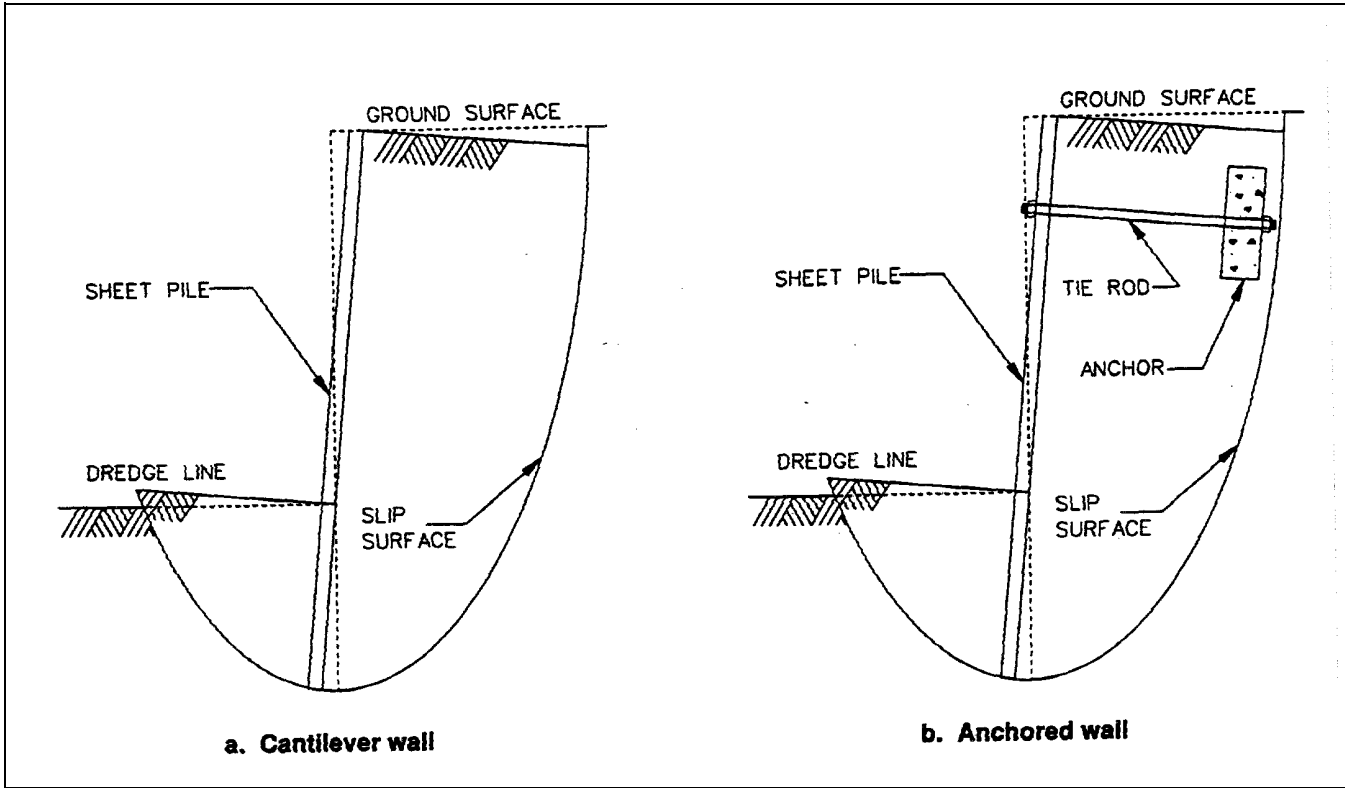

Figure 5-1. Deep-seated failure

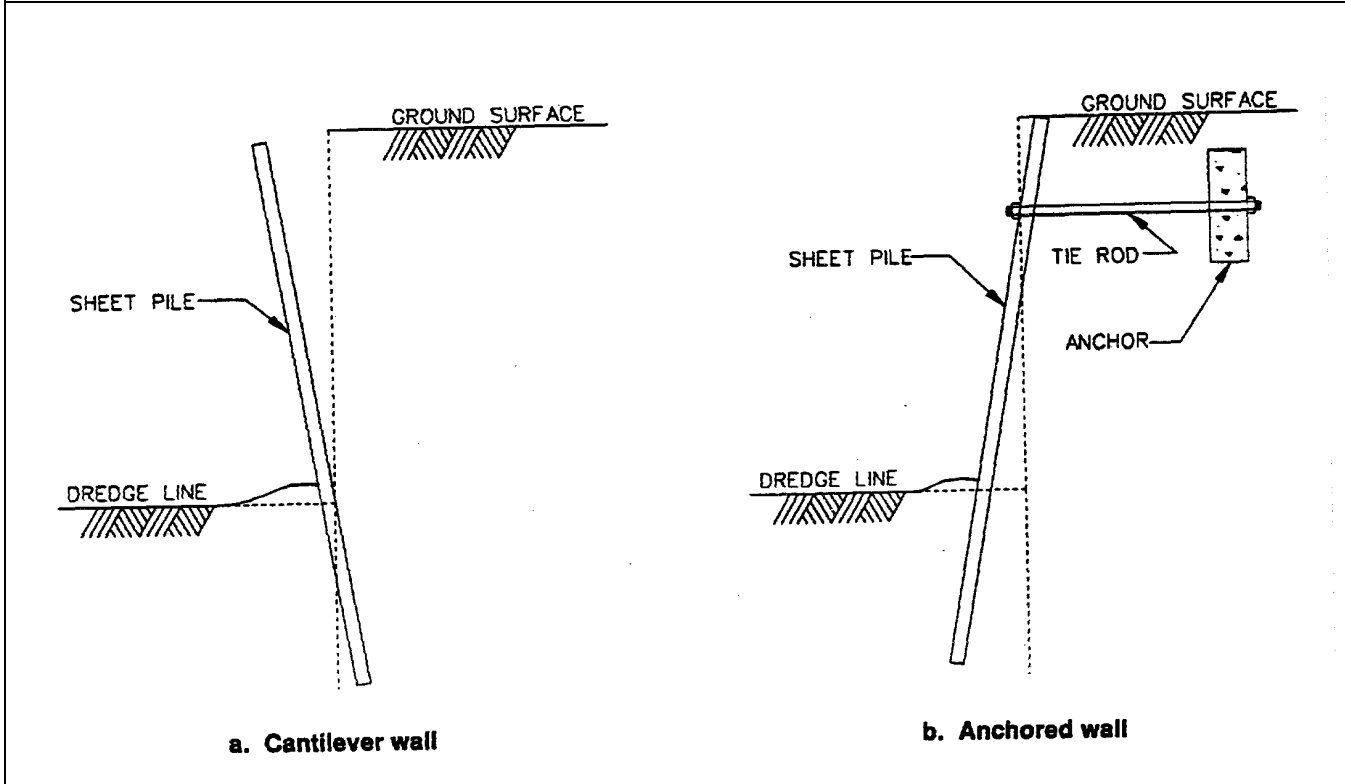

Figure 5-2. Rotational failure due to inadequate penetration

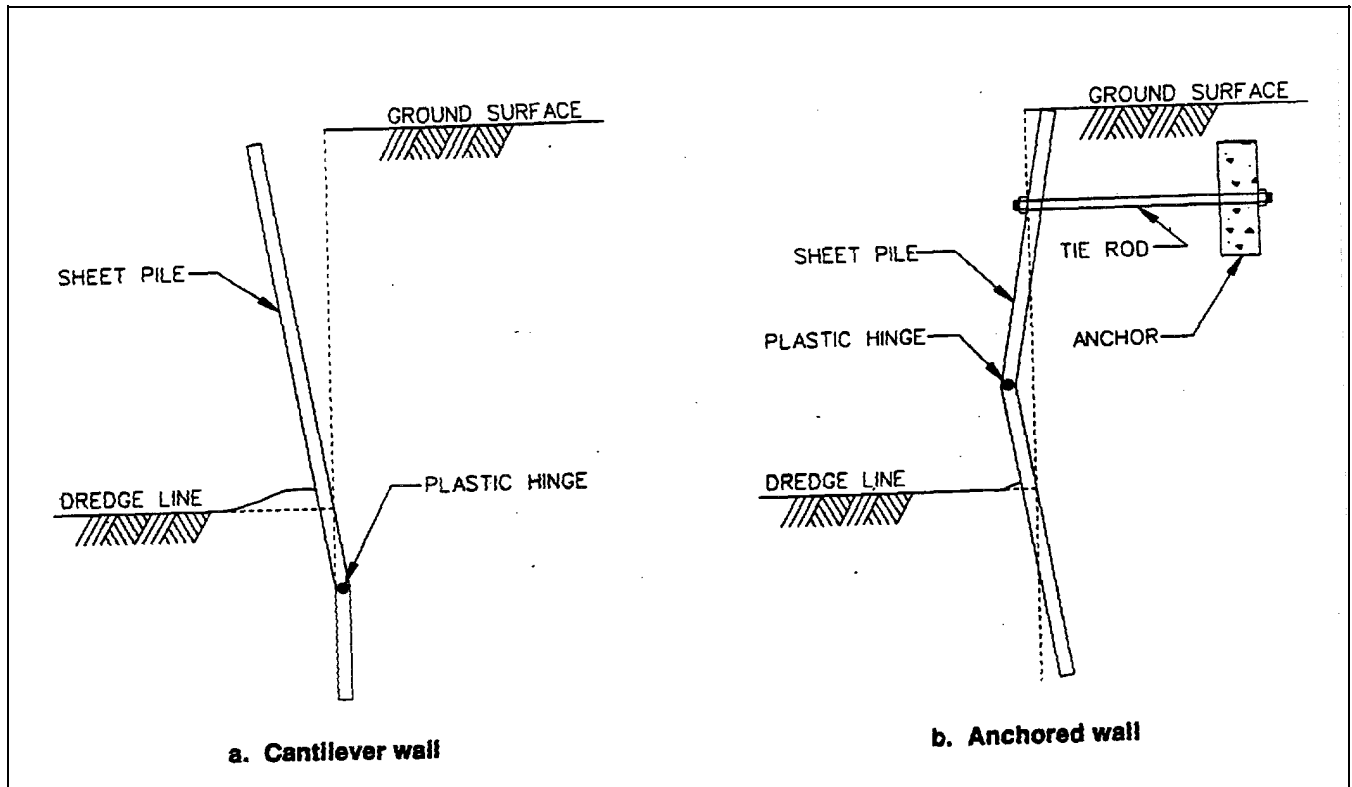

Figure 5-3. Flexural failure of sheet piling

and duration of loading, and the performance of the wall should be carefully monitored to prevent permanent damage. Lower factors of safety or higher material stresses may be used for these conditions with the intent that the system should experience no more than cosmetic damage.

(3) Extreme conditions. A worst-case scenario representing the widest deviation from the usual loading condition should be used to assess the loads for this case. The design should allow the system to sustain these loads without experiencing catastrophic collapse but with the acceptance of possible major damage which requires rehabilitation or replacement. To contrast usual and extreme conditions, the effects of a hurricane on a hurricane protection wall would be the "usual" condition governing the design, while the loads of the same hurricane on an embankment retaining wall would be "extreme."

d. *Factors of safety for stability.* A variety of methods for introducing "factors of safety" into the design process have been proposed; however, no universal procedure has emerged. In general, the design should contain a degree of conservatism consistent with

the experience of the designer and the reliability of the values assigned to the various system parameters. A procedure which has gained acceptance in the Corps of Engineers is to apply a factor of safety (strength reduction factor) to the soil strength parameters ϕ and c while using "best estimates" for other quantities. Because passive pressures calculated by the procedures described in Chapter 4 are less likely to be fully developed than active pressures on the retaining side, the current practice is to evaluate passive pressures using "effective" values of ϕ and c given by

$$\tan(\phi_{\text{eff}}) = \tan(\phi) / \text{FSP} \quad (5-1)$$

and

$$c_{\text{eff}} = c / \text{FSP} \quad (5-2)$$

where

FSP = factor of safety for passive pressures

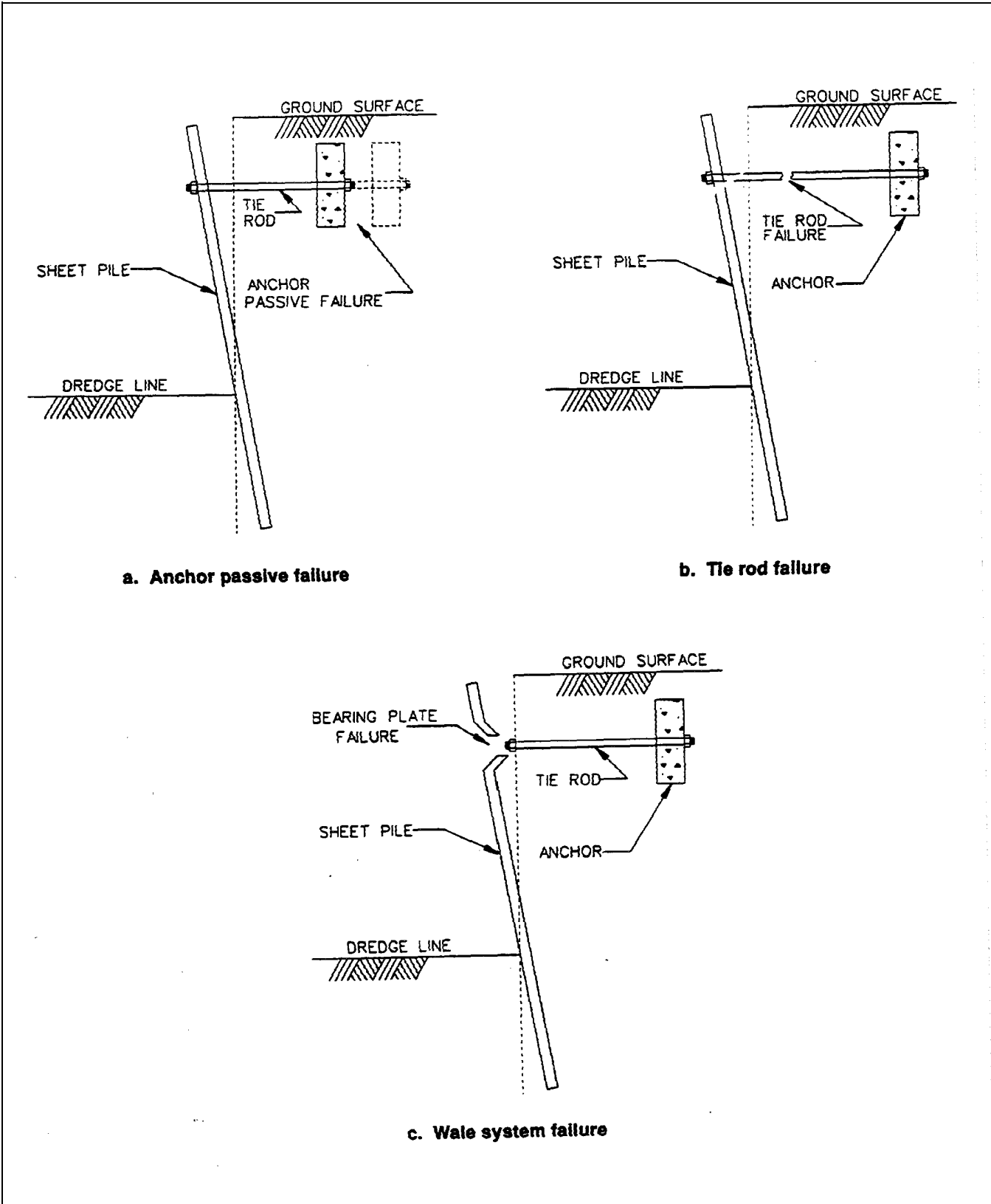

Figure 5-4. Anchorage failures

Minimum recommended values of FSP are given in Table 5-1. A factor of safety FSA may be applied for active pressures, however it is considered sufficient to use an FSA = 1 in most cases unless deformations of the wall are restricted.

Table 5-1
Minimum Safety Factors for Determining the Depth of Penetration Applied to the Passive Pressures

| Loading Case | Fine-Grain Soils | Free-Draining Soils |
|------------------------|----------------------------|---------------------|
| Floodwalls | | |
| Usual | 1.50 Q-Case 1.10 S-Case | 1.50 S-Case |
| Unusual | 1.25 Q-Case 1.10 S-Case | 1.25 S-Case |
| Extreme | 1.10 Q-Case 1.10 S-Case | 1.10 S-Case |
| Retaining Walls | | |
| Usual | 2.00 Q-Case 1.50 S-Case | 1.50 S-Case |
| Unusual | 1.75 Q-Case 1.25 S-Case | 1.25 S-Case |
| Extreme | 1.50 Q-Case 1.10 S-Case | 1.10 S-Case |

e. Net pressure distributions. Evaluations of the pressures by the processes described in Chapter 4 result in a number of pressure distributions.

- (1) Active soil pressures due to retained side soil.
- (2) Passive soil pressures due to retained side soil.
- (3) Pressures due to surcharge loads on retained side surface. (Effects of surcharge loads are included in the soil pressures when a wedge method is used.)
- (4) Active soil pressures due to dredge side soil.
- (5) Passive soil pressures due to dredge side soil.
- (6) Pressures due to surcharge loads on dredge side surface.
- (7) Net water pressures due to differential head.

For convenience in calculations for stability, the individual distributions are combined into "net" pressure distributions according to:

"NET ACTIVE" PRESSURE = retained side active soil pressure
 - dredge side passive soil pressure
 + net water pressure
 (+ pressure due to retained side surcharge)
 (- pressure due to dredge side surcharge)

"NET PASSIVE" PRESSURE = retained side passive soil pressure
 - dredge side active soil pressure
 + net water pressure
 (+ pressure due to retained side surcharge)
 (- pressure due to dredge side surcharge)

In these definitions of net pressure distributions, positive pressures tend to move the wall toward the dredge side. Typical net pressure diagrams are illustrated in Figure 5-5.

f. Stability design for cantilever walls. It is assumed that a cantilever wall rotates as a rigid body about some point in its embedded length as illustrated in Figure 5-2a. This assumption implies that the wall is subjected to the net active pressure distribution from the top of the wall down to a point (subsequently called the "transition point") near the point of zero displacement. The design pressure distribution is then assumed to vary linearly from the net active pressure at the transition point to the full net passive pressure at the bottom of the wall. The design pressure distribution is illustrated in Figure 5-6. Equilibrium of the wall requires that the sum of horizontal forces and the sum of moments about any point must both be equal to zero. The two equilibrium equations may be solved for the location of the transition point (i.e. the distance z in Figure 5-6) and the required depth of penetration (distance d in Figure 5-6). Because the simultaneous equations are non-linear in z and d , a trial and error solution is required.

g. Stability design for anchored walls. Several methods for anchored wall design have been proposed

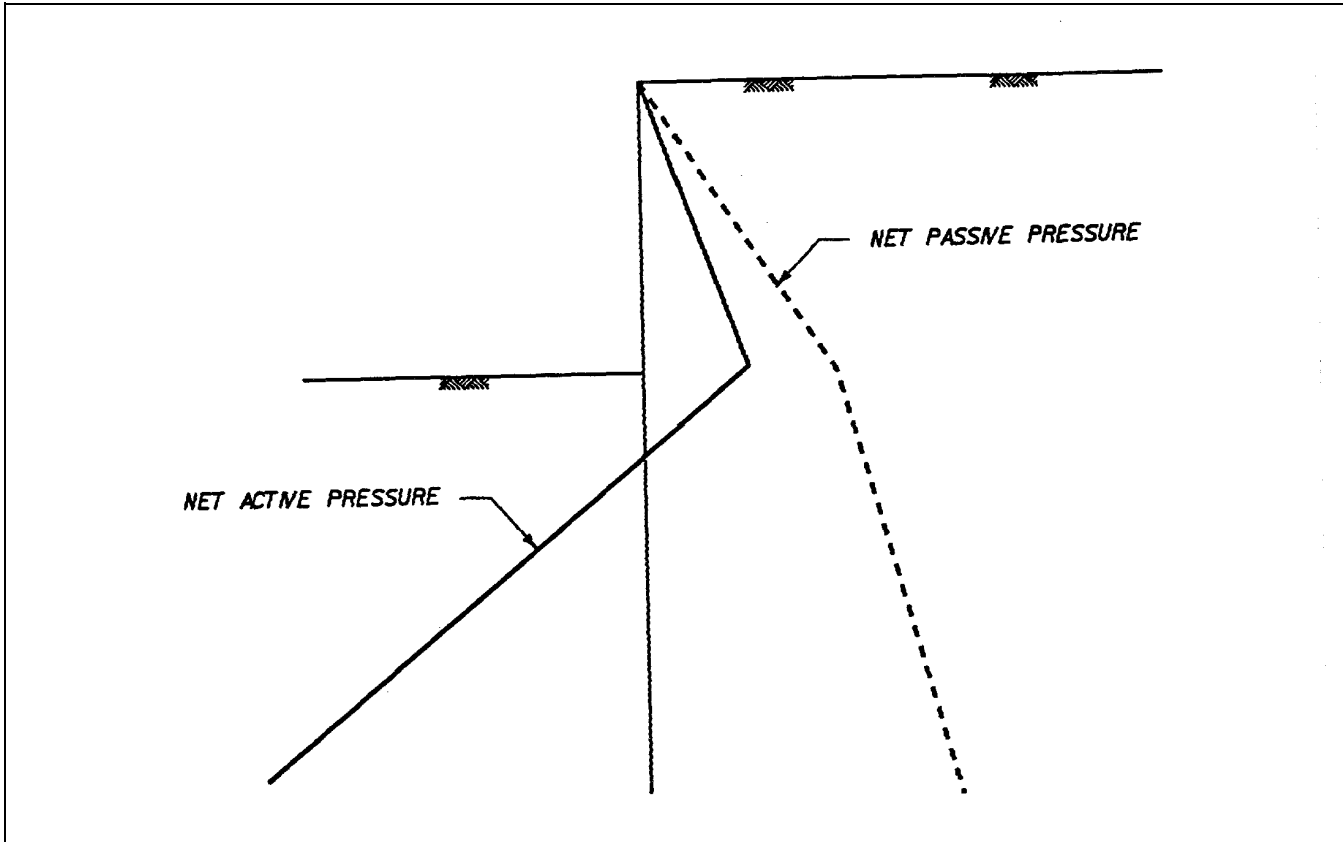

Figure 5-5. Typical net pressure distributions

and classified as the "Free Earth" method (implied in Figure 5-2b) and variations of the "Fixed Earth" hypothesis. Research and experience over the years have shown that walls designed by the Free Earth method are sufficiently stable walls with less penetration than those designed by the Fixed Earth method. Because of the flexibility of the sheet piling, the Free Earth method predicts larger moments than those that actually occur. This shortcoming of the Free Earth method is overcome by using Rowe's moment reduction curves, as described in Chapter 6. In the Free Earth method, the anchor is assumed to be a rigid simple support about which the wall rotates as a rigid body as shown in Figure 5-2b. Despite the tendency of the wall to produce a passive condition in the retained soil above the anchor, it is assumed that the wall is only subjected to the net active pressure distribution as illustrated in Figure 5-7. The required depth of penetration (d in Figure 5-7) is determined from the equilibrium requirement that the sum of moments about the anchor must be zero. After the depth of penetration has been determined, the anchor force is obtained from equilibrium of horizontal forces. Because the position of the anchor affects both depth of

penetration and anchor force, it will be necessary to consider several anchor positions to arrive at the optimal combination. For an initial estimate, the anchor may be assumed to lie at a distance below the top of the wall equal to one-fourth to one-third of the exposed wall height.

h. Anchor design. The anchor force calculated in the stability analysis was obtained from equilibrium of a typical 1-foot slice of the wall. In the actual system the anchor support is provided by discrete tie rods attached to the wall through wales and to another support mechanism (termed the "anchor" herein) at their ends and remote from the wall. Structural design of the tie rods and wales is discussed in Chapter 6. A variety of anchor configurations are illustrated in Figure 2-2. Capacities of some anchor configurations are discussed in the following paragraphs. The soil strength parameters appearing in the equations associated with anchor design should be consistent with the properties (S-case or Q-case) used for stability design. In all cases the capacity of the anchor should be sufficient to develop the yield strength of the tie rods (Chapter 6).

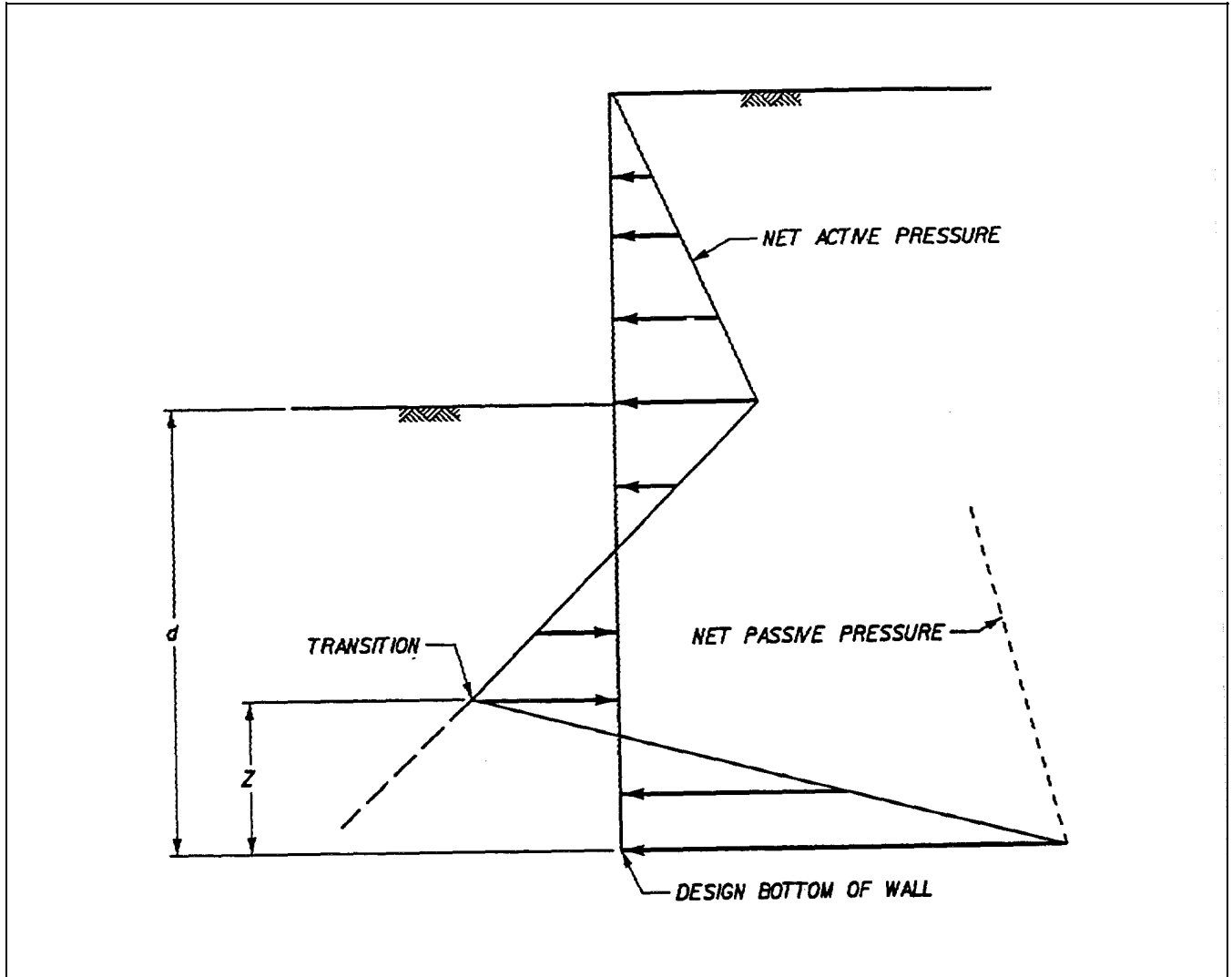

Figure 5-6. Design pressure distribution for cantilever wall

(1) Continuous anchors. A continuous anchor consists of a sheet pile or concrete wall installed parallel to the retaining wall as illustrated in Figures 2-2a and 2-2b. The continuous anchor derives its resistance from differential passive and active pressures produced by interaction with the surrounding soil.

(a) Anchor location. The minimum distance from the retaining wall at which an anchor wall must be placed to develop its full capacity is illustrated in Figure 5-8 for a homogeneous soil system. Under the assumptions employed in the stability analysis of the retaining wall, a zone of soil (bounded by line ab in Figure 5-8) behind the retaining wall is at its limiting active state. To permit development of passive pressures, an additional zone of soil (bounded by line bc in

Figure 5-8) must be available. In addition, if the anchor wall intersects the line ac in Figure 5-8, interaction between the anchor wall and the retaining wall may increase the soil pressures on the retaining wall, thus invalidating the previous stability analysis. For non-homogeneous soil systems, the boundaries defining minimum spacing of the anchor wall may be estimated by the procedures used in the "Fixed Surface" wedge method described in CWALSHT User's Guide (USAEWES 1990).

(b) Full anchor capacity. Active and passive pressures developed on the anchor wall are shown in Figure 5-9 for a homogeneous soil system where h/H is $1/3$ to $1/2$ (Teng (1962) and Terzaghi (1943)). The capacity of the anchor wall is given by

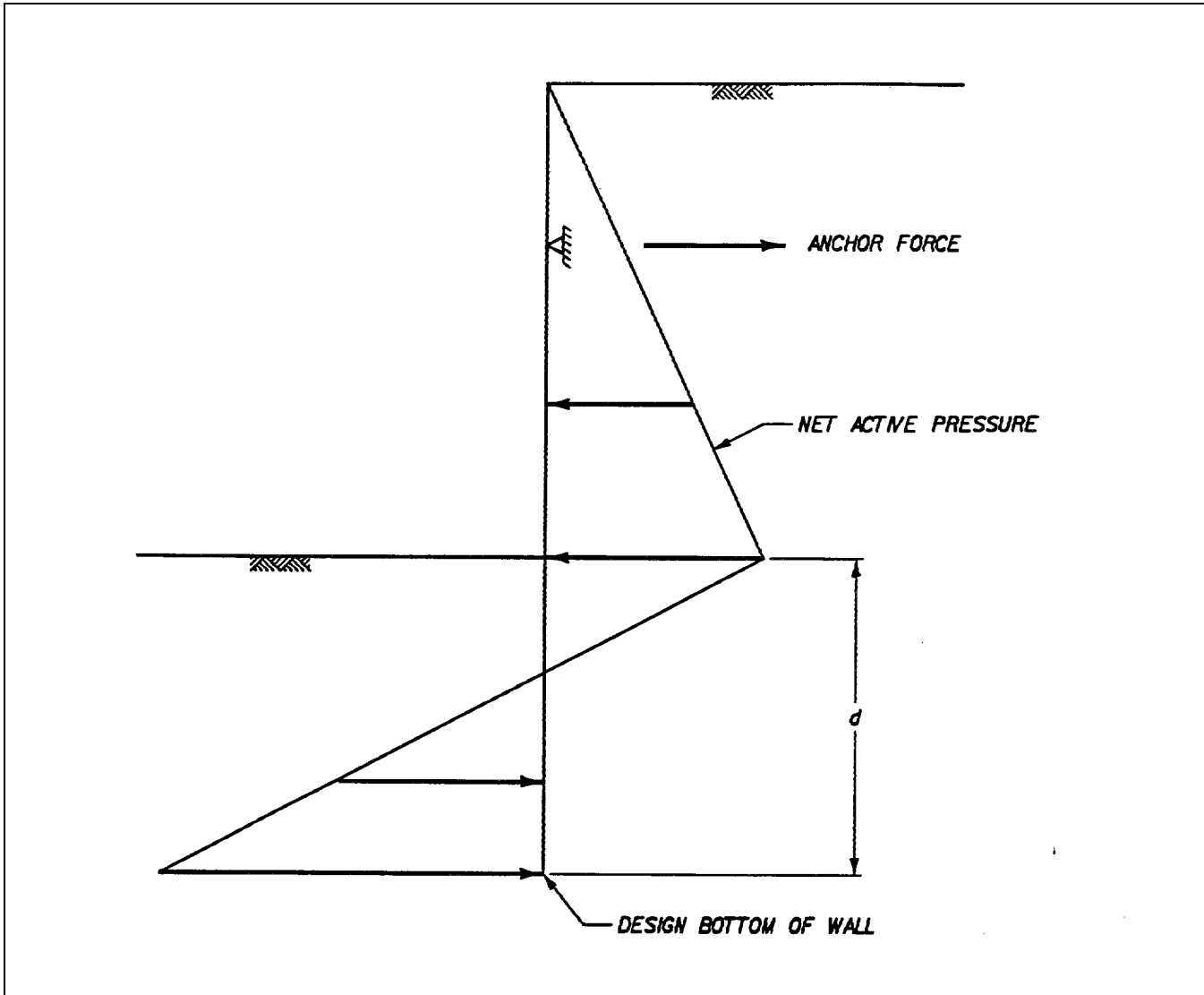

Figure 5-7. Design pressure distribution for free earth design of anchored walls

$$C_a = P_p - P_A \quad (5-3)$$

$$P_p = \gamma H^2 K_p / 2 \quad (5-4)$$

where

and

C_a = anchor wall capacity per foot of anchor wall

$$P_A = \gamma H^2 K_A / 2 \quad (5-5)$$

P_p = resultant of the passive pressures in front of the anchor wall

P_A = resultant of the active pressures in back of the anchor wall

where K_p and K_A are passive and active earth pressure coefficients given in Equations 4-3 and 4-4 evaluated with the same effective angle of internal friction used for stability analysis of the retaining wall but with zero wall friction. For homogeneous soils with Q-case strength parameters, ($K_A = K_p = 1$)

For homogeneous soils with S-case strengths

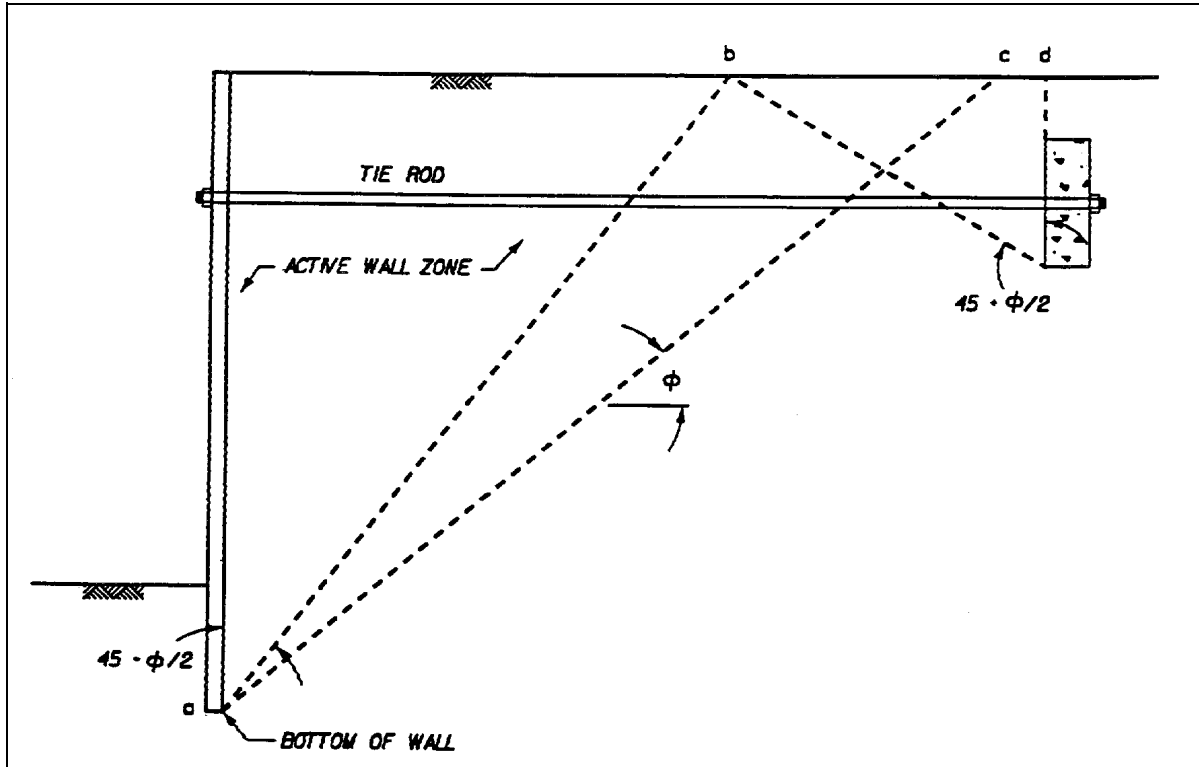

Figure 5-8. Minimum anchor - wall spacing for full passive anchor resistance in homogeneous soil

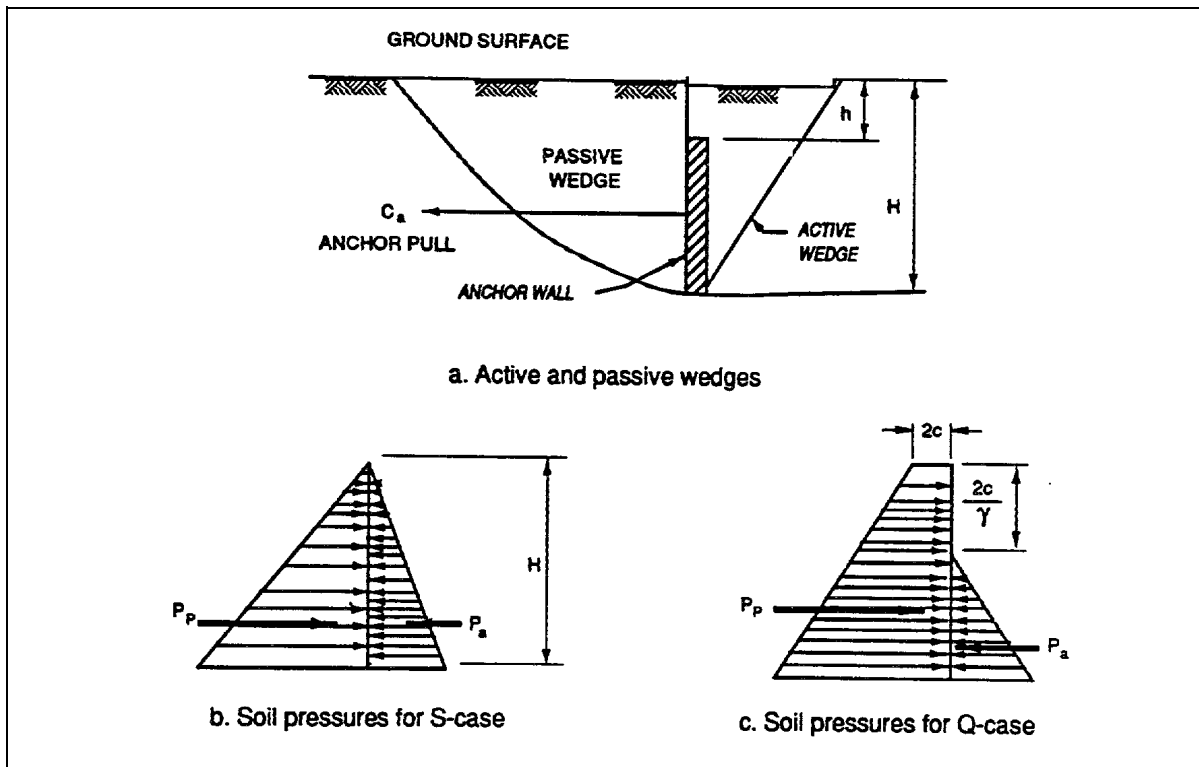

Figure 5-9. Resistance of continuous anchor wall

$$P_p = \frac{\gamma H^2}{2} + 2c_H \quad (5-6)$$

and

$$P_A = \frac{\gamma H^2}{2} - 2c_H + \frac{2c^2}{\gamma} \quad (5-7)$$

where c is the effective soil cohesive strength used for stability analysis of the retaining wall.

(c) Reduced anchor wall capacity. When physical constraints require violation of the minimum spacing between anchor wall and retaining wall, the attendant reduced anchor wall capacity should be evaluated by the procedures discussed by Terzaghi (1934).

(d) Structural design of sheet pile and concrete anchor walls. Sheet pile anchor walls should be designed for maximum bending moment and shear under the stress limitations delineated in Chapter 6. Concrete anchors should be designed under the American Concrete Institute (ACI) 318 (1983) specifications for concrete structure in contact with the earth.

(2) Discontinuous anchors. Discontinuous anchors (or dead men) are usually composed of relatively short walls or blocks of concrete. The stress distribution ahead of a dead man is illustrated in Figure 5-10a and a free-body diagram is shown in Figure 5-10b. The capacity of a dead man near the ground surface for S-case strengths ($c = 0$) may be taken as

$$C_a = L(P_p - P_A) + (1/3) K_o \gamma \left(\sqrt{K_p} + \sqrt{K_A} \right) H^3 \tan(\phi) + W \tan(\phi) \quad (5-8)$$

and for Q-case strengths, ($\phi = 0$)

$$C_a = L(P_p - P_A) + 2cH^2 + LBc \quad (5-9)$$

where

L = length of the dead man parallel to the retaining wall

B = thickness of the deadman perpendicular to the retaining wall

P_A and P_p = resultants of active and passive soil pressures (Equations 5-4 through 5-7), respectively

ϕ and c = effective (factored) angle of internal friction and cohesive strength, respectively

K_p and K_A = passive and active earth pressure coefficients evaluated for effective strengths (Equations 4.3 and 4.4)

K_o = at-rest pressure coefficient which may be taken as

$$K_o = 1 - \sin(\phi) \quad (5-10)$$

(3) Anchors at large depth. Capacities of anchors at large depth below the ground surface may be taken as the bearing capacity of a footing located at a depth equal to the midheight of the anchor (Terzaghi 1943).

(4) Grouted anchorage. Grouted anchorage consists of tie rods or tendons installed in cased, drilled holes with their remote ends grouted into competent soil or rock as illustrated in Figures 2-2c and 5. The grouted length must be fully outside the active wall zone (line ab in Figure 5-5). Tie rods must be designed to resist the anchor force determined from wall stability analysis plus any preload applied for alignment or limitation of initial deflections. The capacity of all grouted anchors, which should develop the yield strength of the tie rod, must be verified by proof tests by loading to 110 percent of their required resistance. At least two anchors should be subjected to performance tests by loading to 150 percent of their design capacity.

(5) Pile anchors. Capacities of anchors composed of tension piles or pile groups, Figure 2-2, should be evaluated by the procedures set forth in EM 1110-2-2906.

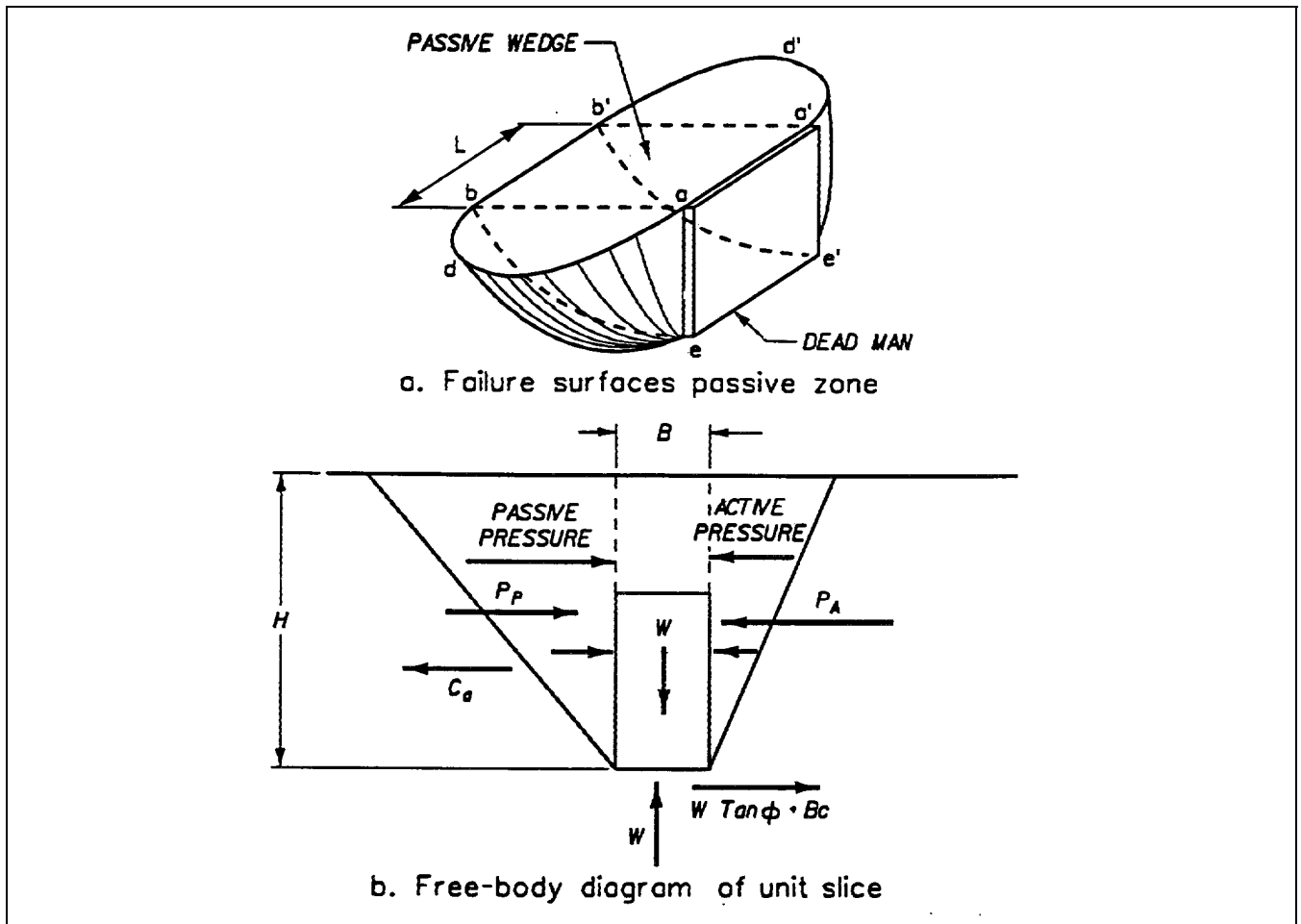

Figure 5-10. Resistance of discontinuous anchor (dead man)

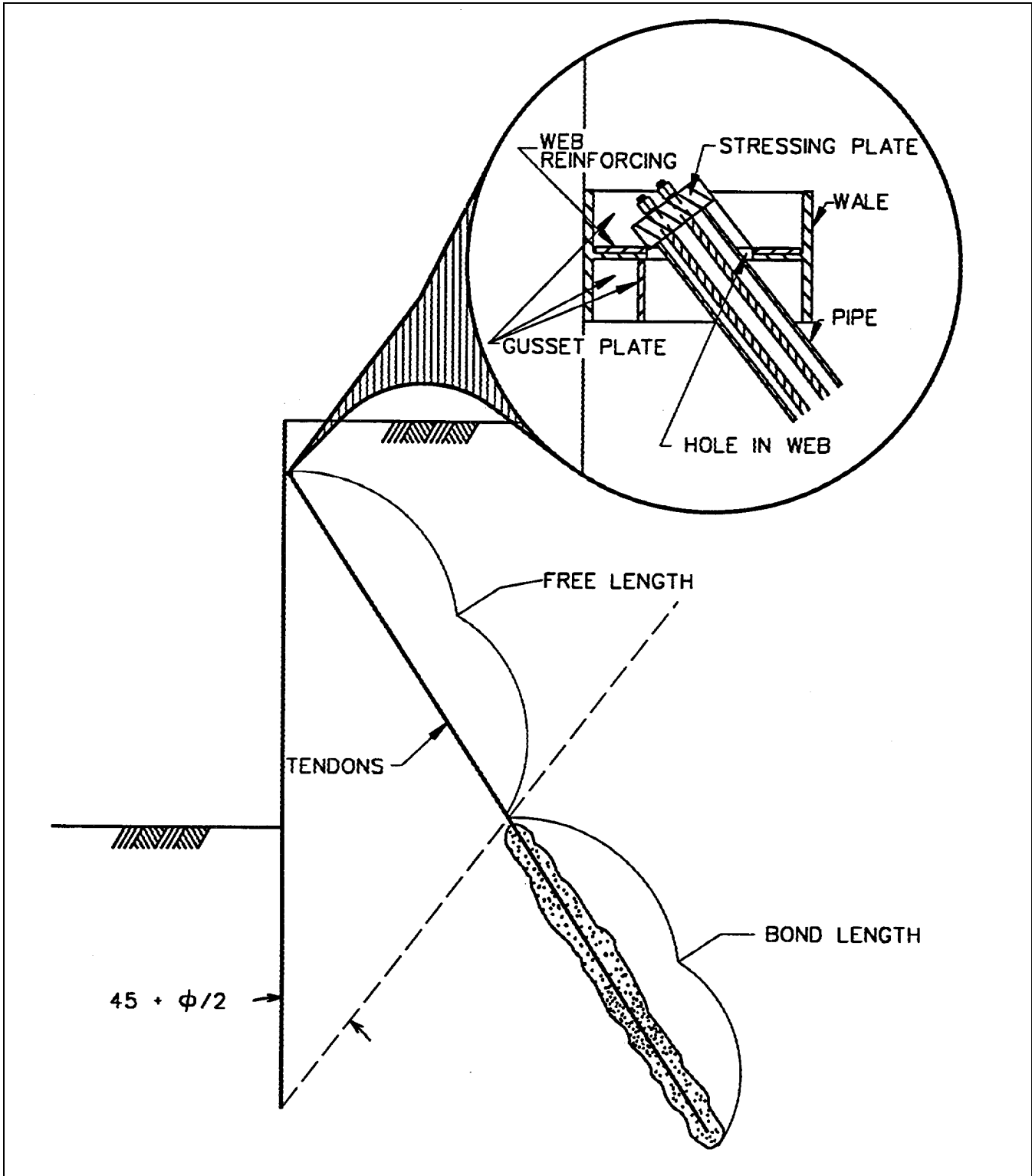

Figure 5-11. Grouted anchors

Chapter 6 Structural Design

6-1. Forces for Design

Design penetration of the piling is based on a factor of safety for stability applied to soil strengths. To avoid compounding factors of safety, the sheet piling and wales are designed to resist forces produced by soil pressures calculated using a factor of safety of 1 for both active and passive pressures. Consequently, the analyses for soil pressures (Chapter 4) and system stability (Chapter 5) must be repeated with full soil strength properties including consideration of usual, unusual, and extreme loading conditions. The sizes of the sheet piling and wales are determined from the net pressure distributions, depth of penetration, and assumed structural supports as illustrated in Figures 6-1 and 6-2.

a. Cantilever wall. Bending moments and shears are calculated under the assumption that the wall is a cantilever beam fixed at the bottom of the wall, Figure 6-1.

b. Anchored wall.

(1) Structural analysis. Bending moments, shears, and anchor force are calculated under the assumption that the wall is a beam with simple supports at the anchor elevation and at the bottom of the wall (Figure 6-2). With the bottom of the wall at the penetration consistent with a factor of safety of 1, the lateral reaction at the bottom support will be zero and the lateral reaction at the upper support will be the horizontal component of the anchor force.

(2) Total anchor force. When the tie rods are installed perpendicular to the plane of the wall, the design tie rod force will be equal to the lateral reaction at the upper support (Figure 6-2). When the tie rods are inclined, Figures 5-11 and 6-3, the total tie rod force is obtained from

$$T_A = T_{\Delta H} / \cos(\alpha) \quad (6-1)$$

where

$T_{\Delta H}$ = upper simple support reaction

α = angle of tie rod inclination

Tie rod inclination further induces axial force in the sheet piling given by

$$T_{\Delta V} = T_{\Delta H} \tan(\alpha) \quad (6-2)$$

The axial component of inclined anchor force and any external axial loads are assumed to be resisted by a vertical reaction at the lower simple support.

6-2. Deflections

When the material and cross section for the piling have been selected, structural deflections are calculated using the assumed support conditions shown in Figures 6-1 and 6-2. It must be emphasized that the deflections thus determined are representative of the relative deformation of the wall. Total system displacements will be comprised of a combination of structural deformations and rotations and translations of the entire wall/soil system.

6-3. Design of Sheet Piling

The structural analyses described in paragraph 6-1 provide values of maximum bending moment (Mmax), maximum shear (Vmax), and anchor force per foot of wall to be sustained by the piling.

a. Materials and allowable stresses for sheet piling.

(1) Steel. Allowable stresses for steel sheet piling for usual load conditions are:

$$\begin{aligned} \text{Combined bending and axial load: } f_b &= 0.5 f_y \\ \text{Shear: } f_v &= 0.33 f_y \end{aligned}$$

where f_y is the yield stress of the steel. The 0.5 times f_y for combined bending and axial load represents 5/6 of the American Institute of Steel Construction (AISC) recommended values and reflects the Corps' design procedures for hydraulic steel structures. For unusual loadings the allowable stresses may be increased by 33 percent. For extreme loadings the allowable stresses may be increased by 75 percent.

(2) Prestressed concrete piles. Design must satisfy both strength and serviceability requirements. Strength design should follow the basic criteria set forth in ACI 318 (1983), except the strength reduction factor (ϕ) shall be 0.7 for all failure modes and a single load factor for 1.9 shall be used for all loads. The specified load and strength reduction factors provide a safety factor equal

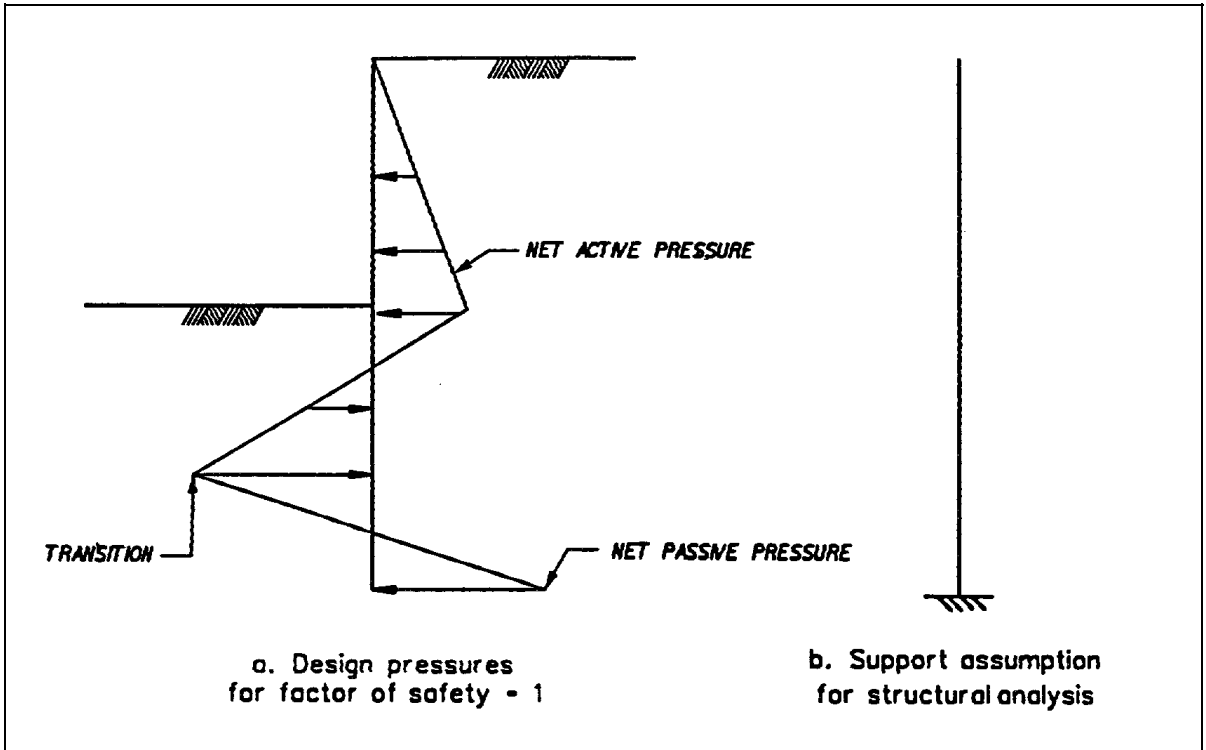

Figure 6-1. Pressures and supports for structural design of cantilever walls

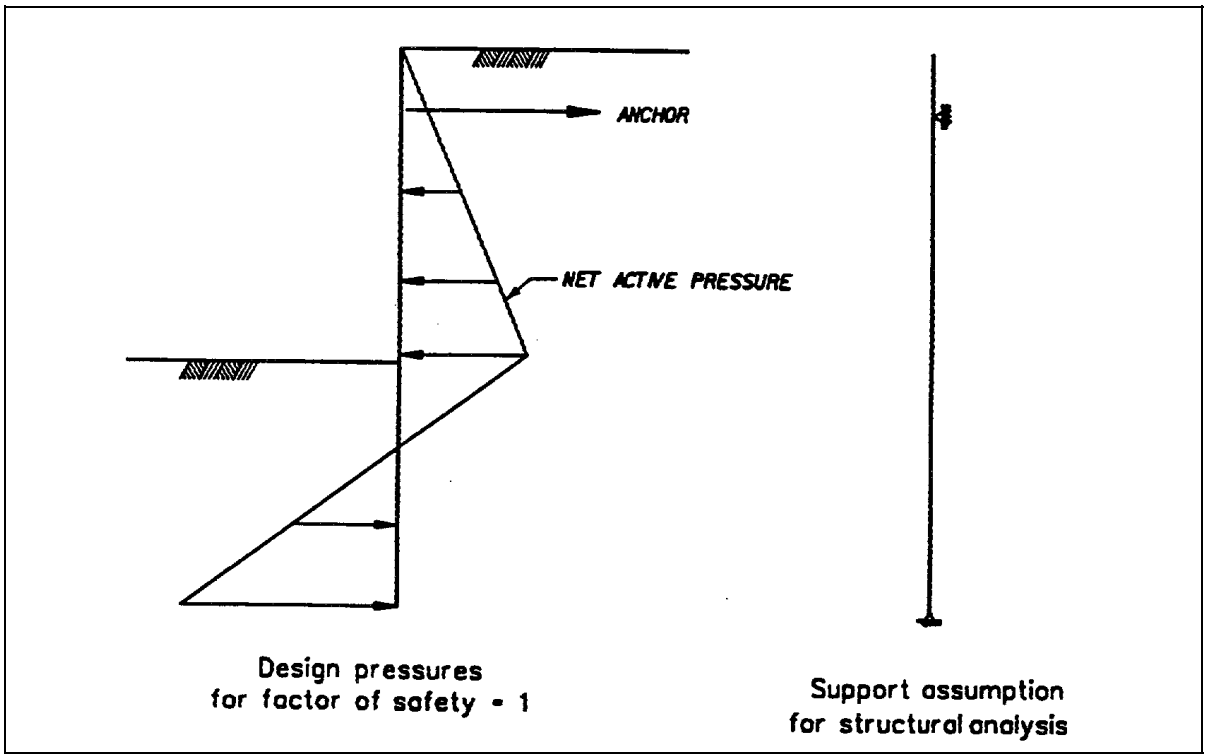

Figure 6-2. Pressures and supports for structural design of anchored walls

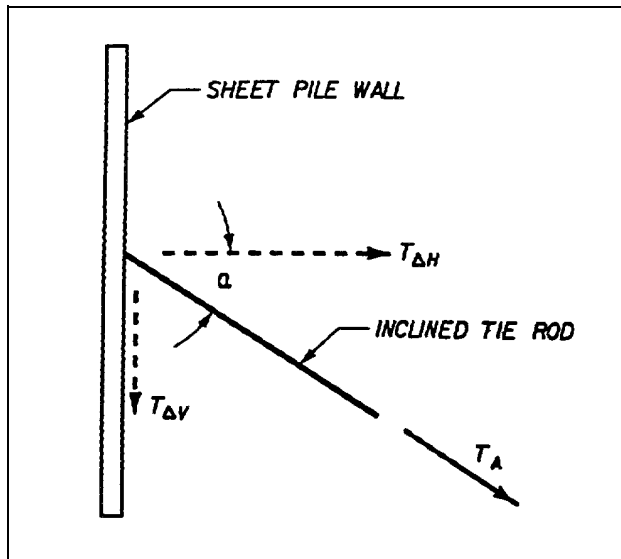

Figure 6-3. Anchor force components for inclined anchors

to 2.7. Control of cracking in prestressed piles is achieved by limiting the concrete compressive and tensile stresses, under service load conditions, to the following values:

| | |
|--------------------------|-------------|
| Uniform Axial Tension | 0 |
| Bending (Extreme Fibers) | |
| Compression | $0.40 f'_c$ |
| Tension | 0 |

f'_c = compressive strength of concrete

(3) Reinforced concrete. Reinforced concrete piles shall be designed in accordance with EM 1110-2-2104.

(4) Aluminum. Basic allowable stresses for aluminum piles will be the lesser of the minimum yield strength divided by a factor of safety of 1.95 or the minimum ultimate tensile strength divided by a factor of safety of 2.3. Additional information can be found in the latest edition of the Aluminum Association's "Specifications for Aluminum Structures" (1976).

(5) Wood. Stresses for wood piles should be in accordance with "The National Design Specification for Wood Construction" (National Forest Products Association 1986), depending on species and grade.

(6) Other materials. Sheet piles composed of fiberglass, vinyl, and PVC are usually available as very flexible sections with low moment capacities. Their

use should be limited to very low wall heights subjected to light loads. Sectional geometries and material properties should be specified for each application, and conformance of the piling should be verified by a qualified testing laboratory. As a minimum, the designer should specify acceptable values of the following properties determined by the referenced ASTM standards: water absorption (ASTM D 570 (1981)); tensile strength (ASTM D 638 (1989d)); flexural strength and modulus of elasticity (ASTM D 790 (1986b)); compressive strength (ASTM D 695 (1990)); and barcol hardness (ASTM D 2583 (1987)). If a wall of these materials is expected to be exposed to sunlight or extreme heat, the ultraviolet and thermal properties of the material should be investigated and adequate protection provided.

b. Material selection. Selection of the material for the sheet piling should be based on economics, aesthetics, the function of the wall, and the difficulty of installation. Life cycle cost analyses should be performed for various alternatives to select the most viable solution. Steel is the most frequently used material because of its relatively high strength-weight ratio and its availability in a variety of shapes and sizes. Aluminum piling may be advantageous in a corrosive environment where additional thickness of steel is required to compensate for section loss.

c. Required pile cross section for cantilever walls. The sheet pile section must provide the following minimum sectional properties after allowance for possible loss of material due to corrosion, abrasion, or other detrimental effects.

(1) Cantilever walls of materials other than concrete.

(a) Flexure. The minimum section modulus is given by

$$S_{\min} = M_{\max} / f_b \quad (6-3)$$

where

S_{\min} = section modulus per foot of wall

M_{\max} = maximum bending moment per foot of wall

f_b = allowable bending stress appropriate to the material and loading condition

(b) Shear. The minimum "shear area" is given by

$$A_{v,\min} = V_{\max} / f_v \quad (6-4)$$

where

$A_{v,\min}$ = minimum "shear area" per foot of wall

V_{\max} = maximum shear per foot of wall

f_v = allowable shear stress appropriate to the material and loading condition

The shear area for Z-shaped sections may be taken as

$$A_v = t_w h / w \quad (6-5)$$

where

t_w = thickness of the web portion of the Z

h = height of the Z

w = width of the section

For wood piles the shear area may taken as two-thirds of the rectangular area per foot of wall.

(c) Combined loads. Where external effects (e.g. a concrete cap) may produce an axial load in the pile, the minimum section modulus is given by

$$S_{\min} = [M_{\max} + P(y_p + e_p)] / f_b \quad (6-6)$$

where

P = applied axial load

y_p = lateral deflection at the point of application of P

e_p = eccentricity of the point of application of P from the centroidal axis of the piling (may be positive or negative)

It is recommended that the value of $P(y_p + e_p)$ be less than $M_{\max}/10$ unless it is demonstrated that buckling of the piling is unlikely.

(2) Cantilever concrete walls. Cross sections for walls of prestressed or reinforced concrete shall be proportioned for maximum bending moment, shear and any axial load in accordance with paragraphs 6-3a(2) and (3).

d. Required cross section for anchored walls. The pile section must provide the minimum sectional properties after allowance for loss of material due to corrosion, abrasion, and other deleterious effects.

(1) Moment reduction for anchored walls. Rowe (1952, 1955a and b, 1956, 1957a and b) demonstrated that the Free Earth method overestimates the maximum bending moment in anchored walls with horizontal tie rods. The reduced bending moment for design is given by

$$M_{des} = M_{\max} R_m \quad (6-7)$$

where

M_{\max} = maximum bending moment predicted by the Free Earth method

R_m = reduction factor depending on wall geometry, wall flexibility, and foundation soil characteristics

(a) Moment reduction factor for granular foundation soils. When the soil below the dredge line is granular, the magnitude of the reduction factor R_m is a function of a flexibility number given by

$$\rho = H^4 / EI \quad (6-8)$$

where

H = total length of the sheet piling (ft)

E = modulus of elasticity of the pile material (psi)

I = moment of inertia (in⁴) per foot of wall

Curves of R_m are given in Figure 6-4 for "loose" and "dense" foundation material and several system geometries.

(b) Moment reduction factor for cohesive foundation soils. Moment reduction factors for piles in homogeneous cohesive soils also depend on the stability number given by

$$S_n = 1.25 (c/p_v) \quad (6-9)$$

where

c = cohesive strength of the soil

p_v = effective vertical soil pressure on the retained side of the wall at the elevation of the dredge line

Curves for R_m are given for various combinations of system parameters in Figure 6-4.

(2) Anchored walls of materials other than concrete.

(a) Flexure. The minimum required section modulus is given by

$$S_{\min} = [M_{des} + T_{av}(y_m + e_a)]/f_b \quad (6-10)$$

where

M_{des} = reduced maximum bending moment

T_{av} = axial component of an inclined anchor force

y_m = computed deflection at the elevation of maximum moment

e_a = eccentricity due to anchor connection details (may be positive or negative, see discussion of design of wales, paragraph 6-3e).

(b) Shear. The required shear area of the section is calculated as described in paragraph 6-4c(1)(b).

(c) Combined Loading. When external effects other than an inclined anchor produce axial loading on the sheet piling, the minimum section modulus is given by

$$S_{\min} = [M_{\max} + T_{av}(y_m + e_a) + P(y_m - y_p + e_p)] / f_b \quad (6-11)$$

where

M_{\max} = maximum bending moment from the Free Earth method (unreduced)

T_{av} = axial component of the anchor force

y_m = computed deflection at the elevation of M_{\max}

e_a = eccentricity of the anchor force

P = additional axial load

y_p = deflection at the point of application of P

e_p = eccentricity of the point of application of P

It is recommended that $T_{av}(y_m + e_a) + P(y_m - y_p + e_p)$ be less than $M_{\max}/10$ unless it is demonstrated that buckling is unlikely.

(3) Anchored walls of concrete. Cross sections of prestressed or reinforced concrete walls shall be proportioned in accordance with the requirements specified in paragraphs 6-3.a(2) and (3).

e. Design of tie rods and wales. A majority of failures of anchored walls occur in the tie rods, wales, and anchors. Typical wale and tie rod configurations are shown in Figure 6-5. All connections in these components should be bolted and designed in accordance with the American Institute of Steel Construction (AISC) Specifications for Bolted Connections (Research Council on Structural Connections 1985). Because of the critical nature of the anchorage, the design of the tie rods and wales should be based on the anchor force calculated from the stability analysis with the factor of safety applied to the passive soil pressure as described in Chapter 5.

(1) Tie rod design. Tie rods are commonly steel rods with threaded connections including a turnbuckle

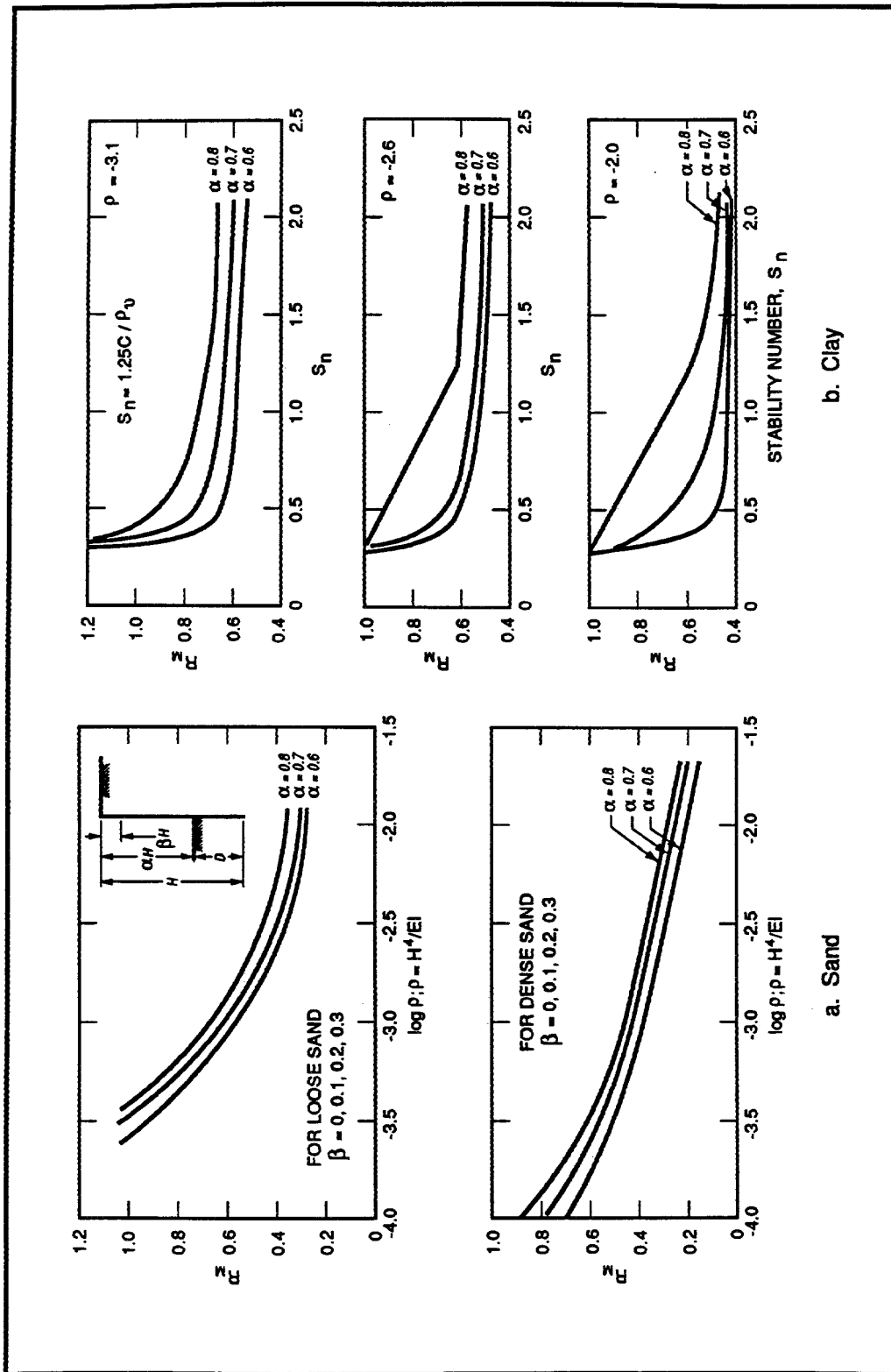

Figure 6-4. Rowe's moment-reduction coefficients (after Bowles 1982)

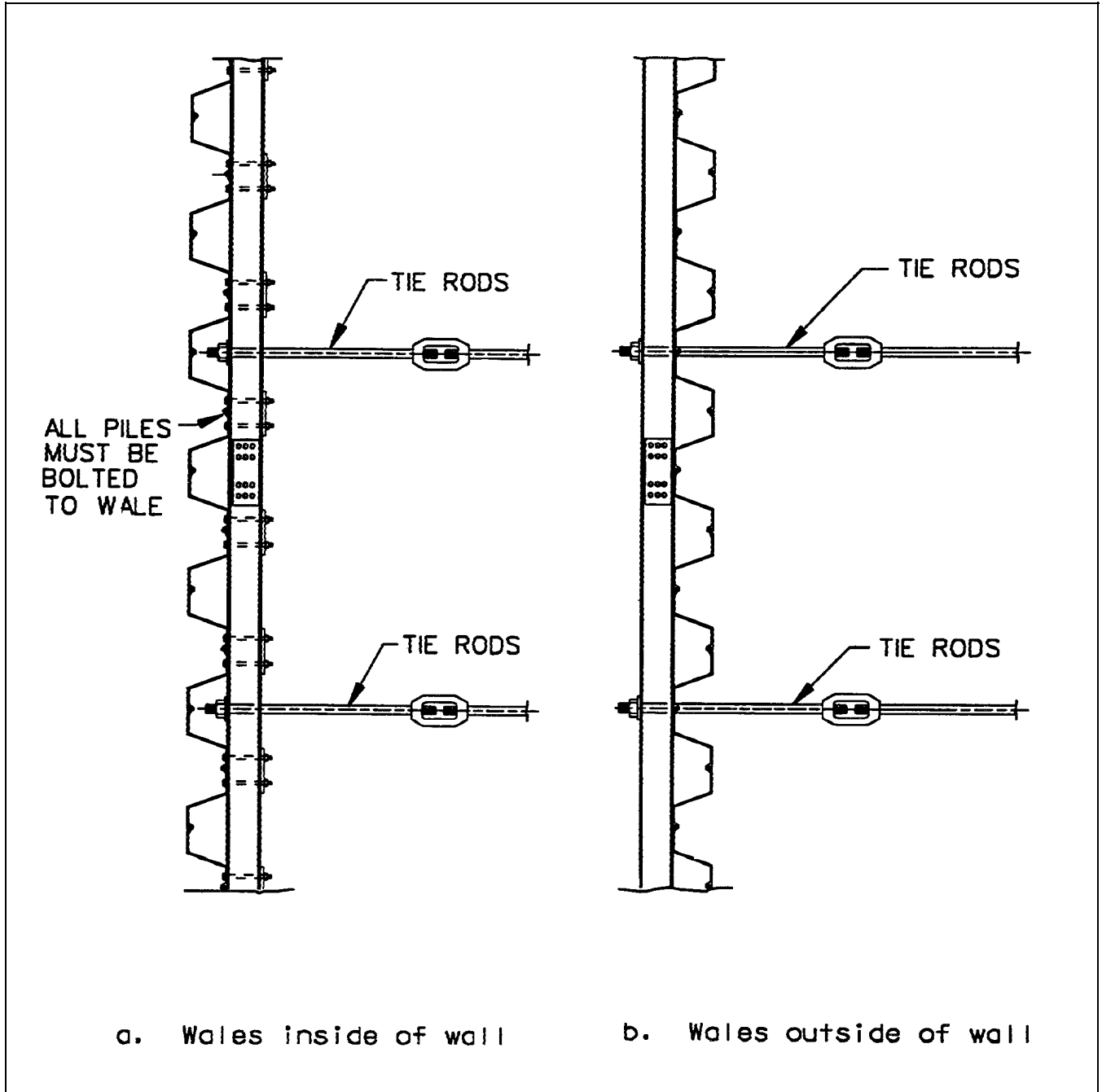

Figure 6-5. Typical wale configurations

for slack removal, Figure 6-5. Upset threads are recommended.

(a) Tie rod area. The force sustained by each tie rod is given by

$$T_{rod} = T_a S \quad (6-12)$$

where

T_a = anchor force per foot of wall from the stability analysis (see also Figure 6-3)

S = spacing between adjacent tie rods

The minimum required net area for a tie rod is

$$A_{net} = T_{rod} / f_t \quad (6-13)$$

where

A_{net} = available net tension area of the threaded rod

f_t = allowable tensile stress for the rod material according to

Steel rods: $f_t = 0.4 f_y$

Aluminum rods: f_t is the smaller of minimum yield strength divided by 2.5 or ultimate tension strength divided by 3.0.

(b) Tie rod yield strength. The tie rod yield strength is the product of A_{net} times f_y for steel rods and A_{net} times minimum yield strength for aluminum rods. The design capacity of the anchor wall or deadman, Chapter 5, should be sufficient to develop the tie rod yield strength.

(c) Tie rod support. The tie rod design is based on the assumption that the rod is straight and centrally loaded. The rod must be protected against any influence which tends to induce bending in the rod. Careful attention must be directed to the tie rod-to-wale connection and tie rod-to-anchor connection to eliminate any

eccentricities at these points. The tie rod must also be protected against any potential consolidation in the backfill. The geotechnical engineer should evaluate any potential settlement due to consolidation and the tie rod should be encased in a conduit of sufficient diameter to permit backfill consolidation without contact between the rod and conduit.

(2) Design of tendons for grouted anchors. Tendons for grouted anchors may be either rods or cables. Rods used as tendons should be designed according to the preceding strength requirements for tie rods. When cables are used, the size should be evaluated based on manufacturer's specifications for the sum of the anchor force (T_{rod} , Equation 6-12) and any alignment loads.

(3) Design of wales. Wales which transfer the tie rod forces to the sheet piling are usually composed of back-to-back channels as illustrated in Figures 6-5. From a load transfer standpoint, the most desirable position of the wales is on the outside of the piling, Figure 6-5a. When the wales are placed on the inside face, Figure 6-5b, each individual sheet pile must be bolted to the wale. The wale is assumed to act as a continuous flexural member over simple supports at the tie rod locations. The maximum bending moment in the wale may be approximated as

$$M_{max} = T_{ah} S^2 / 10 \quad (6-14)$$

where

T_{ah} = anchor force per foot of wall

S = distance between adjacent tie rods

Sizing of the wale cross section, wale-to-piling connections, and tie rod-to-wale connections shall be in accordance with the current *Manual of Steel Construction*, "Allowable Stress Design," as published by AISC (1989) with the exception that allowable stresses shall be limited to five-sixths of those specified in the design codes. The design should take into consideration such factors as web crippling and possible torsion, biaxial bending, and shear produced by inclined tie rods.

Chapter 7 Soil-Structure Interaction Analysis

7-1. Introduction

The classical design procedures discussed in Chapters 5 and 6 rely on several simplifying and often contradictory assumptions regarding the behavior of the wall/soil system. Some of the anomalies contained in the classical procedures are:

a. Incompatible pressures and displacements. In both cantilever and anchored wall design, the soil pressures are assumed to be either the limiting active or passive pressure at every point without regard to the magnitude or direction of wall/soil displacements. In the case of an anchored wall, the tendency of wall motion to produce a passive condition above the anchor is ignored. The effects of wall and anchor flexibilities on soil pressures are ignored, and the displacements are calculated based on hypothetical, and perhaps, unrealistic supports.

b. Effect of pile penetration. Analysis by the classical methods of a wall with a penetration greater than that required for stability indicates not only an increase in the factor of safety but attendant increases in soil pressures, bending moments, anchor forces, and deflections as well. While the increased deflections are consistent with the assumptions in the classical procedures, an increase in penetration should be expected to result in reduced deflections.

c. Multiple anchors. Approximate methods of design have been proposed for walls with multiple anchors, however these methods introduce further simplifying assumptions regarding system behavior and suffer from the same limitations as those for single anchored walls.

7-2. Soil-Structure Interaction Method

The soil-structure interaction (SSI) method of analysis described in this chapter enforces compatibility of deflections, soil pressures, and anchor forces while accounting for wall and anchor flexibilities. The SSI method is based on a one-dimensional (1-D) finite element model of the wall/soil system consisting of linearly elastic beam-column elements for the wall, distributed nonlinear Winkler springs to represent the soil and nonlinear concentrated springs to represent any anchors.

7-3. Preliminary Information

Required preliminary information for application of the SSI method includes the system characteristics described in paragraph 5-2*b* as well as the penetration of the sheet piling, sheet piling material and cross-sectional properties (area, moment of inertia, and modulus of elasticity), and anchor properties (tie rod area, modulus of elasticity, and flexible length). These data will be available for analysis of an existing wall/soil system. For use of the SSI method as a supplemental tool in design of a new system, an initial design using one of the classical methods may be performed and the SSI analysis used to refine the design.

7-4. SSI Model

The one-dimensional model of a typical 1-foot slice of the wall/soil system is shown in Figure 7-1. Nodes in the model are defined at the top and bottom of the wall, at soil layer boundaries on each side, at the groundwater elevation on each side, at the anchor elevations and at other intermediate locations to assure that the length of each beam element is no more than 6 inches. Lateral support is provided by the distributed soil springs and concentrated anchor springs. At present, there is no acceptable procedure to account for the effects of wall friction or adhesion in resisting vertical motions of the wall. The effects of these factors are included in the assessment of the lateral resistance of the soil. When an inclined anchor produces axial force in the piling, the bottom of the wall is assumed to be fixed against vertical translation. Conventional matrix structural analysis is used to relate the deformations of the system (defined by the horizontal and vertical translations and the rotations of the nodes) to the applied external forces. This results in a system of $3N$ (for a model with N nodes) nonlinear simultaneous equations which must be solved by iteration. The details of the analytical procedure are presented in the CWALSSI User's Guide (Dawkins 1992).

7-5. Nonlinear Soil Springs

The forces exerted by the distributed soil springs vary with lateral wall displacement between the active and passive limits as shown in Figure 7-2. Active and passive soil pressures are calculated for a factor of safety of 1 by the procedures described in Chapter 4 including wall/soil friction and adhesion. The at-rest pressure p_0 , corresponding to zero wall displacement, is obtained from

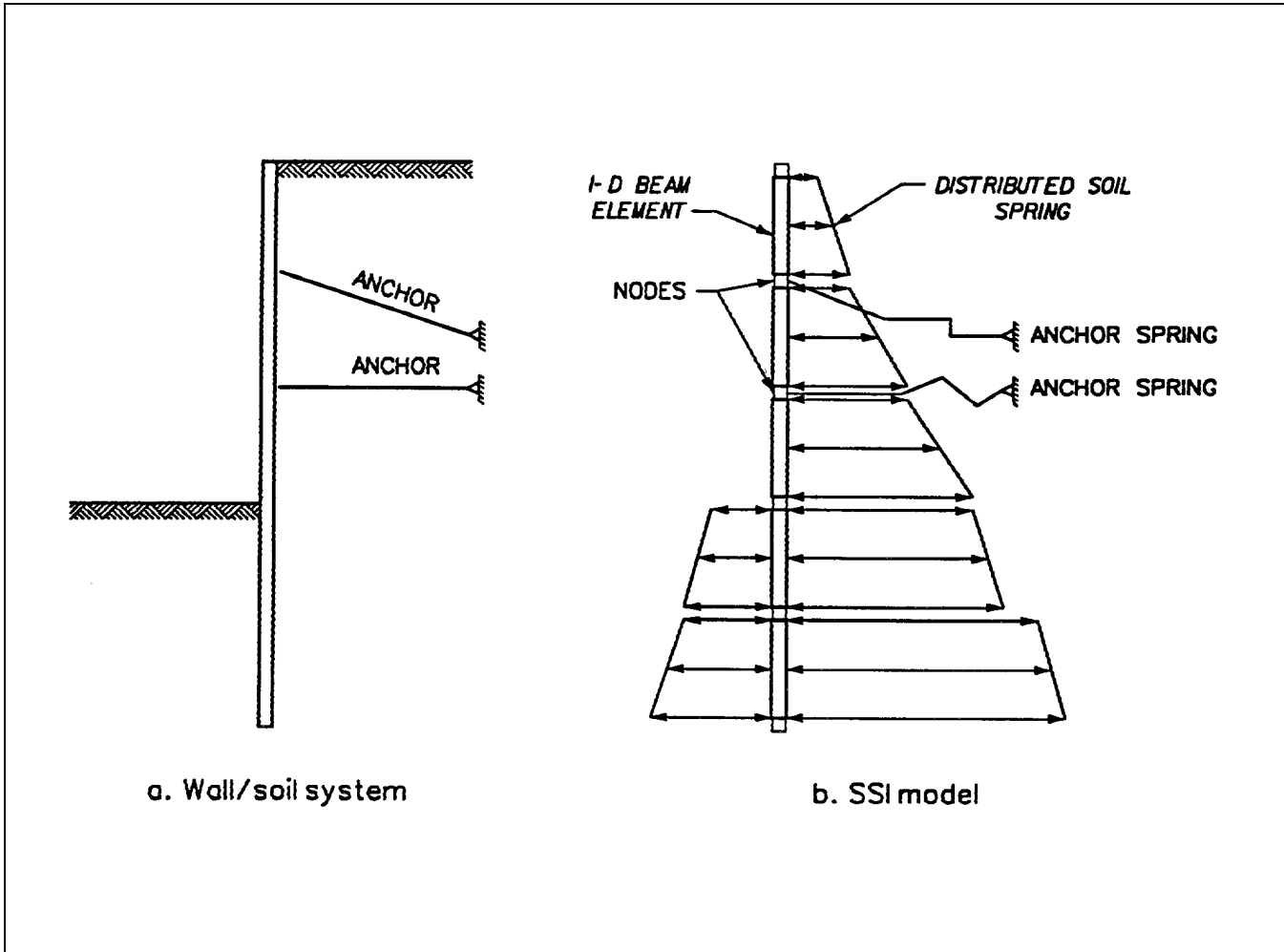

Figure 7-1. System for SSI analysis

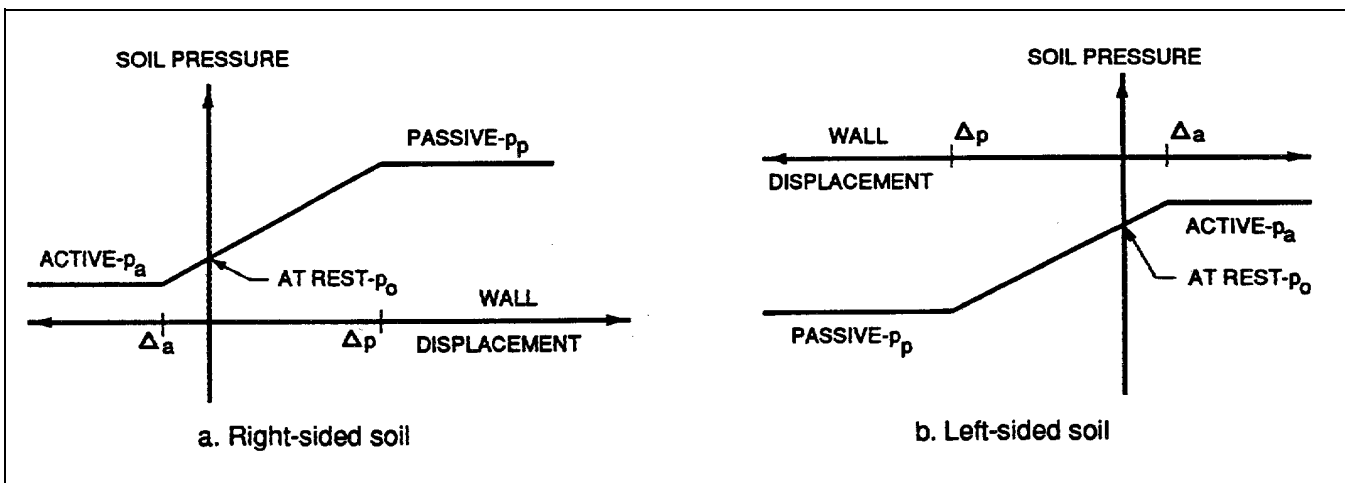

Figure 7-2. Distributed soil springs

$$P_o = p_v K_o \quad (7-1)$$

where

p_v = effective vertical soil pressure at the point of interest

K_o = at-rest soil coefficient

The at-rest coefficient should be ascertained by the geotechnical engineer during soil exploration. In the absence of test data, K_o may be estimated by

$$K_o = 1 - \sin(\phi) \quad (7-2)$$

Although the variation of soil pressure between limits follows a curved path, the simplified bilinear representation shown in Figure 7-2 is used. The displacements at which limiting active or passive pressure are reached depend on the type of soil and the flexibility of the wall. These influences are characterized by soil stiffness values and an estimate of the distance from the wall to which the soil is significantly stressed (the interaction distance). Rules-of-thumb for estimating the interaction distance are provided in the CWALSSI User's Guide (Dawkins 1992). Representative soil stiffnesses are given by Terzaghi (1955). With known values of soil stiffness, the transition displacements, p_a and p_p in Figure 7-2, for any node in the model are obtained for sand as

$$\Delta_a = \frac{P_o - P_a}{(s_a \cdot p_v)/(\gamma \cdot d)} \quad (7-3)$$

$$\Delta_p = \frac{P_p - P_o}{(s_p \cdot p_v)/(\gamma \cdot d)} \quad (7-4)$$

and for clay as

$$\Delta_a = \frac{P_o - P_a}{(s_a)/d} \quad (7-5)$$

$$\Delta_p = \frac{P_p - P_o}{(s_p)/d} \quad (7-6)$$

where

p_a , p_o , and p_p = active, at-rest, and passive pressures

s_a and s_p = active and passive soil stiffnesses, respectively

p_v = effective vertical soil pressure

γ = effective soil unit weight

d = interaction distance, all at the node of interest

7-6. Nonlinear Anchor Springs

Anchors are represented as concentrated nonlinear springs in which the force varies with wall displacement as shown in Figure 7-3. The limiting tension force is given by

$$F_t = A_r f_y \quad (7-7)$$

where

A_r = the effective area of the tie rod

f_y = yield stress of the material

The limiting force in compression F_c depends on the manner in which the tie rod is connected to the wales and the compressive axial load capacity of the tie rod (rod buckling) and may vary from zero to the yield value given in Equation 7-7. The displacements at which the linear variation of force ceases are given by

$$\Delta_t = \frac{F_t L}{E A_a} \quad (7-8)$$

$$\Delta_c = \frac{F_c L}{E A_a} \quad (7-9)$$

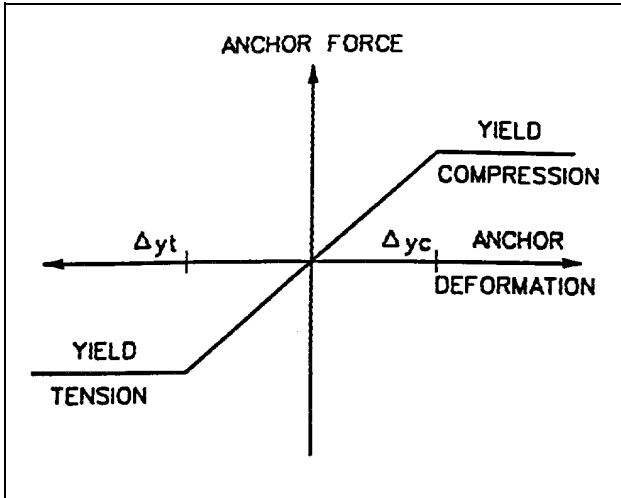

Figure 7-3. Anchor spring

where

L = length of tie rods attached to discrete anchors or the unbonded length of grouted anchors

E = modulus of elasticity of the rod

A_a = cross-sectional area of the rod

The force-deformation characteristic for cable tendons should be obtained from manufacturer's specifications.

7-7. Application of SSI Analysis

The SSI procedure provides solutions in which forces (bending moments, shears, anchor force, and soil pressures) are compatible with wall displacements at all points. In addition, solutions may be obtained by this method for stages intermediate to the final configuration as well as allowing for multiple anchors. However, it must be emphasized that the procedure is a "gravity turn-on" and does not take into account the cumulative effects of the construction sequence. The greatest uncertainty in the method is in selecting the soil stiffness parameters, consequently the method should be used to evaluate the sensitivity of the solution to variations in soil stiffness. Terzaghi (1955) has indicated that the forces in the system are relatively insensitive to large variations in soil stiffness, although calculated displacements are significantly affected. Although the forces and displacements are compatible in the solution, it must be recognized that the calculated deflections are only representative of the deformation of the wall and do not include displacements of the entire wall/soil mass.

Chapter 8 Engineering Considerations for Construction

8-1. General

This chapter addresses engineering considerations for sheet pile wall construction. Its intent is to give design and construction engineers an overview of installation and its effect on the design.

8-2. Site Conditions

Site conditions should be evaluated during the reconnaissance phase, with effort increasing as the design progresses. Overhead and underground obstructions, such as pipes, power lines, and existing structures, may dictate special construction techniques. Some situations may even necessitate a change in wall alignment. The effects of pile driving on nearby structures or embankments should also be considered.

8-3. Construction Sequence

a. Interim protection. Construction of a new flood-wall sometimes requires removal of the existing protection. In that situation it is necessary to provide interim protection or to construct the new wall in stages. Interim protection should be to the same level as the removed protection line. Staged construction should limit the breach to one that can be closed should floodwaters approach.

b. Relocations. Overhead utility lines are relocated temporarily for most sheet pile walls. Subsequent to pile driving, the lines can usually be placed back in their original position. Underground lines are removed for pile driving and then placed back through the sheet pile. Temporary bypass lines are necessary for some situations. Permanent relocation through the wall must allow for differential settlement between the wall and the utility lines.

8-4. Earthwork

a. Excavation. Excavation consists of the removal and disposal of material to the grades and dimensions provided on the plans. Excavation is generally required when capping or trenching sheet pile and for placement of tie rods or anchors. A dewatering system consisting of sumps and pumps or wells may be required depending on subsurface conditions. An excavation and

dewatering plan should be submitted by the contractor for review prior to commencement of work.

b. Voids due to driving. During pile driving operations, voids may form adjacent to the webs and flanges of the sheet piling due to soil drawdown. Typically, these voids are first pumped free of any water present, either due to seepage or rain, and then backfilled with a cement-bentonite-sand slurry. The slurry should be fluid enough to fill the voids and strong enough to approximate the strength of the insitu material.

c. Backfill. It is recommended that clean sands and gravels be used as backfill for retaining walls whenever possible. Material placed behind the wall should be compacted to prevent settlement. The amount of compaction required depends on the material used. Over compaction could induce additional lateral pressures that may not have been accounted for in the design. Typically, granular fill is placed in thin lifts, with each lift compacted before the next is placed. If backfill is to be placed on both sides of a wall, placement should be in simultaneous equal lifts on each side. There are some situations in which the use of clay backfill is unavoidable, as in backfill for walls in levees. Under these circumstances very strict controls on compaction are required.

8-5. Equipment and Accessories

a. General. The most common methods of installing sheet pile walls include driving, jetting, and trenching. The type of sheet piling often governs the method of installation. Contract specifications should prohibit the installation of sheet piling until the contractor's methods and equipment are approved.

b. Hammers. Types of driving hammers allowed for sheet piles include steam, air, or diesel drop, single-action, double-action, differential-action, or vibratory. The required driving energy range should be specified in foot-pounds based on the manufacturer's recommendations and the type of subsurface that will be encountered. Vibratory hammers are widely used because they usually can drive the piles faster, do not damage the top of the pile, and can easily be extracted when necessary. A vibratory hammer can drive piling up to eight times faster than impact hammers depending on the type of subgrade. When a hard driving condition is encountered, a vibratory hammer can cause the interlocks to melt. If the penetration rate is 1 foot or less per minute, the use of a vibratory hammer should be discontinued

and an impact hammer should be employed. The selection of the type or size of the hammer is based on the soil in which the pile is driven. The designer should be aware of the soil stiffness and possibility of obstructions which could cause failure or weakening of the sheet pile during driving.

c. Guides and Templates. To ensure that piles are placed and driven to the correct alignment, a guide structure or templates should be used. At least two templates should be used in driving each pile or pair of piles. Templates should also be used to obtain the proper plumbness of the sheet pile wall. Metal pilings properly placed and driven are interlocked throughout their length.

d. Accessories. A protective cap should be employed with impact hammers to prevent damage to the tops of the piling. Protective shoes to protect the tip are also available so that driving through harder soil strata is possible. If an obstruction is encountered during driving, it should be removed or penetrated with a chisel beam. During driving, the piling next to the one being driven may tend to follow below the final design elevation; in this case it may be necessary to pin in place piles together before the next pile is driven. Extraction, or pulling of specific piles for inspections, may be required if damage to the pile or interlocks is suspected or if excessive drift occurs. The circumstances should be carefully investigated to determine the cause of damage, and remedial action should be taken before re-driving.

8-6. Storage and Handling

a. Steel piling. Steel piling may be damaged when mishandled or stored improperly, resulting in permanently bent sheets. Piling stored on site should not exceed stack height and weight as shipped from the mill. Blocking is used to maintain piling in a level position. Blocking between bundles should be located directly over any blocking placed immediately below. Slings or other methods that prevent buckling during lifting are typically used on long lengths of steel piling. Sheets over 80 feet in length should be handled using a minimum of two pick-up points. Additional care is required when handling piling with protective coatings, and any damaged area will require repairs prior to driving.

b. Hot-rolled and cold-formed steel sections. The following are suggested blocking procedures for certain popular hot-rolled and cold-rolled steel sections:

(1) Blocking for PZ-40 and PZ-35 sheet pile sections should be spaced no more than 15 feet apart and no more than 2 feet from the ends.

(2) Blocking for PZ-21, PZ-22, PSA-23, PS-27.5, and PS-31 sheet pile sections should be spaced no more than 10 feet apart and no more than 2 feet from the ends.

(3) Blocking for SPZ-22, SPZ-23.5, SPZ-23, SPZ-26, FZ-7, and FZ-9 sheet pile sections should be spaced no more than 12 feet apart and no more than 2 feet from the ends.

Light-duty steel, aluminum, concrete, and plastic sheet piles are not commonly used for structural sheet pile walls and should be stored and handled according to the manufacturer's recommendations.

8-7. Methods of Installation

a. Driving. Sheet piling is typically driven with traditional pile driving equipment. The sheet piles are aligned using templates or a similar guiding structure instead of leads. For further information on pile driving equipment see EM 1110-2-2906.

b. Jetting. Pilings should not be driven with the aid of water jets without authorization of the design engineer. Jetting is usually authorized to penetrate strata of dense cohesionless soils. Authorized jetting should be performed on both sides of the piling simultaneously and must be discontinued during the last 5 to 10 feet of pile penetration. Adequate provisions must be made for the control, treatment, and disposal of runoff water.

c. Trenching. Under certain conditions it may be necessary to install a sheet pile wall by means of a trench. Trenching is usually done when the pile penetration is relatively shallow and there is a controlling factor which precludes driving. The backfill material on both sides of the trenched sheet pile wall should be carefully designed.

8-8. Driveability of Sheet Piling

a. Steel. Steel sheet piles are the most common and are usually placed by driving. The two types of steel sheet piles, hot-rolled and cold-rolled, have different driving considerations. Cold-rolled sections have a weaker interlock than the hot-rolled sections and in hard driving conditions this interlock might "unzip" or cause alignment problems which would require replacement of

the sheet piles. The cold-rolled sections also are usually thin and may be prone to overstressing during driving. The hot-rolled piles can be similarly damaged, but their interlocks are a ball- and socket-type connection which can "pop" if hard driving conditions are encountered.

b. Concrete. Concrete sheet piles usually cannot be driven with high-energy impact hammers without damaging the pile. They act as displacement piles and often require jetting to be driven. They are often trenched in place because they are usually used in low decorative walls which have a shallow depth of penetration.

c. Aluminum, timber, and plastics. These types of sheet piles are usually driven with light construction equipment, such as backhoes or jackhammers, to prevent damage to the piling. Walls composed of these materials are often trenched in place.

8-9. Tolerances

a. Driving. A vertical tolerance of plus or minus 1 1/2 inches, from the design elevation, is usually permitted. Sheet piling should not be driven more than 1/8 inch per foot out of plumb either in the plane of the wall or perpendicular to the plane of the wall.

b. Excavation. Generally, for an excavated surface on which concrete will be placed, the allowable vertical tolerance is 1/2 inch above line and grade and 2 inches below. For all other areas, vertical and horizontal tolerances of 6 inches, plus or minus, from the specified grade are usually permitted. Neither extremes of these tolerances should be continuous over an area greater than 200 square feet. Abrupt changes should not be permitted.

8-10. Anchors

Improperly planned construction methods may produce loads which exceed those used for design. Anchor forces, soil pressures, and water loads are affected by the method of construction and construction practices. The sequence of tightening tie rods should be specified to prevent overstresses in isolated sections of the wale or the sheet pile wall. Anchors and tie rods should be placed and tightened in a uniform manner so that no overstresses may occur. Backfilling above the anchor elevation should be carefully controlled to prevent bending of the tie rods. The backfill material should be controlled, and the thickness of compacted layers should be limited to ensure proper compaction and drainage of the backfill material.

Chapter 9 Special Design Considerations

9-1. I-Walls of Varying Thickness

Different restraint conditions are created with abrupt changes in wall geometry and by encasing steel sheet piles in concrete. Under thermal loads produced by heat of hydration and ambient temperature effects, stress related cracking can occur. The following actions were recommended by the Structures Laboratory, US Army Engineer Waterways Experiment Station (WES), after performing an investigation of cracking in I-wall monoliths in the New Tiger Island Floodwall. The investigation was limited to an I-wall with a lower portion thickness of 2 feet and an upper stem of 1 foot.

a. A 45-degree chamfer should be included at a change in geometry. See Figure 9-1 for details.

b. Generally, the top of the sheet piles should be placed 9 inches below the point at which the concrete section thickness is increased, except at each end of the monolith. Two sheet pile sections at each end of the monolith should be lowered an additional 9 inches, placing these sheets a total of 18 inches below the thickness change. The sheet piles located at the monolith joint should be notched down to 9 inches above the base of the wall. See Figures 9-1 and 9-2 for details.

c. Additional vertical and horizontal reinforcing steel should be placed at the ends of the monoliths to provide for temperature induced loads as shown in Figures 9-1 and 9-2.

9-2. Corrosion

a. General. The corrosion process in sheet piling is highly dependent on the environment in which it is placed. Generally, uncapped exposed sheet pile corrodes at varying rates averaging from 2 to 10 mils per year depending on the surrounding atmospheric conditions, i.e. rural versus heavy industrial. Corrosion rates usually decrease after the first few years of exposure. Sheet pile driven in natural undisturbed soil has a negligible corrosion rate due to the deficiency of oxygen at levels just below the groundline. Increased corrosion rates for piles in organic or fresh fills should be anticipated due to oxygen replenishment. In marine environments, the rate of corrosion is related to the type of water to which the sheet pile is exposed. Typically,

fresh water is the least corrosive and salt water the most, with contaminants and pollutants playing a major role in magnifying its corrosiveness. The critical zone for sheet piles exposed to water is the splash zone, the area between the still water elevation and the upper limit of wave action. This area corrodes at a much greater rate than if it remained completely submerged.

b. Methods of protection.

(1) The most common way of protecting steel sheet pile against corrosion is through the use of coatings. Generally, coal tar epoxy has become widely accepted for this application. If the piling is driven in fresh fill, the coating should cover the area in contact and extend a minimum of 2 additional feet. For sheet pile exposed to water, it is critical that the coating cover the splash zone and extend a minimum of 5 feet below the point where the sheeting remains submerged (EM 1110-2-3400).

(2) An additional means of providing corrosion resistance is by specifying ASTM A-690 (1989b) steel. This steel offers corrosion resistance superior to either A-328 (1989a) or A-572 (1988) through the addition of copper and nickel as alloy elements.

(3) Another effective method of protecting steel sheet pile is through the use of cathodic protection. The corrosion process is electrochemical in nature and occurs wherever there is a difference in electric potential on the piles surface. In an effort to provide electrical continuity, particularly in capped walls, a continuous No. 6 rebar should be provided atop the piling. The rebar should be welded at each section and terminate at monolith joints where a flexible jumper is required. If subsequent inspections show a rapid loss of material, the system can be externally charged to halt the flow of electric current, thus suppressing the corrosion process. See Figures 9-1 and 9-2 for details.

(4) In some cases a larger sheet pile section may be specified to provide for the anticipated loss of section resulting from corrosion.

9-3. Liquefaction Potential During Driving

The potential for liquefaction may exist at any time a dynamic operation takes place upon a granular foundation or a stratified foundation which contains granular soils. The risk of liquefaction should be evaluated on a case-by-case basis using the recommendations of Technical Report GL-88-9 (Torrey 1988). If the foundation

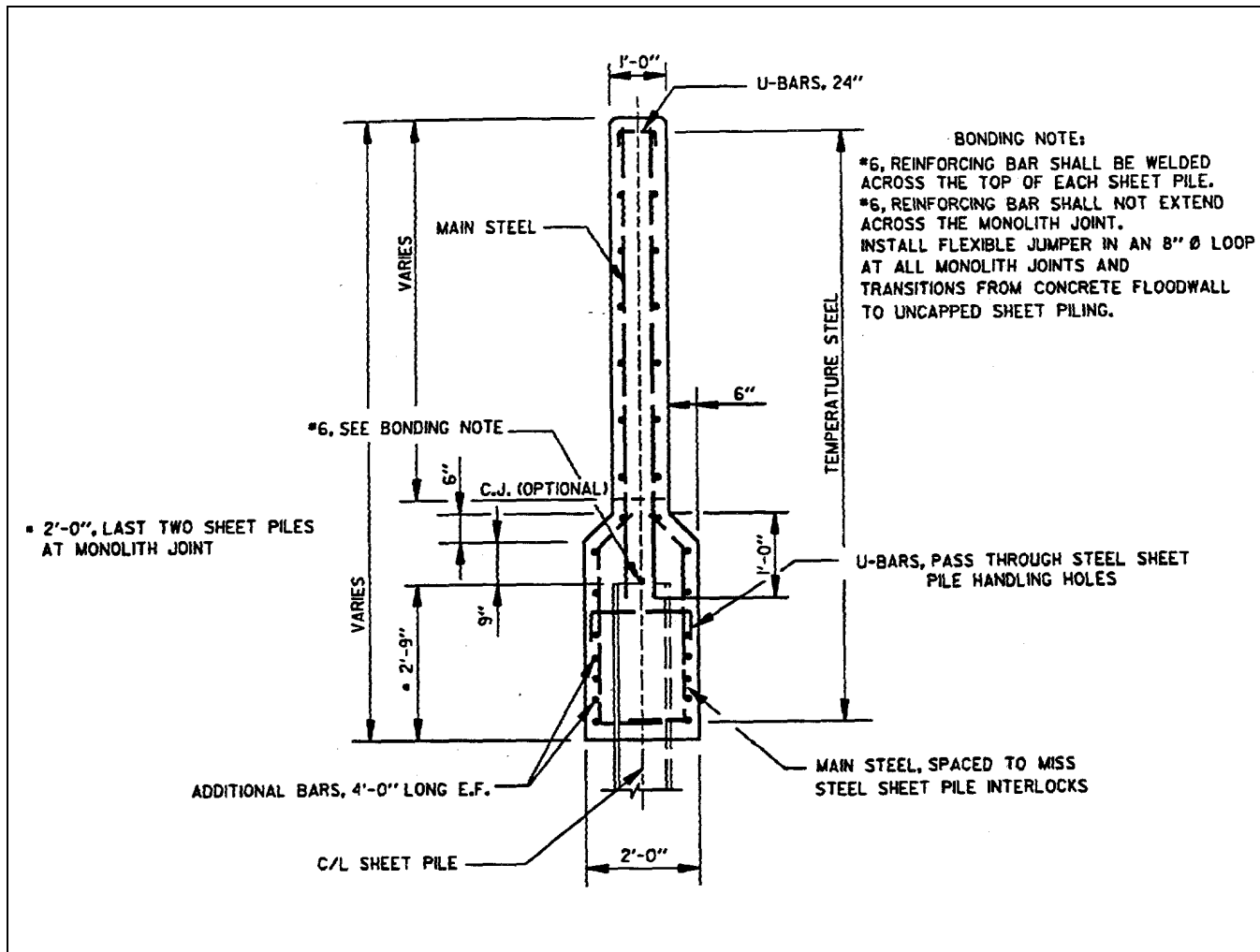

Figure 9-1. Typical section through I-wall of varying thickness

soils meet the criteria of this report, the assumption may be made that during pile driving the acceleration of soil particles will be sufficient to induce liquefaction, and therefore, a potential for damage exists. Limitations should then be set on pile driving, such as: maximum water stage during driving; minimum distance to the deposit of liquefaction prone soil; and size of pile driving hammer and its rated energy. A total ban on driving may be warranted. Limits on pile driving have been successfully applied along the levees of both the Mississippi and Atchafalaya Rivers. Pile driving is prevented or limited based upon the potential for liquefaction at a stage when the water level is above the landside ground surface and pile driving is planned within 1,500 feet of the levee or flood protection works. The extent of any limitations placed on pile driving should be evaluated against the potential for damage to the public.

9-4. Settlement

a. Effects on tie rods. Tie rods placed above loose granular or soft cohesive soils can be subjected to loads greater than that computed by conventional methods. As the underlying soils compress, either due to volume changes, distortion, or consolidation, the weight of the overlying soils induces additional loads as the rod deflects. Where excavation is necessary to place an anchor, the backfilled material should be a select soil, compacted to at least 90 percent of standard proctor maximum dry density. If soil conditions warrant the consideration of settlement, methods used in eliminating the effects include supporting the tie rod or encasing it in conduit.

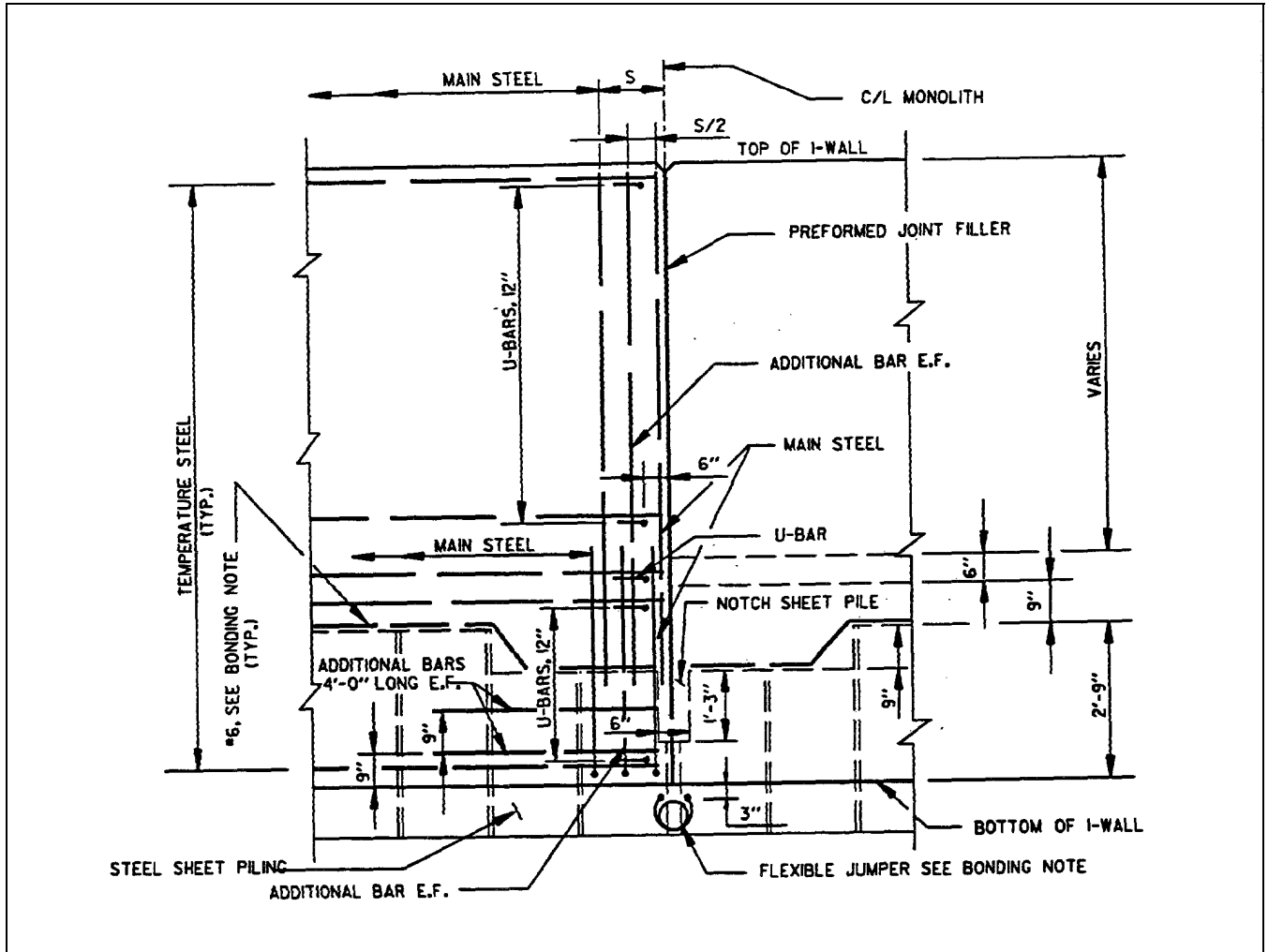

Figure 9-2. Detail of I-wall of varying thickness

b. *Effects on walls.* Wall settlement is a very serious concern in the overall system stability of the flood-wall, earth retaining wall, or tied backwall. In most cases the wall will settle along with the soil mass into which it is embedded. The consolidation method used for predicting wall settlement should be the one with which the designer is most familiar, whether it is the classic Terzaghi prediction or one of the hindcast-forecast methods. Since the wall cannot easily be modified in grade, the designer should consider the confidence level of the settlement prediction and overbuild the wall sufficiently to prevent settlement of the wall below grade. Concrete capping should be delayed until a major portion of the settlement has occurred. The "after settlement" configuration is used in the wall overturning analysis. Additionally, as the loads applied to the foundation by the wall are essentially horizontal the designer has to be cognizant of the fact that lateral

consolidation will occur with sustained loading. This should be evaluated and the wall system should be capable of compensating for this movement.

9-5. Transition Sections

a. *Sheet pile to levee.* When a sheet pile wall terminates within a levee, the piling is typically extended a minimum of 5 feet into the full levee section.

b. *I-wall to T-wall.* When a concrete capped I-Wall abuts a T-Wall, consideration must be given to the difference in deflections likely to occur. The relative movement may tear any embedded water stops. To accommodate these large movements between walls, a special sheet pile section with an L-Type waterstop is suggested. A typical detail is shown in Figure 9-3.

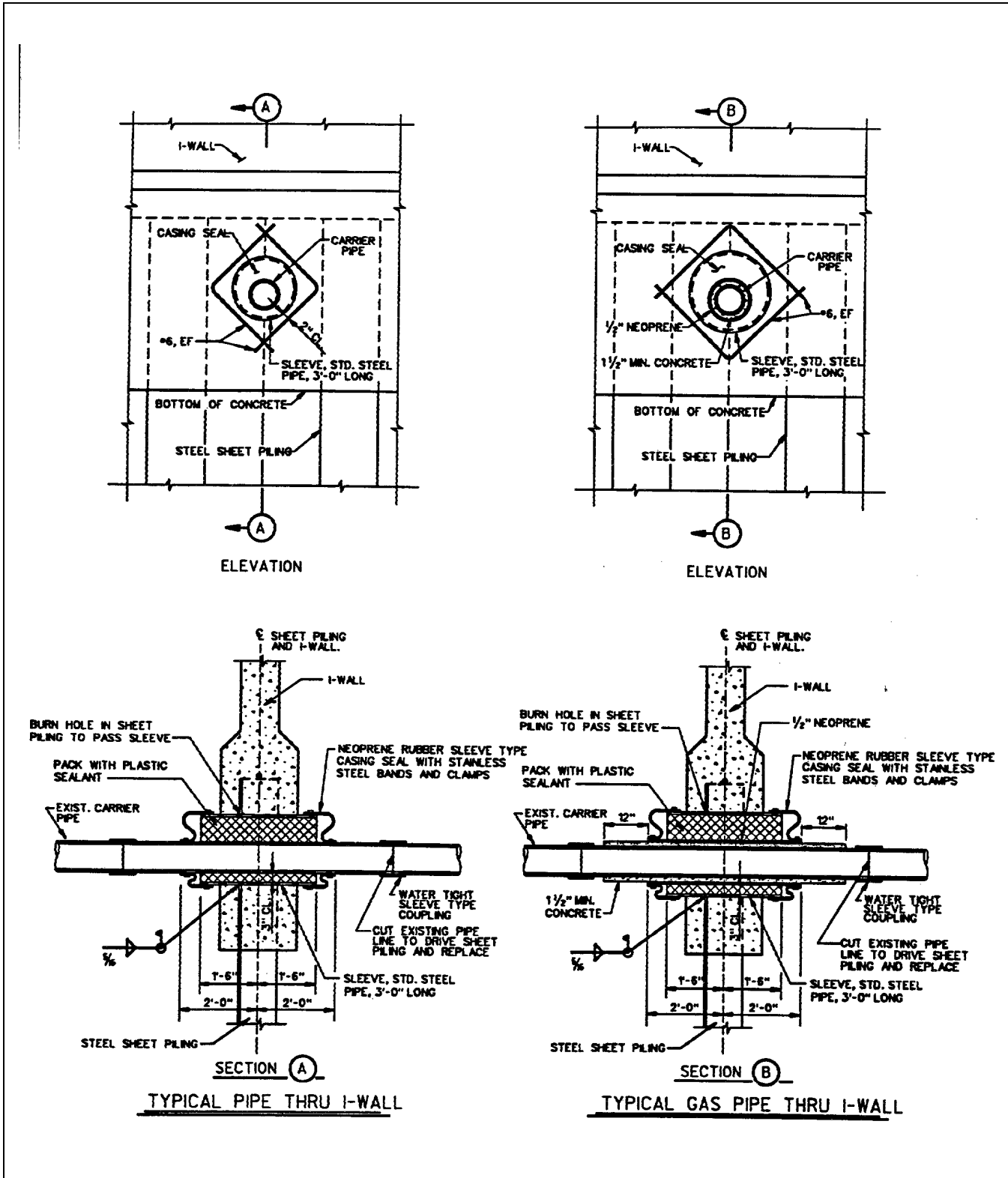

Figure 9-3. Typical utility crossings (Sheet 1 of 4)

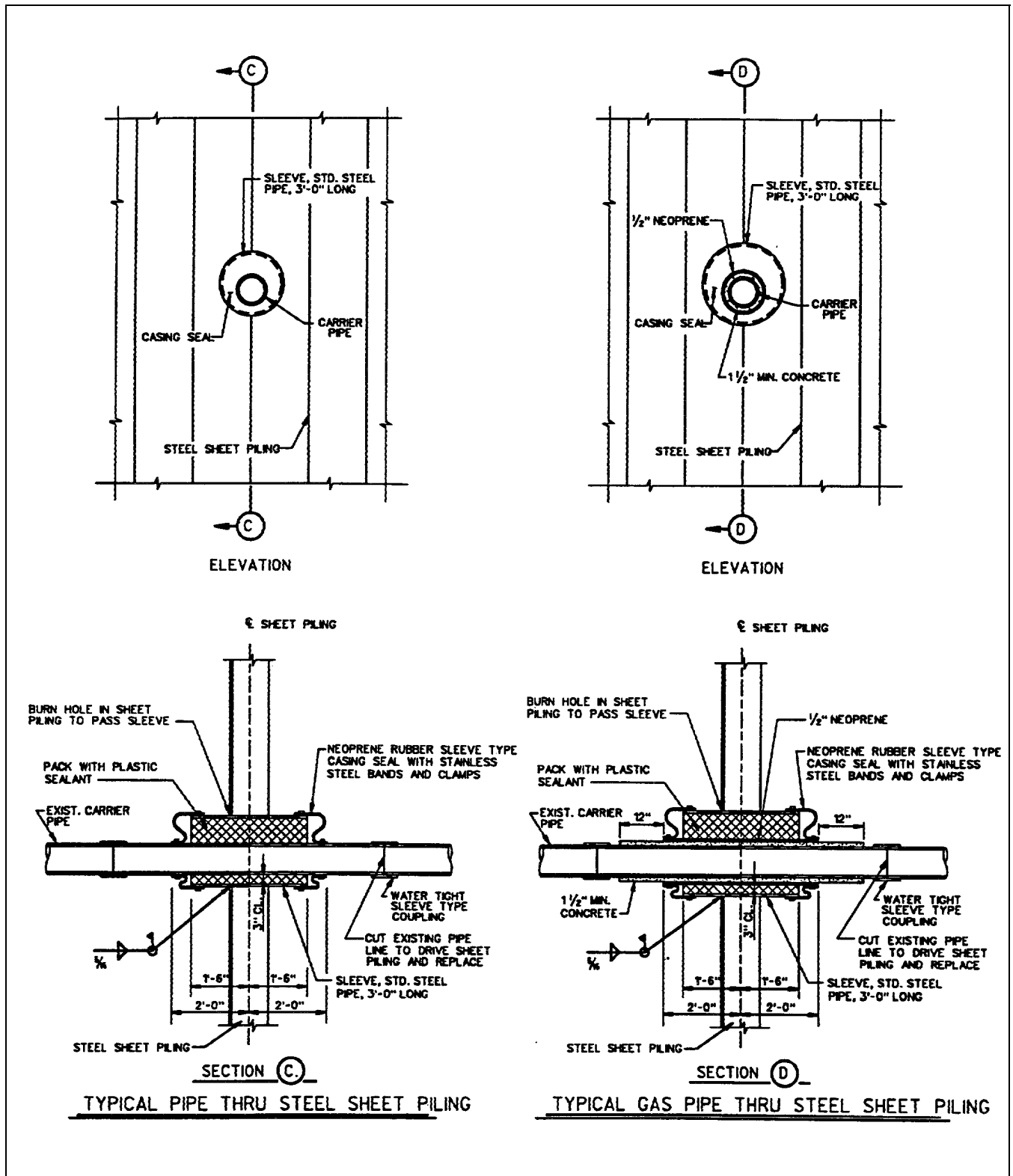

Figure 9-3. (Sheet 2 of 4)

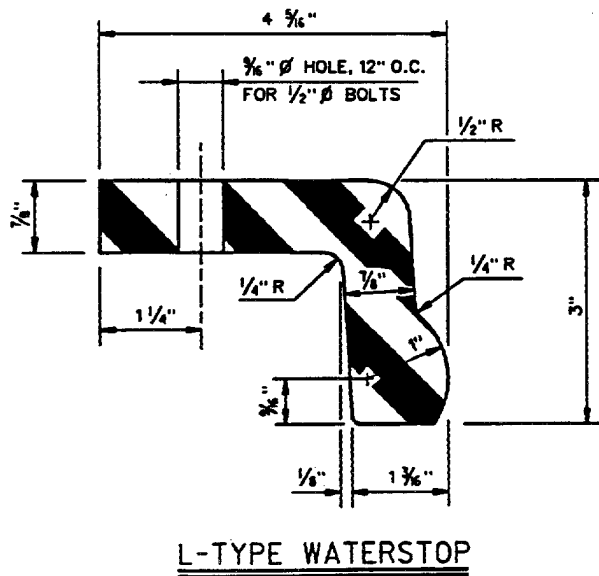
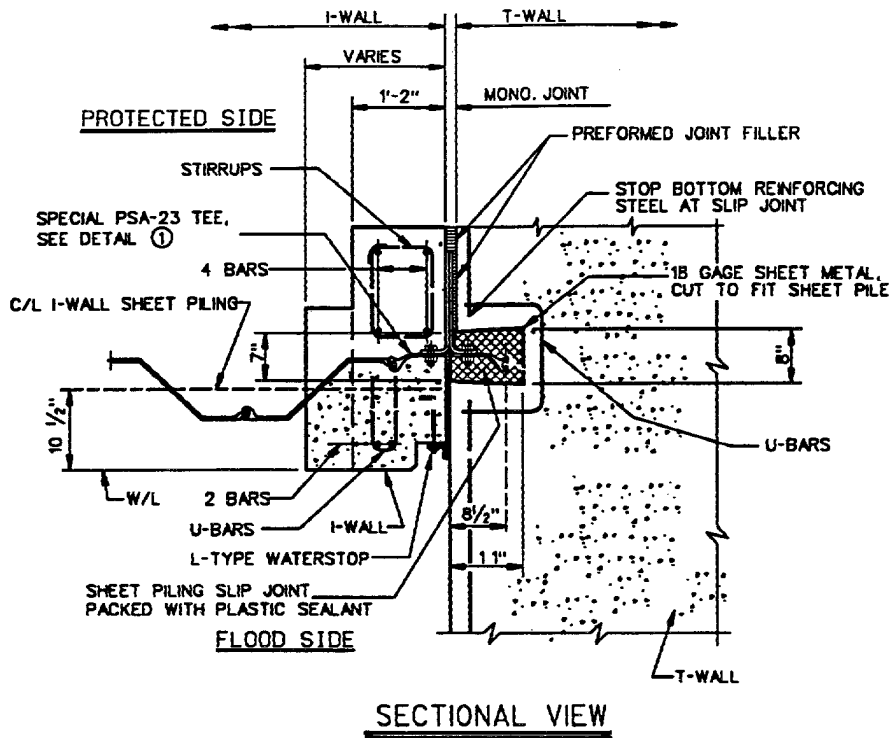

Figure 9-3. (Sheet 3 of 4)

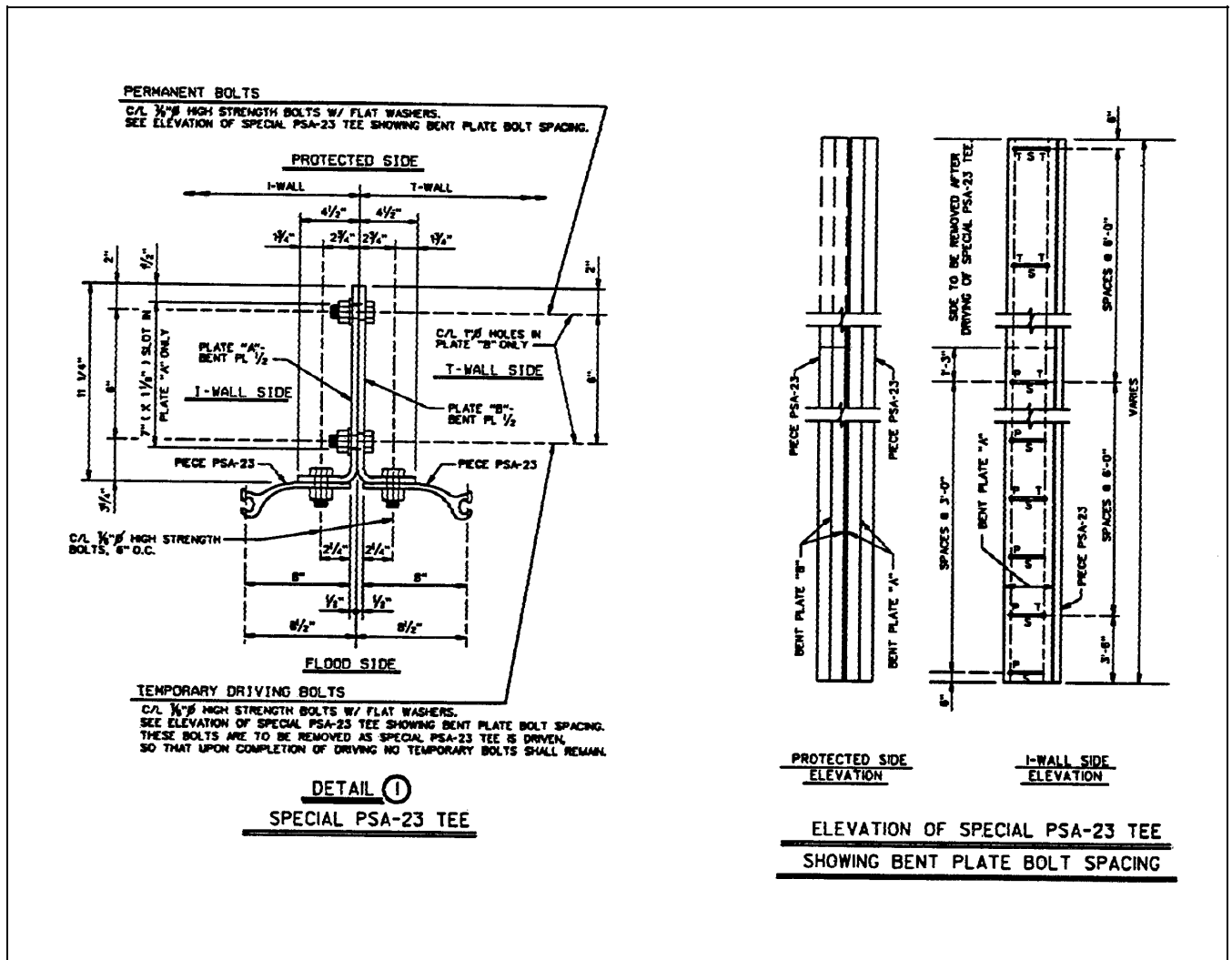

Figure 9-3. (Sheet 4 of 4)

9-6. Utility Crossings

When it is necessary for an underground utility to penetrate a sheet pile wall, a sleeve must be provided to permit relative motion at the crossing. Typically, the utility line is cut and reconnected on either side of the sleeve. The sleeve is then packed with a plastic sealant and covered with a water tight rubber boot. If conditions permit, an alternative method of passing a utility line through the sheet pile can be accomplished without cutting. This method consists of laterally displacing the utility line, driving the sheet piling, notching the sheet piling, and installing the sleeve in halves. See Figure 9-3 for typical utility crossing details.

9-7. Periodic Inspections

Structures should be inspected periodically to ensure structural integrity and to identify maintenance needs. Methods of inspection usually include visual inspection, magnetic particle inspection, ultrasonic inspection, radiography, and in some cases nondestructive testing. Typically sheet pile structures are visually inspected, relying heavily on the inspector's experience and knowledge. Ultrasonic measurements have been used to determine the remaining thickness of steel sheet piling. Information concerning frequency and manner of conducting periodic inspections is contained in ER 1110-2-100.

9-8. Maintenance and Rehabilitation

Timbers showing evidence of decay or steel piling significantly weakened by corrosion may require replacement. Concrete capping should be inspected for cracking and sealed as needed to prevent intrusion of foreign materials. Scour problems should be monitored and corrected if the stability of a vertical sheet pile wall is affected. Structures that have sustained major damage from storms or have deteriorated to a point at which normal maintenance is impractical may require total rehabilitation. At this time consideration should be given to alternative types of structures, such as replacing timber with steel.

9-9. Instrumentation

a. General. Instrumentation is usually required to monitor the performance of a sheet pile structure either during or after construction. Measurements of movements and pressures furnish valuable information for use in verifying design assumptions. Most importantly, the data may forewarn of a potentially dangerous situation

that could affect the stability of the structure. When a sheet pile wall is constructed on soft or diversely bedded soil, in areas of high or fluctuating water tables, or is frequently subjected to its maximum loading condition, instrumentation is certainly warranted.

b. Types of instruments. The kind of instruments selected should depend on site conditions, type of data required, reliability, durability, and ease of construction.

(1) Piezometers. A piezometer is an instrument mainly used for monitoring pore water pressures in foundation and backfill materials. The most common type is the open tube or open stand pipe piezometer, offering both simplicity and reliability. Pore pressure data can be used in an effective stress analysis, which can indicate a state of impending failure not apparent from a total stress (Q) analysis. Also from these piezometers a general foundation zone permeability can be estimated for use in seepage analyses. Piezometers attached to the sheet pile prior to installation should be protected from possible damage during driving. Installing piezometers, after driving or backfilling the sheet pile, becomes more difficult.

(2) Inclometers. Inclometers are generally used for measuring lateral displacement of foundations and embankments but can be used to monitor horizontal movements in sheet pile walls. The more common types employ a casing of either plastic, aluminum, or steel installed in a vertical bore hole or securely attached to the surface of a sheet pile. Normally, the lower end of the inclinometer casing is anchored firmly in rock to prevent movement at this end, thus serving as a reference point. If a rock anchor is not available, the lower end should penetrate a minimum of 15 feet in soil that will not experience movement. Inclometers attached to sheet piles are limited to the length of the pile if they are to survive driving. This limitation does not permit data collection for movements occurring below the tip. For these cases an additional inclinometer, which penetrates into a nonmoving deep formation, may be warranted.

(3) Strain gauges. The most common strain gauges used for monitoring sheet pile structures are of the electrical resistance and vibrating wire type. These gauges are designed to measure minute changes in a structural dimension, which can then be converted to a stress, load, or bending moment. The electrical resistance strain gauges are made so that they can be easily attached to a surface by means of an epoxy adhesive or by welding. The vibrating wire strain gauge is

usually arc or spot welded to the structural member. The success of these gauges depends highly on surface preparation, bonding, and waterproofing. Field tests have shown that these gauges, when properly installed and protected, will survive pile driving.

c. Data collection and presentation. Initial readings should be made on all instrumentation subsequent to installation, so that an initial data base is established. The person collecting the data should be experienced with the instrumentation devices in use. The frequency

of data collection should depend on an established monitoring schedule and should escalate during critical loading conditions or increased wall deflections. Profiles and alignments are typically collected on a yearly basis, while electronic devices should be read more frequently. Weather conditions and any apparent deformities at the site should be recorded. Data should be processed and evaluated by qualified personnel and reviewed by higher authority. Data should be displayed graphically so that various relations and trends can be readily seen.

Appendix A References

A-1. Required Publications

TM 3-357

Unified Soil Classification System

TM 5-849-1

Driving Equipment

EM 385-1-1

Safety and Health Requirements Manual

EM 1110-1-1804

Geotechnical Investigations

EM 1110-1-2009

Architectural Concrete

EM 1110-2-301

Guidelines for Landscape Planting at Flood Walls, Levees, and Embankment Dams

EM 1110-2-1612

Ice Engineering

EM 1110-2-1901

Seepage Analysis and Control for Dams

EM 1110-2-1902

Stability of Earth and Rock-Fill Dams

EM 1110-2-1906

Laboratory Soils Testing

EM 1110-2-1907

Soil Sampling

EM 1110-2-1913

Design and Construction of Levees

EM 1110-2-2102

Waterstops and Other Joint Materials

EM 1110-2-2104

Strength Design for Reinforced-Concrete Hydraulic Structures

EM 1110-2-2502

Retaining and Flood Walls

EM 1110-2-2906

Design of Pile Foundations

EM 1110-2-3400

Painting: New Construction and Maintenance

A-2. Related Publications

Section I

Corps of Engineers Publications

All related publications are available on interlibrary loan from the Research Library, US Army Engineer Waterways Experiment Station, ATTN: CEWES-IM-MI-R, 3909 Halls Ferry Road, Vicksburg, MS 39180-6199.

Dawkins 1982

Dawkins, William P. 1982 (Feb). "Soil Structure Interaction Analysis of Sheet Pile Retaining Walls (CSHTSSI)," U.S. Army Engineer Waterways Experiment Station, Vicksburg, MS.

Dawkins 1991

Dawkins, William P. 1991 (Oct). "Design/Analysis of Sheet Pile Walls by Classical Method - CWALSHT," Instruction Report ITL-91-1, U.S. Army Engineer Waterways Experiment Station, Vicksburg, MS.

Dawkins 1992

Dawkins, William P. 1992 (Aug). "User's Guide: Computer Program for Winkler Soil-Structure Interaction Analysis of Sheet Pile Walls (CWALSSI)," U.S. Army Engineer Waterways Experiment Station, Vicksburg, MS.

Ebeling and Morrison 1992

Ebeling, R. M., and Morrison, E. E. 1992 (Nov). "The Seismic Design of Waterfront Retaining Structures," Technical Report ITL-92-11, U.S. Army Engineer Waterways Experiment Station, Vicksburg, MS.

Manson 1978

Manson, Leonard H. 1978. "Cantilever Retaining Wall Design and Analysis - CANWAL," U.S. Army Engineer Waterways Experiment Station, Vicksburg, MS.

31 Mar 94

Mosher and Oner 1989

Mosher, Reed, and Oner, Mete. 1989 (Aug). "Theoretical Manual for Sheet Pile Walls," U.S. Army Engineer Waterways Experiment Station, Vicksburg, MS.

Torrey 1988

Torrey, III, Victor H. 1988 (Jun). "Retrospective Failures in Sand Deposits of the Mississippi River," Technical Report GL-88-9, U.S. Army Engineer Waterways Experiment Station, Vicksburg, MS.

U.S. Army Corps of Engineers 1988

U.S. Army Corps of Engineers. 1988 (Apr). "Periodic Inspection and Continuing Evaluation of Completed Civil Works Structures," ER 1110-2-100, Washington, DC.

U.S. Army Engineer Waterways Experiment Station 1980

U.S. Army Engineer Waterways Experiment Station. 1980 (Aug). *Rock Testing Handbook, Standard and Recommended Methods*. U.S. Army Engineer Waterways Experiment Station, Vicksburg, MS.

U.S. Army Engineer Waterways Experiment Station 1984

U.S. Army Engineer Waterways Experiment Station. 1984. "Shore Protection Manual," Coastal Engineering Research Center, U.S. Army Engineer Waterways Experiment Station, Vicksburg, MS.

U.S. Army Engineer Waterways Experiment Station 1990

U.S. Army Engineer Waterways Experiment Station. 1990 (Feb). "User's Guide: Computer Program for Design and Analysis of Sheet Pile Walls by Classical Methods (CWALSHT)," Instruction Report ITL-90-1, U.S. Army Engineer Waterways Experiment Station, Vicksburg, MS.

Whitman and Liao 1985

Whitman, R. V., and Liao, S. 1985 (Jan). "Seismic Design of Gravity Retaining Walls," Miscellaneous Paper GL-85-1, U.S. Army Engineer Waterways Experiment Station, Vicksburg, MS.

Section II

Other Publications

All related publications are available on interlibrary loan from the Research Library, U.S. Army Engineer Waterways Experiment Station, ATTN: CEWES-IM-MI-R, 3909 Halls Ferry Road, Vicksburg, MS.

Allen, Duncan, and Snacio 1988

Allen, R. L., Duncan, J. M., and Snacio, R. T. 1988. "An Engineering Manual For Sheet Pile Walls," Department of Civil Engineering, Virginia Tech, Blacksburg, VA.

The Aluminum Association 1976

The Aluminum Association. 1976 (Apr). "Specifications for Aluminum Structures," New York, NY.

American Concrete Institute 1983

American Concrete Institute. 1983. "Building Code Requirements for Reinforced Concrete," ACI 318-83, Detroit, MI.

American Institute of Steel Construction 1989

American Institute of Steel Construction. 1989. *Manual of Steel Construction*, "Allowable Stress Design," 9th ed., New York, NY.

American National Standards Institute 1982

American National Standards Institute. 1982. "Minimum Design Loads for Buildings and Other Structures," A 58.1, American National Standards Institute, New York, NY.

American Society for Testing and Materials 1981

American Society for Testing and Materials. 1981. "Method for Water Absorption of Plastics," D 570-81, *1988 Annual Book of ASTM Standards*, Vol 08.01, Philadelphia, PA.

American Society for Testing and Materials 1984

American Society for Testing and Materials. 1984. "Method for Penetration Test and Split-Barrel Sampling of Soils," D 1586-84, *1988 Annual Book of ASTM Standards*, Vol 04.08, Philadelphia, PA.

American Society for Testing and Materials 1986a

American Society for Testing and Materials. 1986a. "Method for Deep, Quasi-Static, Cone and Friction-Cone Penetration Tests of Soil," D 3441-79-86, *1988 Annual Book of ASTM Standards*, Vol 04.08, Philadelphia, PA.

American Society for Testing and Materials 1986b

American Society for Testing and Materials. 1986b. "Method for Flexural Properties of Unreinforced and Reinforced Plastics and Electrical Insulating Materials," D 790-86, *1988 Annual Book of ASTM Standards*, Vol 08.01, Philadelphia, PA.

American Society for Testing and Materials 1987

American Society for Testing and Materials. 1987. "Method for Indentation Hardness of Rigid Plastic by Means of a Barcol Impressor," D 2583-87, *1988 Annual Book of ASTM Standards*, Vol 08.02, Philadelphia, PA.

American Society for Testing and Materials 1988

American Society for Testing and Materials. 1988. "Specifications for High-Strength Low-Allow Columbium-Vanadium Steels of Structural Quality," A 572-89, *1988 Annual Book of ASTM Standards*, Vol 01.04, Philadelphia, PA.

American Society for Testing and Materials 1989a

American Society for Testing and Materials. 1989a. "Specifications for Steel Sheet Piling," A 328-89, *1988 Annual Book of ASTM Standards*, Vol 01.04, Philadelphia, PA.

American Society for Testing and Materials 1989b

American Society for Testing and Materials. 1989b. "Specifications for High-Strength Low-Alloy Steel H-Piles and Sheet Piling for Use in Marine Environments," A 690-89, *1988 Annual Book of ASTM Standards*, Vol 01.04, Philadelphia, PA.

American Society for Testing and Materials 1989c

American Society for Testing and Materials. 1989c. "Specifications for Steel Sheet Piling, Cold-Formed, Light Gage," A 857-89, *1988 Annual Book of ASTM Standards*, Vol 01.04, Philadelphia, PA.

American Society for Testing and Materials 1989d

American Society for Testing and Materials. 1989d. "Method for Tensile Properties of Plastics," D 638-89, *1988 Annual Book of ASTM Standards*, Vol 08.01, Philadelphia, PA.

American Society for Testing and Materials 1990

American Society for Testing and Materials. 1990. "Test Methods for Compressive Properties of Rigid Plastic," D 695-90, *1990 Annual Book of ASTM Standards*, Vol ____ , Philadelphia, PA.

Baguelin, Jezequel, and Shields 1978

Baguelin, F., Jezequel, J. F., and Shields, J. F. 1978. *The Pressuremeter and Foundation Engineering*, Trans-Tech Publications, Rockport, MA.

Bjerrum and Simons 1960

Bjerrum, L., and Simons, N. E. 1960. "Comparison of Shear Strength Characteristics of Normally Consolidated Clays," *Proceedings of the ASCE Research Conference*

on the Shear Strength of Cohesive Soils, Boulder, CO pp 711-726.

Bowles 1982

Bowles, J. E. 1982. *Foundation Analysis and Design*, 3rd ed., McGraw-Hill, New York, NY.

Clough and Duncan 1971

Clough, G. W., and Duncan, J. M. 1971. "Finite Element Analyses of Retaining Wall Behavior," *Journal of the Soil Mechanics and Foundations Division*, American Society of Civil Engineers, Vol 97, No. SM12, Proceedings Paper No. 8583, pp 1657-1673.

Das 1984

Das, B. M. 1984. *Principles of Foundation Engineering*, Brooks/Cole Engineering Division, Monterey, CA.

Gardner 1977

Gardner, W. S. 1977. "Soil Property Characterization in Geotechnical Engineering Practice," *Geotechnical/Environmental Bulletin*, Vol X, No. 2, Woodward Clyde Consultants, San Francisco, CA.

Kenney 1959

Kenney, T. C. 1959. Discussion of "Geotechnical Properties of Glacial Lake Clays," by T. H. Wu, *Journal of the Soil Mechanics and Foundations Division*, American Society of Civil Engineers, Vol 85, No. SM3, pp 67-79.

Ladd, Foote, Ishihara, Schlosser, and Poulos 1977

Ladd, C. C., Foote, R., Ishihara, K., Schlosser, F., and Poulos, H. G. 1977. "Stress-Deformation and Strength Characteristics," State-of-the-Art Report, *Proceedings of the Ninth International Conference on Soil Mechanics and Foundation Engineering*, Tokyo, Vol 2, pp 421-494.

Lambe and Whitman 1969

Lambe, T. W., and Whitman, R. V. 1969. *Soil Mechanics*, Wiley, New York, NY, pp 553.

Marcuson and Bieganousky 1977

Marcuson, W. F., and Bieganousky, W. A. 1977 (Nov). "SPT and Relative Density in Coarse Sands," *Journal of the Geotechnical Engineering Division*, American Society of Civil Engineers, Vol 103, No. GT11, pp 1295-1309.

Meyerhof 1956

Meyerhof, G. G. 1956. "Penetration Tests and Bearing Capacity of Cohesionless Soils," *Journal of the Soil*

Mechanics and Foundations Divisions, American Society of Civil Engineers, Vol 82, No. SM1, pp 1-19.

National Forest Products Association 1986

National Forest Products Association. 1986. "National Design Specifications for Wood Construction," Washington, DC.

Newmark 1942

Newmark, N. M. 1942. "Influence Charts for Computation of Stresses in Elastic Foundations," *University of Illinois Engineering Experiment Station Bulletin*, Series No. 338, Vol 61, No. 92, Urbana, IL, reprinted 1964, pp 28.

Peck and Bazaraa 1969

Peck, R. B., and Bazaraa, A. S. 1969. "Discussion on Settlement of Spread Footings on Sand," *Journal of the Soil Mechanics and Foundations Division*, American Society of Civil Engineers, Vol 95, No. SM3, pp 905-909.

Peck, Hanson, and Thornburn 1974

Peck, R. B., Hanson, W. E., and Thornburn, T. H. 1974. *Foundation Engineering*, Wiley, NY.

Potyondy 1961

Potyondy, J. G. 1961. "Skin Friction Between Various Soil and Construction Materials," *Geotechnique*, Vol XI, No. 4, pp 339-353.

Research Council on Structural Connections 1985

Research Council on Structural Connections. 1985. "Specification for Structural Using ASTM A325 and A490 Bolts," American Institute of Steel Construction, Inc., Chicago, IL.

Robertson and Campanella 1983

Robertson, P. K., and Campanella, R. G. 1983. "Interpretation of Cone Penetration Tests; Parts I and II," *Canadian Geotechnical Journal*, Vol 20, No. 4, pp 718-745.

Rowe 1952

Rowe, P. W. 1952. "Anchored Sheet-Pile Walls," *Proceedings, Institution of Civil Engineers*, London, Part I, Vol 1, No. 5788, January, pp 27-70.

Rowe 1955

Rowe, P. W. 1955a. "A Theoretical and Experimental Analysis of Sheet-Pile Walls," *Proceedings, Institution*

of Civil Engineers, London, Part I, Vol 4, No. 5989, January, pp 32-69.

Rowe 1955

Rowe, P. W. 1955b. "Sheet-Pile Walls Encastre at the Anchorage," *Proceedings, Institution of Civil Engineers*, London, Part I, Vol 4, No. 5990, January, pp 70-87.

Rowe 1956

Rowe, P. W. 1956. "Sheet-Pile Walls at Failure," *Proceedings, Institution of Civil Engineers*, London, Part I, Vol 5, No. 6107, May, pp 276-315.

Rowe 1957a

Rowe, P. W. 1957a. "Sheet-Pile Walls in Clay," *Proceedings, Institution of Civil Engineers*, London, Vol 7, No. 6201, July, pp 629-654.

Rowe 1957b

Rowe, P. W. 1957b. "Sheet-Pile Walls Subject to Line Resistance Above the Anchorage," *Proceedings, Institution of Civil Engineers*, London, Vol 6, No. 6233, June, pp 629-654.

Schmertmann 1975

Schmertmann, J. H. 1975. "Measurement of In-Situ Strength," *Proceedings of the Conference on In-Situ Measurement of Soil Properties*, American Society of Civil Engineers, pp 55-138.

Seed, Arango, and Chan 1975

Seed, H. B., Arango, I., and Chan, C. K. 1975. "Evaluation of Soil Liquefaction Potential During Earthquakes," *Report No. EERC 75-28*, Earthquake Engineering Research Center, College of Engineering, University of California, Berkeley, CA.

Teng 1962

Teng, W. C. 1962. *Foundation Design*, Prentice Hall, Englewood Cliffs, NJ.

Terzaghi 1934

Terzaghi, K. 1934. "Large Retaining Wall Tests," *Engineering News - Record*, Vol 85, February 1 - April 19.

Terzaghi 1943

Terzaghi, K. 1943. *Theoretical Soil Mechanics*, Wiley, NY.

Terzaghi 1954

Terzaghi, K. 1954. "Anchored Bulkheads," *Transactions*, American Society of Civil Engineers, Vol 119.

Terzaghi 1955

Terzaghi, K. 1955. "Evaluation of Coefficients of Subgrade Reaction," *Geotechnique*, Vol 5, pp 297-326.

U.S. Department of the Navy 1971

U.S. Department of the Navy. 1971. "Soil Mechanics, Foundations, and Earth Structures," NAVFAC Design Manual DM-7, Washington, DC.

U.S. Department of the Navy 1982

U.S. Department of the Navy. 1982 (May). "Foundations and Earth Structures," NAVFAC DM-7.2, Naval Facilities Engineering Command, Alexandria, VA.

U.S. Department of the Navy 1987

U.S. Department of the Navy. 1987 (Oct). "Piers and Wharfs," Military Handbook-1025/1, Naval Facilities Engineering Command, Alexandria, VA.