



Geometric Design of Roundabouts

Course Number: CE-02-112

PDH: 5

Approved for: AK, AL, AR, FL, GA, IA, IL, IN, KS, KY, LA, MD, ME, MI, MN, MO, MS, MT, NC, ND, NE, NH, NJ, NM, NV, NY, OH, OK, OR, PA, SC, SD, TN, TX, UT, VA, VT, WI, WV, and WY

New Jersey Professional Competency Approval #24GP00025600

North Carolina Approved Sponsor #S-0695

Maryland Approved Provider of Continuing Professional Competency

Indiana Continuing Education Provider #CE21800088

Florida Provider #0009553 License #868

NYSED Sponsor #274

This document is the course text. You may review this material at your leisure before or after you purchase the course. In order to obtain credit for this course, complete the following steps:

1) Log in to My Account and purchase the course. If you don't have an account, go to New User to create an account.

2) After the course has been purchased, review the technical material and then complete the quiz at your convenience.

3) A Certificate of Completion is available once you pass the exam (70% or greater). If a passing grade is not obtained, you may take the quiz as many times as necessary until a passing grade is obtained (up to one year from the purchase date).

If you have any questions or technical difficulties, please call (508) 298-4787 or email us at admin@PDH-Pro.com.



NCHRP

REPORT 672

Roundabouts: An Informational Guide

Second Edition

TRANSPORTATION RESEARCH BOARD
OF THE NATIONAL ACADEMIES

NATIONAL
COOPERATIVE
HIGHWAY
RESEARCH
PROGRAM

In Cooperation with



U.S. Department
of Transportation

Federal Highway
Administration

NCHRP REPORT 672

**Roundabouts:
An Informational Guide**

Second Edition

**Lee Rodegerdts, Justin Bansen, Christopher Tiesler,
Julia Knudsen, and Edward Myers**
KITTELSON & ASSOCIATES, INC.
Portland, OR

Mark Johnson
MTJ ENGINEERING, INC.
Madison, WI

Michael Moule
LIVABLE STREETS INC.
Tampa, FL

Bhagwant Persaud and Craig Lyon
PERSAUD AND LYON
Toronto, ON, Canada

Shauna Hallmark and Hillary Isebrands
CENTER FOR TRANSPORTATION RESEARCH AND EDUCATION
IOWA STATE UNIVERSITY
Ames, IA

R. Barry Crown
RODEL SOFTWARE LTD
United Kingdom

Bernard Guichet
CETE L'OUEST
France

Andrew O'Brien
O'BRIEN TRAFFIC
Australia

Subscriber Categories
Highways • Design

Research sponsored by the American Association of State Highway and Transportation Officials
in cooperation with the Federal Highway Administration

TRANSPORTATION RESEARCH BOARD

WASHINGTON, D.C.
2010
www.TRB.org

6.1 INTRODUCTION

Roundabout design involves trade-offs between safety, operations, and accommodation of the design vehicle.

Some roundabout features are uniform, while others vary depending on the location and size of the roundabout.

The contents of this chapter are intended to serve as guidance, not as a standard or rule.

The use of a design technique not explicitly included in this chapter or a value that falls outside of the ranges presented in this chapter does not automatically create a fatal flaw or unsafe condition provided that the design principles can be achieved.

Roundabout design is an iterative process.

The geometric design of a roundabout requires the balancing of competing design objectives. Roundabouts operate most safely when their geometry forces traffic to enter and circulate at slow speeds. Poor roundabout geometry has been found to negatively impact roundabout operations by affecting driver lane choice and behavior through the roundabout. Many of the geometric parameters are governed by the maneuvering requirements of the design vehicle. Thus, designing a roundabout is a process of determining the optimal balance between safety provisions, operational performance, and accommodation of the design vehicle.

While the basic form and features of roundabouts are usually independent of their location, many of the design outcomes depend on the surrounding speed environment, desired capacity, available space, required numbers and arrangements of lanes, design vehicle, and other geometric attributes unique to each individual site. In rural environments where approach speeds are high and bicycle and pedestrian use may be minimal, the design objectives are significantly different from roundabouts in urban environments where bicycle and pedestrian safety are a primary concern. Additionally, many of the design techniques are substantially different for single-lane roundabouts than for roundabouts with two or more lanes.

The contents of this chapter are intended to serve as guidance and should not be interpreted as a standard or rule. As described in this chapter, roundabout design is an iterative process where a variety of design objectives must be considered and balanced within site-specific constraints. Maximizing the operational performance and safety for a roundabout requires the engineer to think through the design rather than rely upon a design template. Throughout this chapter, ranges of typical values are given for many of the different geometric elements to provide guidance in the design of individual roundabout components. The use of a design technique not explicitly included in this chapter or a value that falls outside of the ranges presented does not automatically create a fatal flaw or unsafe condition provided that the design principles presented in Section 6.2 can be achieved.

Exhibit 6-1 provides a general outline for the design process, incorporating elements of project planning, preliminary design, and final design into an iterative process. Information from the operational analysis is used to determine the required number of lanes for the roundabout (single or multilane), which dictates the required size and many other design details. The basic design should be laid out based upon the principles identified in Section 6.2 to a level that allows the engineer to verify that the layout will meet the design objectives. The key is to conduct enough work to be able to check the design and identify whether adjustments are necessary. Once enough iteration has been performed to identify an optimum size, location, and set of approach alignments, additional detail can be added to the design based upon more specific information provided in Sections 6.4 through 6.6 related to single-lane, multilane, and mini-roundabouts respectively.

Exhibit 6-1
General Design Process

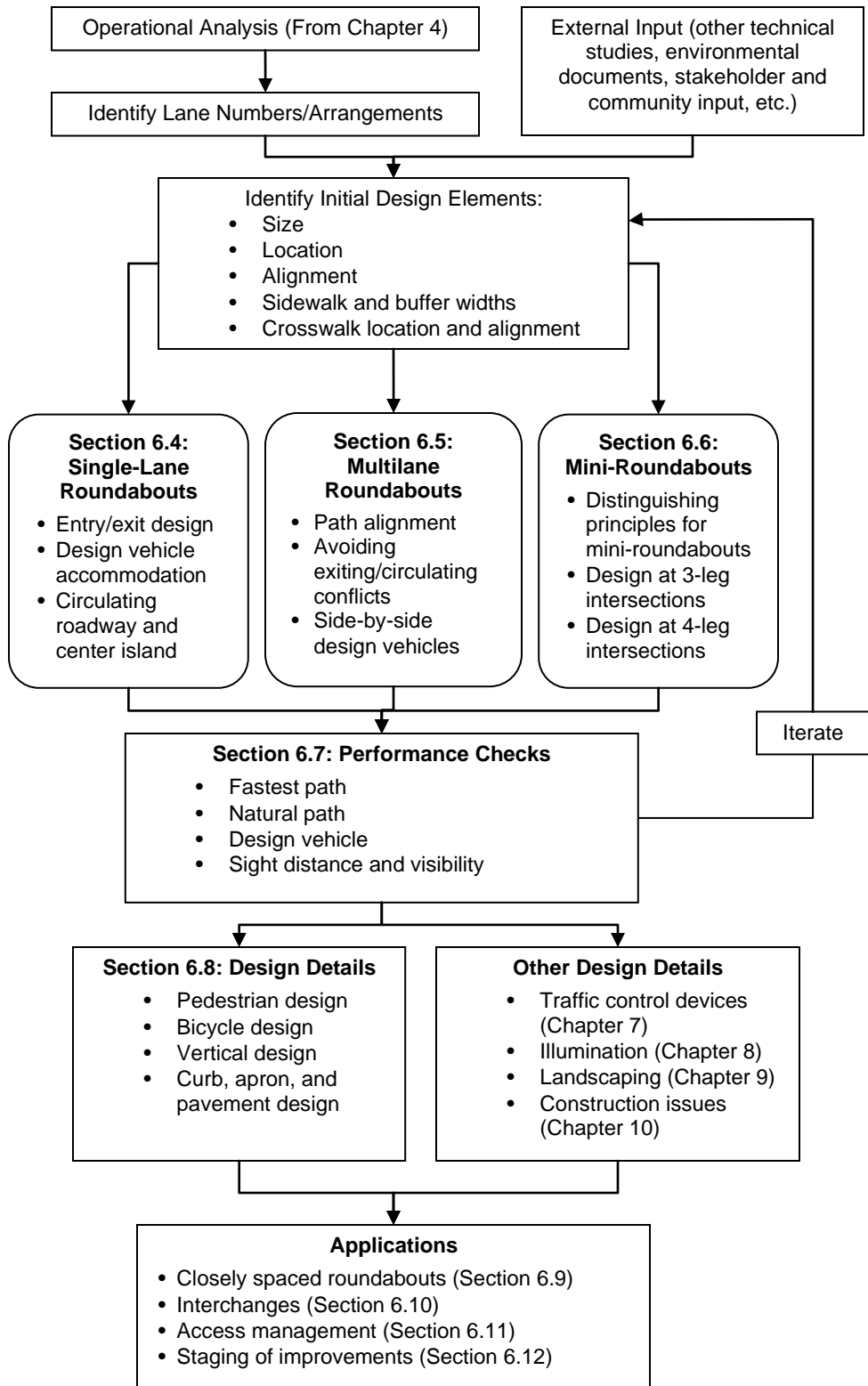

This chapter is organized such that the design principles common among all roundabout types are presented first. Even at the concept level, engineers are encouraged to develop designs that are consistent with the design principles in order to depict realistic impacts and to better define the required geometry. Poor concepts can lead to poor decision-making at the feasibility stage and can make it more difficult to generate large changes to a design at a later stage. More detailed design considerations specific to single-lane, multilane, and mini-roundabouts are given in subsequent sections of the chapter.

6.2 PRINCIPLES AND OBJECTIVES

This section describes the principles and objectives common to the design of all categories of roundabouts. Note that some features of multilane roundabout design are significantly different from single-lane roundabout design, and some techniques used in single-lane roundabout design may not directly transfer to multilane design. However, several overarching principles should guide the development of all roundabout designs.

Achieving these principles should be the goal of any roundabout design:

- Provide slow entry speeds and consistent speeds through the roundabout by using deflection.
- Provide the appropriate number of lanes and lane assignment to achieve adequate capacity, lane volume balance, and lane continuity.
- Provide smooth channelization that is intuitive to drivers and results in vehicles naturally using the intended lanes.
- Provide adequate accommodation for the design vehicles.
- Design to meet the needs of pedestrians and cyclists.
- Provide appropriate sight distance and visibility for driver recognition of the intersection and conflicting users.

Each of the principles described above affects the safety and operations of the roundabout. When developing a design, the trade-offs of safety, capacity, cost, and so on must be recognized and assessed throughout the design process. Favoring one component of design may negatively affect another. A common example of such a trade-off is accommodating large trucks on the roundabout approach and entry while maintaining slow design speeds. Increasing the entry width or entry radius to better accommodate a large truck may simultaneously increase the speeds that vehicles can enter the roundabout. Therefore, the engineer must balance these competing needs and may need to adjust the initial design parameters. To both accommodate the design vehicle and maintain slow speeds, additional design modifications could be required, such as offsetting the approach alignment to the left or increasing the inscribed circle diameter of the roundabout.

Exhibit 6-2 provides a review of the basic geometric features and key dimensions of a roundabout.

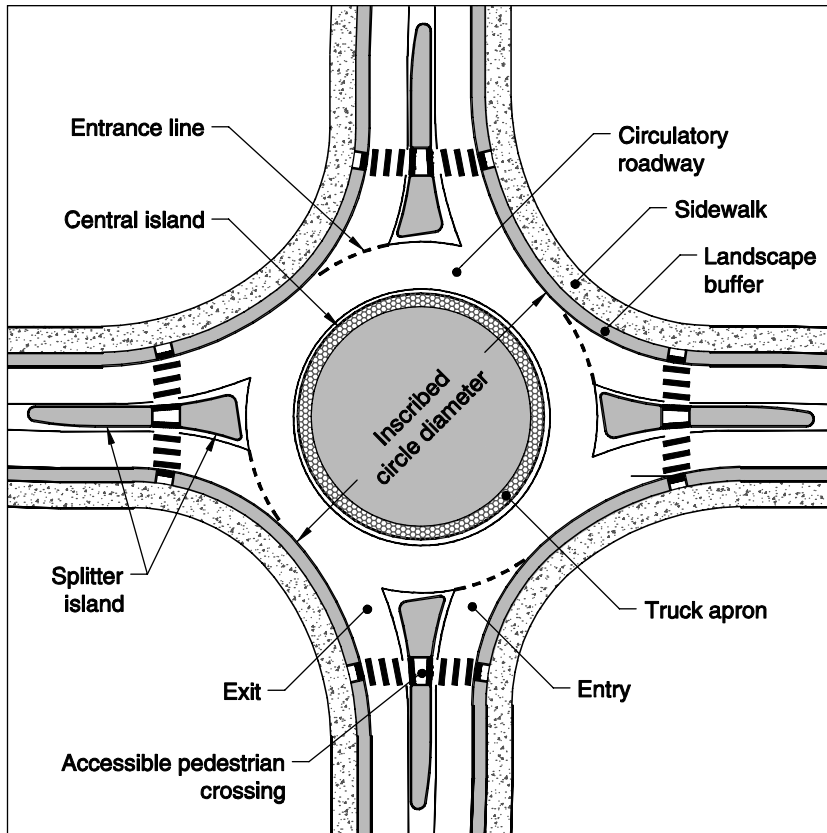

Exhibit 6-2
Basic Geometric Elements of
a Roundabout

6.2.1 SPEED MANAGEMENT

Achieving appropriate vehicular speeds for entering and traveling through the roundabout is a critical design objective as it has profound impacts on safety of all users; it also makes roundabouts easier to use and more comfortable for pedestrians and bicyclists. A well-designed roundabout reduces vehicle speeds upon entry and achieves consistency in the relative speeds between conflicting traffic streams by requiring vehicles to negotiate the roundabout along a curved path. Exhibit 6-3 shows an example of a roundabout where the approach alignment and entry geometry manage speeds entering the roundabout.

The operating speed of a roundabout is widely recognized as one of its most important attributes in terms of safety performance (1). Although the frequency of crashes is most directly tied to volume, the severity of crashes is most directly tied to speed. Therefore, careful attention to the design speed of a roundabout is fundamental to attaining good safety performance (2). Maximum entering design speeds based on a theoretical fastest path of 20 to 25 mph (32 to 40 km/h) are recommended at single-lane roundabouts. At multilane roundabouts, maximum entering design speeds of 25 to 30 mph (40 to 48 km/h) are recommended based on a theoretical fastest path assuming vehicles ignore all lane lines. These speeds are influenced by a variety of factors, including the geometry of the roundabout and the operating speeds of the approaching roadways. As a result, speed management is often a combination of managing speeds at the roundabout itself and managing speeds on the approaching roadways.

The most critical design objective is to maintain low and consistent speeds at the entry and through the roundabout.

Exhibit 6-3
Example of Using Geometry
to Manage Vehicle Speeds



Kennewick, Washington

International studies have shown that reducing the vehicle path radius at the entry (i.e., deflecting the vehicle path) decreases the relative speed between entering and circulating vehicles and thus results in lower entering–circulating vehicle crash rates. However, reducing the vehicle path radius at multilane roundabouts can, if not well designed, create poor path alignment (path overlap), greater side friction between adjacent traffic streams, and a higher potential for sideswipe crashes (3). Therefore, care must be taken in design to promote drivers naturally maintaining their lane. Guidance on measuring vehicle fastest path speeds is provided in Section 6.7.1.

In addition to achieving an appropriate design speed for the fastest movements, another important objective is to achieve consistent speeds for all movements. Along with overall reductions in speed, speed consistency can help to minimize the crash rate between conflicting streams of vehicles. This principle has two implications:

- The relative speeds between consecutive geometric elements should be minimized, and
- The relative speeds between conflicting traffic streams should be minimized.

6.2.2 LANE ARRANGEMENTS

Chapter 4 provides the methodologies for conducting an operational analysis for a roundabout. An outcome of that analysis is the required number of entry lanes to serve each of the approaches to the roundabout. For multilane roundabouts, care must be taken to ensure that the design also provides the appropriate number of lanes within the circulatory roadway and on each exit to ensure lane continuity.

Exhibit 6-4 illustrates a two-lane roundabout where the needed lane configurations on the eastbound approach are a left-turn and a shared left-through-right turn lane. For this lane configuration, two receiving lanes are needed within the circulatory roadway. However, the exit for the through movement must be a single lane to ensure proper lane configurations. If a second exit lane was provided heading eastbound, the result would be overlapping vehicle paths between exiting vehicles on the inside lane and left-turning vehicles that continue to circulate around the outside lane.

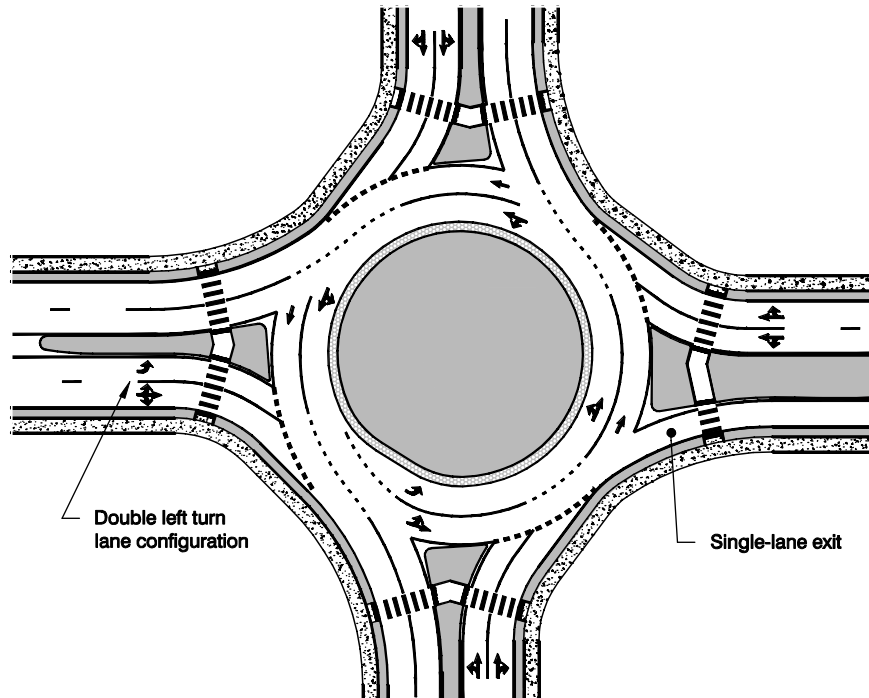

Exhibit 6-4
Lane Configuration Example

The allowed movements assigned to each entering lane are key to the overall design. Basic pavement marking layouts should be considered integral to the preliminary design process to ensure that lane continuity is being provided. In some cases, the geometry within the roundabout may be dictated by the number of lanes required or the need to provide spiral transitions (see Section 6.5 for more information). Lane assignments should be clearly identified on all preliminary designs in an effort to retain the lane configuration information through the various design iterations.

In some cases, a roundabout designed to accommodate design year traffic volumes, typically projected 20 years from the present, can result in substantially more entering, exiting, and circulating lanes than needed in the earlier years of operation. To maximize the potential safety during those early years of operation, the engineer may wish to consider a phased design solution that initially uses fewer entering and circulating lanes. As an example, the interim design would provide a single-lane entry to serve the near-term traffic volumes with the ability to cost-effectively expand the entries and circulatory roadway to accommodate future traffic volumes. To allow for expansion at a later phase, the ultimate configuration of the roundabout needs to be considered in the initial design. This requires that the ultimate horizontal and vertical design be identified to establish the outer envelope of the roundabout. Lanes are then removed from the ultimate design to provide the necessary capacity for the initial operation. This method helps to ensure that sufficient right-of-way is preserved and to minimize the degree to which the original roundabout must be rebuilt. Section 6.12 provides additional information on staging of improvements.

6.2.3 APPROPRIATE PATH ALIGNMENT

Path alignment at roundabouts draws parallels to conventional intersections and interchanges. At conventional intersections, drivers will tend to avoid driving immediately next to one another as they pass through small radius curves when

executing left or right turn movements. The same is true when drivers negotiate a two-lane loop ramp at an interchange. In both cases, the tendency to avoid traveling side-by-side is stronger when one of the vehicles is large like a truck. This overall behavior can also be seen at roundabouts. With this as background, engineers can nonetheless improve the operations and safety of a given multilane roundabout by paying attention to the path alignment of each traffic stream through it.

As two traffic streams approach the roundabout in adjacent lanes, vehicles will be guided by lane markings up to the entrance line. At the yield point, vehicles will continue along their natural trajectory into the circulatory roadway. The speed and orientation of the vehicle at the entrance line determines what can be described as its natural path. If the natural path of one lane interferes or overlaps with the natural path of the adjacent lane, the roundabout is not as likely to operate as safely or efficiently as possible. The geometry of the exits also affects the natural path that vehicles will travel. Overly small exit radii on multilane roundabouts may also result in overlapping vehicle paths on the exit.

A good multilane entry design aligns vehicles into the appropriate lane within the circulatory roadway. Likewise, the design of the exits should also provide appropriate alignment to allow drivers to intuitively maintain the appropriate lane. These alignment considerations often compete with the fastest path speed objectives.

Vehicle path overlap occurs when the natural path through the roundabout of one traffic stream overlaps the path of another. This can happen to varying degrees, and it can have varying consequences. For example, path overlap can reduce capacity because vehicles will avoid using one or more of the entry lanes. Path overlap can also create safety problems since the potential for sideswipe and single-vehicle crashes is increased. The most common type of path overlap is where vehicles in the left lane on entry are cut off by vehicles in the right lane due to inadequate entry path alignment, as shown in Exhibit 6-5. However, path overlap can also occur

Exhibit 6-5
Path Overlap at
a Multilane Roundabout

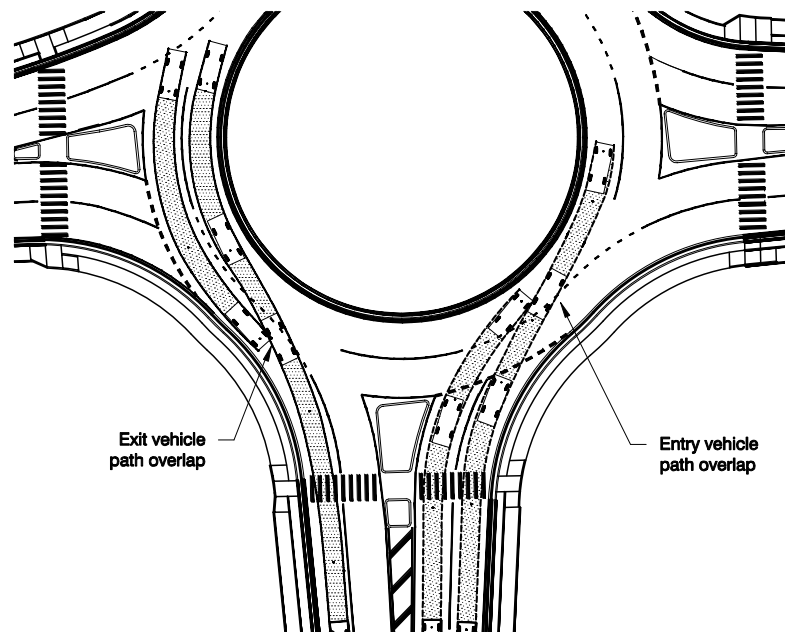

upon the exit from the roundabout where the exit radii are too small or the overall exit geometry does not adequately align the vehicle paths into the appropriate lane. Additional information on entry and exit design at multilane roundabouts is provided in Section 6.5.

6.2.4 DESIGN VEHICLE

Another important factor affecting a roundabout’s layout is the need to accommodate the largest vehicle likely to use the intersection. The turning path requirements of this vehicle, termed hereafter the *design vehicle*, will dictate many of the roundabout’s dimensions. Before beginning the design process, the engineer must be conscious of the design vehicle and possess the appropriate vehicle turning templates or a CAD-based vehicle turning path program to determine the vehicle’s swept path.

Because roundabouts are intentionally designed to slow traffic, narrow curb-to-curb widths and tight turning radii are typically used. However, if the widths and turning requirements are designed too tight, it can create difficulties for large vehicles. Large trucks and buses often dictate many of the roundabout’s dimensions, particularly for single-lane roundabouts. Therefore, it is very important to determine the design vehicle at the start of the design and investigation process.

Exhibit 6-6 illustrates an example of a single-lane roundabout that adequately accommodates the design vehicle. In this example, the tractor-trailer combination is accommodated using an apron within the central island. The apron provides additional paved surface to accommodate the wide path of the trailer, but keeps the actual circulatory roadway width narrow enough to maintain speed control for smaller passenger cars. As shown in the photo, the size of the roundabout also allows the cab of the truck to successfully navigate through the intersection without running over the outer curb lines.

The choice of design vehicle will vary depending on the approaching roadway types and the surrounding land use characteristics. The local or state agency with jurisdiction of the associated roadways should usually be consulted to identify the appropriate design vehicle for a given site. AASHTO’s *A Policy on Geometric Design*

The design vehicle dictates many of the roundabout’s dimensions.



Lothian, Maryland

Exhibit 6-6
Example of Roundabout
Designed for Large Trucks

of *Highways and Streets* provides the dimensions and turning path requirements for a variety of common highway vehicles (4).

Commonly, WB-50 (WB-15) vehicles are the largest vehicles along urban collectors and arterials. Larger trucks, such as WB-67 (WB-20) vehicles, may need to be addressed at intersections on interstate freeway or state highway systems. Smaller design vehicles may often be chosen at local street intersections. At a minimum, fire engines, transit vehicles, and single-unit delivery vehicles should be considered in urban areas, and it is desirable that these vehicles be accommodated without the use of the truck apron. In rural environments, farming or mining equipment may govern design vehicle needs.

Oversized vehicles (sometimes referred to as “superloads”) are another potential design vehicle that may require consideration in some locations, particularly in rural areas and at freeway interchanges. These oversized vehicles occur relatively infrequently and typically require a special permit for traveling on the roadway. However, at locations where an oversized vehicle is anticipated, special consideration for the size and tolerances of these vehicles will need to be provided in the design and construction.

6.2.5 NON-MOTORIZED DESIGN USERS

As with the motorized design vehicle, the design criteria of non-motorized potential roundabout users (e.g., bicyclists, pedestrians, skaters, wheelchair users, strollers) should be considered when developing many of the geometric components of a roundabout design. These users span a wide range of ages and abilities and can have a significant effect on the design of a facility. The basic design dimensions for various design users are given in Exhibit 6-7.

Section 6.8 provides additional detail regarding design for pedestrians and bicyclists. There are two general design issues that are most important for non-motorized users. First, slow motor vehicle speeds make roundabouts both easier to use and safer for non-motorized users. Therefore, the use of low design speeds is

Exhibit 6-7
Key Dimensions of Non-Motorized Design Users

User	Dimension	Affected Roundabout Features
Bicyclist		
Length	5.9 ft (1.8 m)	Splitter island width at crosswalk
Minimum operating width	4 ft (1.2 m)	Bike lane width on approach roadways; shared use path width
Pedestrian (walking)		
Width	1.6 ft (0.5 m)	Sidewalk width, crosswalk width
Wheelchair user		
Minimum width	2.5 ft (0.75 m)	Sidewalk width, crosswalk width
Operating width	3.0 ft (0.90 m)	Sidewalk width, crosswalk width
Person pushing stroller		
Length	5.6 ft (1.70 m)	Splitter island width at crosswalk
Skaters		
Typical operating width	6 ft (1.8 m)	Sidewalk width

Source: (5)

recommended in areas where pedestrians and cyclists are common. Second, as described elsewhere in this document, one-lane roundabouts are generally easier and safer for non-motorized users than multilane roundabouts. Therefore care should be taken to not design a multilane roundabout when a single lane roundabout is sufficient (see Chapter 3).

For non-motorized users, one important consideration during the initial design stage is to maintain or obtain adequate right-of-way outside the circulatory roadway for the sidewalks. All non-motorized users who are likely to use the sidewalk regularly, including bicyclists in situations where roundabouts are designed to provide bicycle access to sidewalks, should be considered in the design of the sidewalk width. In addition, as discussed in Section 6.8.1, a planter strip is recommended between the sidewalk and the circulatory roadway, so even more right-of-way may be necessary.

For pedestrians, one key consideration at the initial design stage is to ensure that adequate pedestrian refuge width is provided within the splitter island. The design width for a refuge area should be a minimum of 6 ft (1.8 m) to accommodate a typical bicycle or person pushing a stroller. Pedestrian crossings are typically provided approximately one car length behind the entrance line. Pedestrians should also be discouraged from crossing to the central island.

An important consideration at roundabouts is the accommodation of visually impaired pedestrians. Pedestrians with vision impairments face several challenges at roundabouts, as described in detail in Chapter 2. These challenges magnify the need to maintain slow vehicle speeds within the area of the crosswalk, to provide intuitive crosswalk alignments, and to provide design elements that encourage drivers to yield to pedestrians in a predictable manner.

Bicycle lanes should not be provided through the roundabout and should be terminated upstream of the entrance line. Bicycle users are encouraged to merge into the general travel lanes and navigate the roundabout as a vehicle. The typical vehicle operating speed within the circulatory roadway is in the range of 15 to 25 mph (24 to 40 km/h), which is similar to that of a bicycle. Multilane roundabouts are more challenging for bicyclists, so additional design features may be appropriate, as discussed in Section 6.8.

6.2.6 SIGHT DISTANCE AND VISIBILITY

The visibility of the roundabout as vehicles approach the intersection and the sight distance for viewing vehicles already operating within the roundabout are key components for providing safe roundabout operations. Similar in application to other intersection forms, roundabouts require two types of sight distance to be verified: (1) stopping sight distance and (2) intersection sight distance. The design should be checked to ensure that stopping sight distance can be provided at every point within the roundabout and on each entering and exiting approach such that a driver can react to objects or other conflicting users (such as pedestrians and bicyclists) within the roadway.

Intersection sight distance must also be verified for any roundabout design to ensure that sufficient distance is available for drivers to perceive and react to the presence of conflicting vehicles, pedestrians, and bicyclists. Intersection

sight distance is measured for vehicles entering the roundabout, with conflicting vehicles along the circulatory roadway and entering from the immediate upstream entry taken into account.

International evidence suggests that it is advantageous to provide no more than the minimum required intersection sight distance on each approach (6). Excessive intersection sight distance can lead to higher vehicle speeds that reduce the safety of the intersection for all road users (motorists, bicyclists, pedestrians). Landscaping within the central island can be effective in restricting sight distance to the minimum requirements while creating a terminal vista on the approach to improve visibility of the central island.

6.3 SIZE, POSITION, AND ALIGNMENT OF APPROACHES

The design of a roundabout involves optimizing three design decisions to balance the design principles and objectives established in Section 6.2. The design decisions are optimizing (1) size, (2) position, and (3) the alignment of the approach legs. There are numerous possible combinations of each element, each with its own advantages and disadvantages. Selection of the optimum combination will often be based upon the constraints of the project site balanced with the ability to adequately control vehicle speeds, accommodate heavy vehicles, and meet the other design objectives.

Exhibit 6-8 provides three possible combinations of roundabout position and approach alignment for a specific intersection. In each example, the size of the inscribed circle has remained fixed. As can be imagined, many other

Three key design decisions are optimizing size, position, and the alignment of the approach legs.

Exhibit 6-8
Example of Sketch Iterations

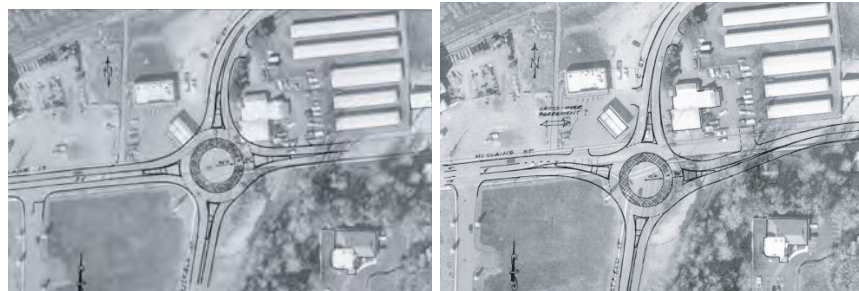

(a) Centered on Existing Intersection

(b) Center Shifted to the South



(c) Center Shifted to the East

possible alternatives could be developed by varying the size of the inscribed circle diameter.

Each of the alternatives shown in Exhibit 6-8 results in different impacts to the adjacent properties. Producing sketch-level designs of several alternatives aids the engineer in identifying these impacts and better evaluating the range of options that are available. It is important to note that where the location of the roundabout has been shifted from the center of the existing intersection, the approach alignments also require adjustment to achieve more perpendicular entries and to achieve speed control.

6.3.1 INSCRIBED CIRCLE DIAMETER

The inscribed circle diameter is the distance across the circle inscribed by the outer curb (or edge) of the circulatory roadway, as illustrated previously in Exhibit 6-2. It is the sum of the central island diameter and twice the circulatory roadway width. The inscribed circle diameter is determined by a number of design objectives, including accommodation of the design vehicle and providing speed control, and it may require iterative experimentation. Once a sketch-level design concept has been completed, the engineer is encouraged to look critically at the design to identify whether the initial assumed diameter produces a desired outcome (e.g., acceptable speeds, adequately serving the design vehicle, appropriate visibility for the central island) or whether a larger or smaller diameter would be beneficial.

At single-lane roundabouts, the size of the inscribed circle is largely dependent upon the turning requirements of the design vehicle. The diameter must be large enough to accommodate the design vehicle while maintaining adequate deflection curvature to ensure safe travel speeds for smaller vehicles. However, the circulatory roadway width, entry and exit widths, entry and exit radii, and entry and exit angles also play a significant role in accommodating the design vehicle and providing deflection. Careful selection of these geometric elements may allow a smaller inscribed circle diameter to be used in constrained locations. The inscribed circle diameter typically needs to be at least 105 ft (32 m) to accommodate a WB-50 (WB-15) design vehicle. Smaller roundabouts can be used for some local street or collector street intersections, where the design vehicle may be a bus or single-unit truck. For locations that must accommodate a larger WB-67 (WB-20) design vehicle, a larger inscribed circle diameter will be required, typically in the range of 130 to 150 ft (40 to 46 m). In situations with more than four legs, larger inscribed circle diameters may be appropriate. Truck aprons are typically needed to keep the inscribed circle diameter reasonable while accommodating the larger design vehicles.

At multilane roundabouts, the size of the roundabout is usually determined by balancing the need to achieve deflection with providing adequate alignment of the natural vehicle paths. Typically, achieving both of these critical design objectives requires a slightly larger diameter than used for single-lane roundabouts. Generally, the inscribed circle diameter of a multilane roundabout ranges from 150 to 250 ft (46 m to 76 m). For two-lane roundabouts, a common starting point is 160 to 180 ft (49 to 55 m). Roundabouts with three- or four-lane entries may require larger diameters of 180 to 330 ft (55 to 100 m) to achieve adequate speed control and

Selection of an inscribed circle diameter is generally the first step in the design process. After completion of a concept design, a critical eye should be given to evaluating whether the initial assumed diameter is optimal.

The inscribed circle diameter must be large enough to accommodate the design vehicle while maintaining slower speeds for small vehicles.

The inscribed circle diameter for a single-lane roundabout typically needs to be at least 105 ft (32 m) to accommodate a WB-50 (WB-15) design vehicle; a larger diameter is typically needed for design vehicles larger than a WB-50 (WB-15).

Diameters in the range of 120 to 140 ft (36 to 43 m) are common starting points for single-lane roundabouts.

For a two-lane roundabout, the minimum inscribed circle diameter is typically 150 ft (46 m). Diameters in the range of 160 to 180 ft (49 to 55 m) are common starting points for two-lane roundabout design.

alignment (7). Truck aprons are sometimes needed to keep the inscribed circle diameter reasonable while accommodating the larger design vehicles.

Mini-roundabouts serve as a special subset of roundabouts and are defined by their small inscribed circle diameters. With a diameter less than 90 ft, the mini-roundabout is smaller than the typical single-lane roundabout. The small diameter is made possible by the use of a fully traversable central island to accommodate large vehicles, as opposed to the typical single-lane roundabout where the diameter must be large enough to accommodate a heavy vehicle within the circulatory roadway (and truck apron if applicable) without it needing to travel over the central island. The small footprint of a mini-roundabout offers flexibility in working within constrained sites. However, as described in Section 6.6, it also has limitations to where it may be appropriate due to the reduced ability control speeds with the traversable central island. Trade-offs of using the smaller diameter mini-roundabout versus the larger-diameter typical single-lane roundabout should be considered based upon the unique site conditions.

Exhibit 6-9 provides typical ranges of inscribed circle diameters for various site locations.

Exhibit 6-9
Typical Inscribed Circle
Diameter Ranges

Roundabout Configuration	Typical Design Vehicle	Common Inscribed Circle Diameter Range*	
Mini-Roundabout	SU-30 (SU-9)	45 to 90 ft	(14 to 27 m)
Single-Lane Roundabout	B-40 (B-12)	90 to 150 ft	(27 to 46 m)
	WB-50 (WB-15)	105 to 150 ft	(32 to 46 m)
	WB-67 (WB-20)	130 to 180 ft	(40 to 55 m)
Multilane Roundabout (2 lanes)	WB-50 (WB-15)	150 to 220 ft	(46 to 67 m)
	WB-67 (WB-20)	165 to 220 ft	(50 to 67 m)
Multilane Roundabout (3 lanes)	WB-50 (WB-15)	200 to 250 ft	(61 to 76 m)
	WB-67 (WB-20)	220 to 300 ft	(67 to 91 m)

* Assumes 90° angles between entries and no more than four legs. List of possible design vehicles is not all-inclusive.

For initial selection of an inscribed circle diameter using Exhibit 6-9, the intersection design vehicle and the context of the location should be taken into consideration. For instance, in a constrained urban location, selection of a diameter at the low end of the identified range may be needed due to right-of-way constraints but may not allow for the same degree of deflection and speed control as would a larger diameter. Conversely, in a higher-speed rural location, a larger-diameter roundabout may have a larger footprint but may be required to accommodate large trucks while providing increased visibility and speed control.

6.3.2 ALIGNMENT OF APPROACHES

The alignment of the approach legs plays an important role in the design of a roundabout. The alignment affects the amount of deflection (speed control) that is achieved, the ability to accommodate the design vehicle, and the visibility angles to adjacent legs. The optimal alignment is generally governed by the size and position of the roundabout relative to its approaches. Various options for approach alignment are summarized in Exhibit 6-10.

Roundabout approach alignments should generally pass to the left or through the center of the inscribed circle.

Exhibit 6-10
Entry Alignment Alternatives

Entry Alignment

Question

Should the approach alignment run through the center of the inscribed circle? Or is it acceptable to offset the approach centerline to one side?

Design Principle

The alignment does not have to pass through the center of the roundabout; however, it has a primary effect on the entry/exit design. The optimal alignment allows for an entry design that provides adequate deflection and speed control while also providing appropriate view angles to drivers and balancing property impacts/costs.

Alternative 1: Offset Alignment to the Left of Center

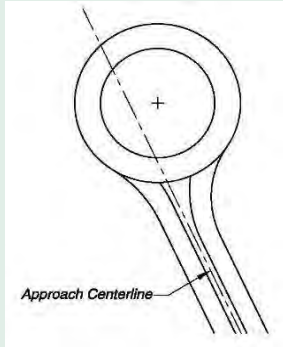

ADVANTAGES:

- Allows for increased deflection
- Beneficial for accommodating large trucks with small inscribed circle diameter—allows for larger entry radius while maintaining deflection and speed control
- May reduce impacts to right-side of roadway

TRADE-OFFS

- Increased exit radius or tangential exit reduces control of exit speeds and acceleration through crosswalk area
- May create greater impacts to the left side of the roadway

Alternative 2: Alignment through Center of Roundabout

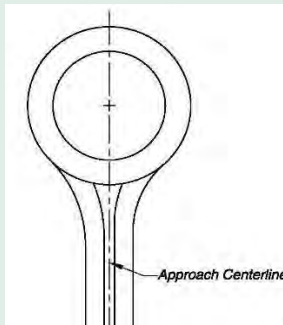

ADVANTAGES:

- Reduces amount of alignment changes along the approach roadway to keep impacts more localized to intersection
- Allows for some exit curvature to encourage drivers to maintain slower speeds through the exit

TRADE-OFFS

- Increased exit radius reduces control of exit speeds/acceleration through crosswalk area
- May require a slightly larger inscribed circle diameter (compared to offset-left design) to provide the same level of speed control

Alternative 3: Alignment to Right of Center

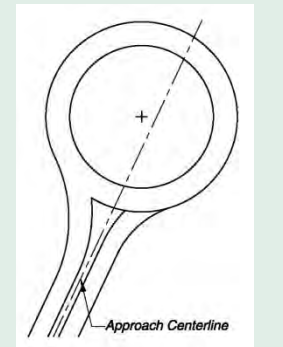

ADVANTAGES:

- Could be used for large inscribed circle diameter roundabouts where speed control objectives can still be met
- Although not commonly used, this strategy may be appropriate in some instances (provided that speed objectives are met) to minimize impacts, improve view angles, etc.

TRADE-OFFS

- Often more difficult to achieve speed control objectives, particularly at small diameter roundabouts
- Increases the amount of exit curvature that must be negotiated

A common starting point in design is to center the roundabout so that the centerline of each leg passes through the center of the inscribed circle (radial alignment). This location typically allows the geometry of a single-lane roundabout to be adequately designed such that vehicles will maintain slow speeds through both the entries and the exits. The radial alignment also makes the central island more conspicuous to approaching drivers and minimizes roadway modification required upstream of the intersection.

Another frequently acceptable alternative is to offset the centerline of the approach to the left (i.e., the centerline passes to the left of the roundabout's center point). This alignment will typically increase the deflection achieved at the entry to improve speed control. However, engineers should recognize the inherent trade-off of a larger radius (or tangential) exit that may provide less speed control for the downstream pedestrian crossing. Especially in urban environments, it is important to have drivers maintain sufficiently low vehicular speeds at the pedestrian crossing to reduce the risk for pedestrians. The fastest-path procedure provided in Section 6.7.1 identifies a methodology for estimating speeds for large radius (or tangential) exits where acceleration may govern the attainable speed.

Approach alignments that are offset to the right of the roundabout's center point typically do not achieve satisfactory results, primarily due to a lack of deflection and lack of speed control that result from this alignment. An offset-right alignment brings the approach in at a more tangential angle and reduces the opportunity to provide sufficient entry curvature. Vehicles will usually be able to enter the roundabout too fast, resulting in more loss-of-control crashes and higher crash rates between entering and circulating vehicles. However, an offset-right alignment alone should not be considered a fatal flaw in a design if speed requirements and other design considerations can be met.

6.3.3 ANGLE BETWEEN APPROACH LEGS

Similar to signalized and stop-controlled intersections, the angle between approach legs is also an important design consideration. Although it is not necessary for opposing legs to align directly opposite one another (as it is for conventional intersections), it is generally preferable for the approaches to intersect at perpendicular or near-perpendicular intersection angles. If two approach legs intersect at an angle significantly greater than 90° , it will often result in excessive speeds for one or more right-turn movements. Alternatively, if two approach legs intersect at an angle significantly less than 90° , then the difficulty for large trucks to successfully navigate the turn is increased. Providing a large corner radius to accommodate trucks may result in a wide portion of circulatory roadway resulting in increased speeds and may also lead to reduced safety performance if the circulatory roadway width is mistakenly interpreted by drivers to be two lanes. Designing the approaches at perpendicular or near-perpendicular angles generally results in relatively slow and consistent speeds for all movements. Highly skewed intersection angles can often require significantly larger inscribed circle diameters to achieve the speed objectives (8).

Exhibit 6-11 illustrates the fastest paths at a roundabout with perpendicular approach angles versus a roundabout with obtuse approach angles. As this figure implies, it is desirable for roundabout T-intersections to intersect as close to 90° as

Exhibit 6-11
Angle between Legs

Angle between Approach Legs

Question

Is it acceptable to have a skewed angle between intersection legs or do the angles always need to be perpendicular?

Design Principle

The angle between legs may affect the ability to achieve slow fastest-path speeds, may affect navigation of large vehicles, and can complicate the signing and marking. In general, it will be easier to achieve the design objectives if the approach legs are nearly perpendicular to each other. However, perpendicular approaches are not a design requirement. Acceptable designs can be achieved with skewed angles between approaches with corresponding adjustments to other design components.

Perpendicular Legs

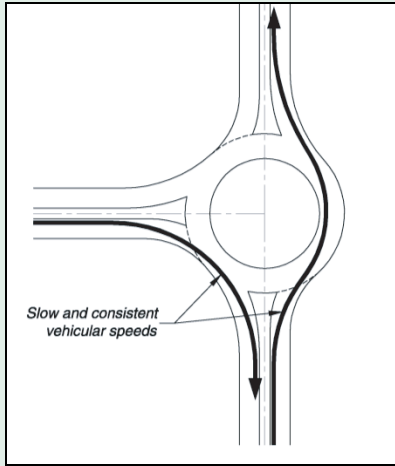

Perpendicular approach angles will generally provide slow and consistent speeds when used in combination with other appropriately sized design features. Achieving acceptable fastest-path speeds is often easier to accomplish with a perpendicular approach angle than with a skew.

Where the intersecting roadways are skewed under existing conditions, realignment of one or more approach legs would be required to achieve this ideal condition. The ability to realign a leg may depend on other site constraints and may not be feasible in all locations. Realigning to achieve an angle as close to 90 degrees as practical is generally desirable.

Large Angle between Legs

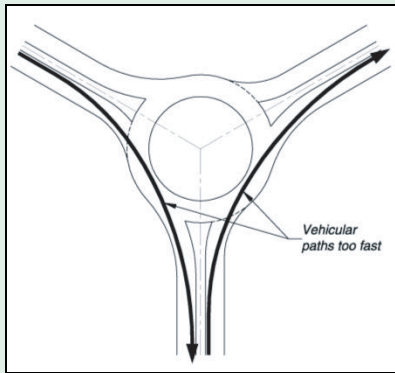

In situations involving a large angle between legs, it is desirable to realign one or more legs to try to achieve a more perpendicular condition. Large angles make it difficult to provide adequate deflection and may result in fast vehicle speeds, particularly for the right-turn movements.

Options to achieve adequate speed control without realignment of the approaches include but are not limited to the following:

- Changing the inscribed circle diameter
- Offsetting the approach centerline to the left of the center of the roundabout
- Reducing entry widths and entry radii

possible. Y-shaped intersection alignments have the potential for higher speeds than desired. Approaches that intersect at angles greater than approximately 105° can be realigned by introducing curvature in advance of the roundabout to produce a more perpendicular intersection. Other possible geometric modifications include changes to the inscribed circle diameter or modifications to the shape of the central island to manage vehicle speeds. For roundabouts in low-speed urban environments, the alignment of the approaches may be less critical.

6.4 SINGLE-LANE ROUNDABOUTS

This section presents specific parameters and guidelines for the design of individual geometric elements at a single-lane roundabout. Many of these same principles also apply to the design of multilane roundabouts; however, there are some additional complexities to the design of multilane roundabouts that are described in detail in Section 6.5. Individual geometric components are not independent of each other; the interaction between the components of the geometry is more important than the individual pieces. Care must be taken to provide compatibility between the geometric elements to meet overall safety and capacity objectives.

Once an initial inscribed diameter, roundabout location, and approach alignment are identified, the design can be more fully developed to include establishing the entry widths, circulatory roadway width, and initial entry and exit geometry. These additional details are described within this section. Once the initial designs for the entries and exits on each approach have been laid out, performance checks should be undertaken to evaluate the design versus the principles (including fastest path and design vehicle accommodation) to identify any required design refinements. Based on the performance checks, it may be necessary to perform design iterations to adjust the inscribed circle diameter, approach alignments, roundabout location, and/or entry and exit design to improve the composition of the design.

6.4.1 SPLITTER ISLANDS

Splitter islands (also called *separator islands*, *divisional islands*, or *median islands*) should be provided on all single-lane roundabouts. Their purpose is to provide refuge for pedestrians, assist in controlling speeds, guide traffic into the roundabout, physically separate entering and exiting traffic streams, and deter wrong-way movements. Additionally, splitter islands can be used as a place for mounting signs (see Chapter 7).

When performing the initial layout of a roundabout's design, a sufficiently sized splitter island envelope should be identified prior to designing the entry and exits of an approach. This will ensure that the design will eventually allow for a raised island that meets the minimum dimensions (offsets, tapers, length, widths). It is recommended that control points for the splitter island envelope be identified prior to proceeding to the design of the entry and exit geometry to ensure that a properly sized splitter island will be provided.

The total length of the raised island should generally be at least 50 ft (15 m), although 100 ft (30 m) is desirable, to provide sufficient protection for pedestrians and to alert approaching drivers to the geometry of the roundabout. On higher speed roadways, splitter island lengths of 150 ft (45 m) or more are often beneficial. Additionally, the splitter island should extend beyond the end of the exit curve to prevent exiting traffic from accidentally crossing into the path of approaching traffic. The splitter island width should be a minimum of 6 feet (1.8 m) at the crosswalk to adequately provide refuge for pedestrians, including those using wheelchairs, pushing a stroller, or walking a bicycle.

Splitter islands perform multiple functions and should be provided.

The recommended minimum length for a splitter island is 50 ft to provide adequate visibility and refuge.

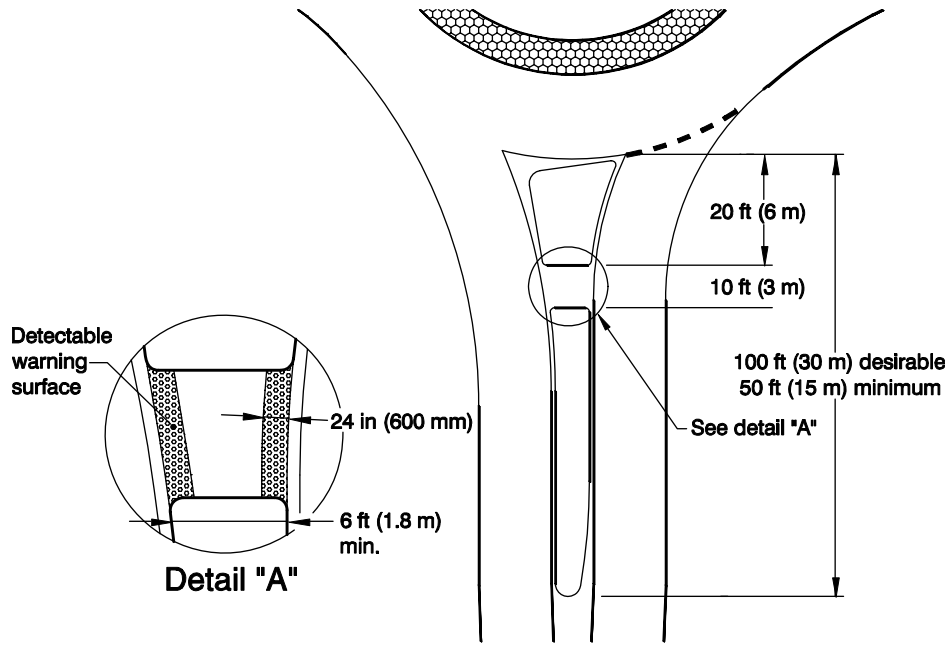

Exhibit 6-12
Minimum Splitter Island
Dimensions

Exhibit 6-12 shows the minimum dimensions for a splitter island at a single-lane roundabout, including the location of the pedestrian crossing.

While the above diagram provides minimum dimensions for splitter islands, there are benefits to providing larger islands. An increase in the splitter island width results in greater separation between the entering and exiting traffic streams of the same leg and increases the time for approaching drivers to distinguish between exiting and circulating vehicles. In this way, larger splitter islands can help reduce confusion for entering motorists. A study by the Queensland Department of Main Roads found that maximizing the width of splitter islands has a significant effect on minimizing entering/circulating vehicle crash rates (3). However, increasing the width of the splitter islands generally requires increasing the inscribed circle diameter in order to maintain speed control on the approach. Thus, these safety benefits may be offset by higher construction cost and greater land impacts.

Standard AASHTO guidelines for island design should be followed for the splitter island. This includes using larger nose radii at approach corners to maximize island visibility and offsetting curb lines at the approach ends to create a funneling effect. The funneling treatment also aids in reducing speeds as vehicles approach the roundabout. Exhibit 6-13 shows typical minimum splitter island nose radii and offset dimensions from the entry and exit traveled ways.

Alternative splitter island designs have been adopted by some states to meet local design preferences or climate conditions. For instance, some states use features such as sloped approach noses, unique curb shapes, and specifications for sloping the top surface of the island outward. Local design standards should be followed in locations where more specific guidance has been adopted.

Use care during the initial design to provide a sufficiently large splitter island envelope that will allow for the final raised island to meet the minimum dimensions shown in Exhibit 6-12 and Exhibit 6-13.

Wide splitter islands enhance safety, but may require that the inscribed circle diameter be increased.

Exhibit 6-13
 Typical Minimum Splitter
 Island Nose Radii and Offsets

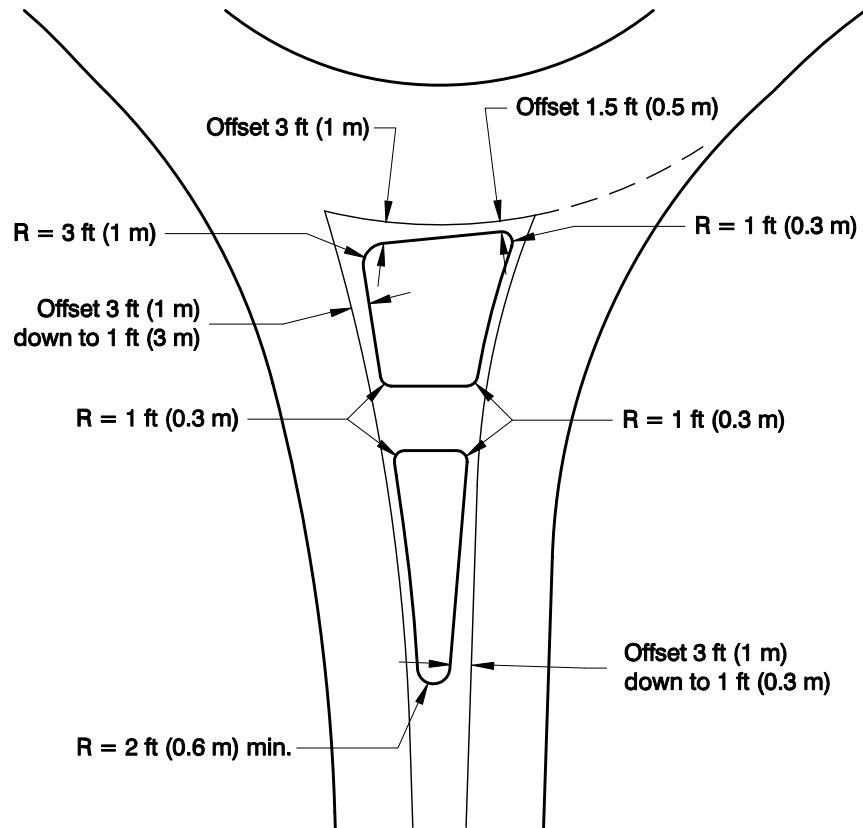

6.4.2 ENTRY WIDTH

Entry width is measured from the point where the entrance line intersects the left edge of traveled way to the right edge of the traveled way, along a line perpendicular to the right curb line. The width of each entry is dictated by the needs of the entering traffic stream, principally the design vehicle. However, this needs to be balanced against other performance objectives including speed management and pedestrian crossing needs.

Typical entry widths for single-lane entrances range from 14 to 18 ft (4.2 to 5.5 m); these are often flared from upstream approach widths. However, values higher or lower than this range may be appropriate for site-specific design vehicle and speed requirements for critical vehicle paths. A 15 ft (4.6 m) entry width is a common starting value for a single-lane roundabout. Care should be taken with entry widths greater than 18 ft or for those that exceed the width of the circulatory roadway, as drivers may mistakenly interpret the wide entry to be two lanes when there is only one receiving circulatory lane.

6.4.3 CIRCULATORY ROADWAY WIDTH

The required width of the circulatory roadway is determined from the number of entering lanes and the turning requirements of the design vehicle. Except opposite a right-turn-only lane, the circulating width should be at least as wide as the maximum entry width and up to 120% of the maximum entry width. For single-lane roundabouts, the circulatory roadway width usually remains constant

throughout the roundabout (9). Typical circulatory roadway widths range from 16 to 20 ft for single-lane roundabouts. Care should be taken to avoid making the circulatory roadway width too wide within a single-lane roundabout because drivers may think that two vehicles are allowed to circulate side-by-side.

At single-lane roundabouts, the circulatory roadway width should be comfortable for passenger car vehicles and should be wide enough to accommodate a design vehicle up to a bus at a small roundabout. There may be some operational benefit to accommodating a WB-50 (WB-15) within the circulatory roadway at a single-lane urban arterial roundabout to allow somewhat faster circulating speeds. A truck apron will often need to be provided within the central island to accommodate larger design vehicles (including the common WB-62 (WB-19), WB-65 (WB-20), or WB-67 (WB-20) design vehicles) but maintain a relatively narrow circulatory roadway to adequately constrain vehicle speeds. Additional discussion of truck aprons is provided in Section 6.4.7.1. Appropriate templates or a CAD-based computer program should be used to determine the swept path of the design vehicle through each of the turning movements. Usually, the left-turn movement is the critical path for determining circulatory roadway width. In accordance with AASHTO policy, a minimum clearance of 1 ft (0.3 m) and preferably 2 ft (0.6 m) should be provided between the outside edge of the vehicle's tire track and the curb line.

6.4.4 CENTRAL ISLAND

The central island of a roundabout is the raised, mainly non-traversable area surrounded by the circulatory roadway. It may also include a traversable truck apron. The island is typically landscaped for aesthetic reasons and to enhance driver recognition of the roundabout upon approach. Raised central islands for single-lane roundabouts are preferred over depressed central islands, as depressed central islands are difficult for approaching drivers to recognize and drainage can be an issue.

A circular central island is preferred because the constant-radius circulatory roadway helps promote constant speeds around the central island. Oval or irregular shapes, on the other hand, can promote higher speeds on the flatter arc sections and reduced speeds on the tighter arc sections, depending on the lengths of those sections. However, oval shapes may be necessary at irregularly shaped intersections or intersections with more than four legs. Oval shapes are generally not such a problem if they are relatively small and speeds are low. Raindrop-shaped islands may be used in areas where certain movements do not exist, such as interchanges (see Section 6.10), or at locations where certain turning movements cannot be safely accommodated, such as roundabouts with one approach on a relatively steep grade.

The size of the central island plays a key role in determining the amount of deflection imposed on the through vehicle's path. However, its diameter is dependent upon the inscribed circle diameter and the required circulatory roadway width (see Sections 6.3.1 and 6.4.3, respectively). Roundabouts in rural environments typically need larger central islands than urban roundabouts to enhance their visibility, accommodate larger design vehicles, enable better approach geometry to be designed in the transition from higher speeds, and be more forgiving to errant vehicles (3).

Circular central islands are preferable to oval or irregular shapes, but noncircular shapes are sometimes necessary.

Raindrop-shaped central islands may be used where certain movements do not exist, such as at interchanges.

Landscaping and other treatments within the central island are discussed in Chapter 8.

6.4.5 ENTRY DESIGN

As shown in Exhibit 6-14, the entry is bounded by a curb or edge of pavement consisting of one or more curves leading into the circulatory roadway. It should not be confused with the *entry path curve*, defined by the fastest vehicular travel path through the entry geometry (measured by R_1 in 6). At single-lane roundabouts, a single entry curb radius is typically adequate; for approaches on higher speed roadways, the use of compound curves may improve guidance by lengthening the entry arc.

Exhibit 6-14
Single-Lane Roundabout
Entry Design

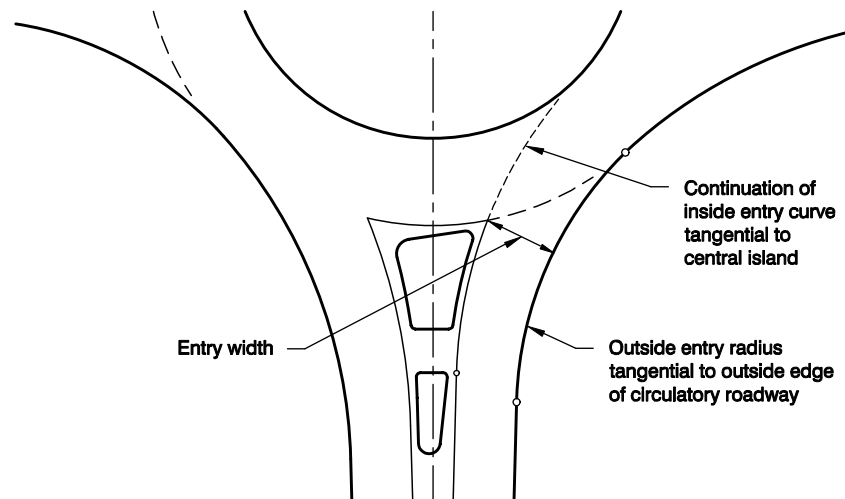

The entry curb radius is an important factor in determining the operation of a roundabout because it affects both capacity and safety. The entry curb radius, in conjunction with the entry width, the circulatory roadway width, and the central island geometry, controls the amount of deflection imposed on a vehicle’s entry path. Excessively large entry curb radii have a higher potential to produce faster entry speeds than desired. Care should also be taken to avoid entry curb radii that are too abrupt since these may lead to single-vehicle crashes. Guidance from the United Kingdom indicates that small entry curb radii, below 50 ft (15 m), may reduce the capacity of the entry; however, entry curb radii that are 65 ft (20 m) or greater have little effect on the roundabout capacity (9, 10). Anecdotally, larger entry curb radii may allow for higher speeds and therefore could increase the entry capacity under low conflicting flow rates.

As with the other components of a roundabout design, a wide range of entry curb radii may be appropriate depending upon the other components of the design. The primary goal in selecting the entry curb radius is to achieve the speed objectives, as described in Section 6.2. The entry curb radius should produce an appropriate design speed on the fastest vehicular path. At single-lane roundabouts, it is relatively simple to achieve the entry speed objectives. With a single traffic stream entering and circulating, there is no conflict between traffic in adjacent lanes. Thus, the entry curb radius can be reduced or increased as necessary to produce the

desired entry path radius. Provided sufficient clearance is given for the design vehicle, approaching vehicles will adjust their path accordingly and negotiate through the entry geometry into the circulatory roadway. The outside curb line of the entry is commonly designed curvilinearly tangential to the outside edge of the circulatory roadway. Likewise, the projection of the inside (left) edge of the entry roadway is commonly curvilinearly tangential to the central island. Exhibit 6-14 shows a typical single-lane roundabout entrance design.

Entry radii at urban single-lane roundabouts typically range from 50 to 100 ft (15 to 30 m). A common starting point is an entry radius in the range of 60 to 90 ft; however, a larger or smaller radius may be needed to accommodate large vehicles or serve small diameter roundabouts, respectively. Larger radii may be used, but it is important that the radii not be so large as to result in excessive entry speeds.

The entry geometry should provide adequate horizontal curvature to channelize drivers into the circulatory roadway to the right of the central island. It is also often desirable for the splitter island to have enough curvature to block a direct path to the central island for approaching vehicles. This helps to avoid vehicles errantly hitting the central island and also further discourages drivers from making a wrong-way left-turn maneuver. Exhibit 6-16 illustrates an alternative method for increasing the amount of entry deflection.

Another important principle in the design of an entry is sight distance and visibility, as discussed in Section 6.2.6. The angle of visibility to the left must be adequate for entering drivers to comfortably view oncoming traffic from the immediate upstream entry or from the circulatory roadway. Additional details on measuring angles of visibility are provided in Section 6.7.4. A useful surrogate used by some practitioners for capturing the effects of entry speed, path alignment, and visibility to the left is entry angle (ϕ). Typical entry angles are between 20° and 40° . Additional detail on entry angle can be found in the Wisconsin Department of Transportation Roundabout Guide (7) and design guidance from the United Kingdom (9–10). In general, entry angles that are too severe produce poor angles of visibility to the left, requiring drivers to strain to look over their shoulders, and may encourage merging behavior similar to freeway on-ramps. Meanwhile entry angles that are too shallow may not provide enough positive alignment to discourage wrong-way movements.

At rural and suburban locations, consideration should be given to the speed differential between the approaches and entries. If the difference is greater than 12 mph (20 km/h), it may be desirable to introduce geometric or cross-sectional features to reduce the speed of approaching traffic prior to the entry curvature. Further details on roundabout design in high-speed environments are provided in Section 6.8.

6.4.6 EXIT DESIGN

The exit curb radii are usually larger than the entry curb radii in order to minimize the likelihood of congestion and crashes at the exits. This, however, is balanced by the need to maintain slow speeds through the pedestrian crossing on exit. The exit design is also influenced by the design environment (urban versus rural), pedestrian demand, the design vehicle, and physical constraints.

The exit curb is commonly designed to be curvilinearly tangential to the outside edge of the circulatory roadway. Likewise, the projection of the inside (left) edge of the exit roadway is commonly curvilinearly tangential to the central island. Generally, exit curb radii should be no less than 50 ft (15 m), with values of 100 to 200 ft (30 to 60 m) being more common. Exhibit 6-15 shows a typical exit layout for a single-lane roundabout.

Exhibit 6-15
Single-Lane Roundabout
Curvilinear Exit Design

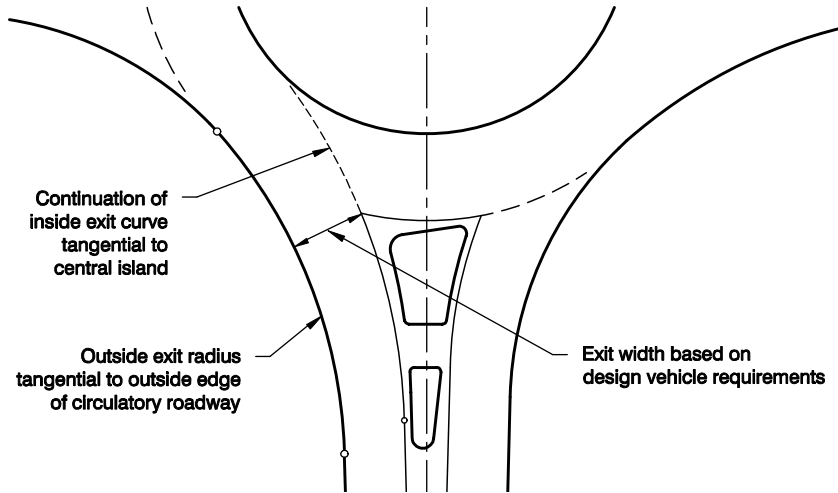

For designs using an offset-left approach alignment, the exit design may require much larger radii, ranging from 300 to 800 ft (91 to 244 m) or greater (11). Larger exit radii may also be desirable in areas with high truck volumes to provide ease of navigation for trucks and reduce the potential for trailers to track over the outside curb (see Exhibit 6-19). These radii may provide acceptable speed through the pedestrian crossing area given that the acceleration characteristics of the vehicles will result in a practical limit to the speeds that can be achieved on the exit. However, the fastest-path methodology presented in Section 6.7 can be used to verify the exit speed. A large-radius or tangential type exit design is illustrated in Exhibit 6-16.

Exhibit 6-16
Single-Lane Roundabout
Large Radius Exit Design

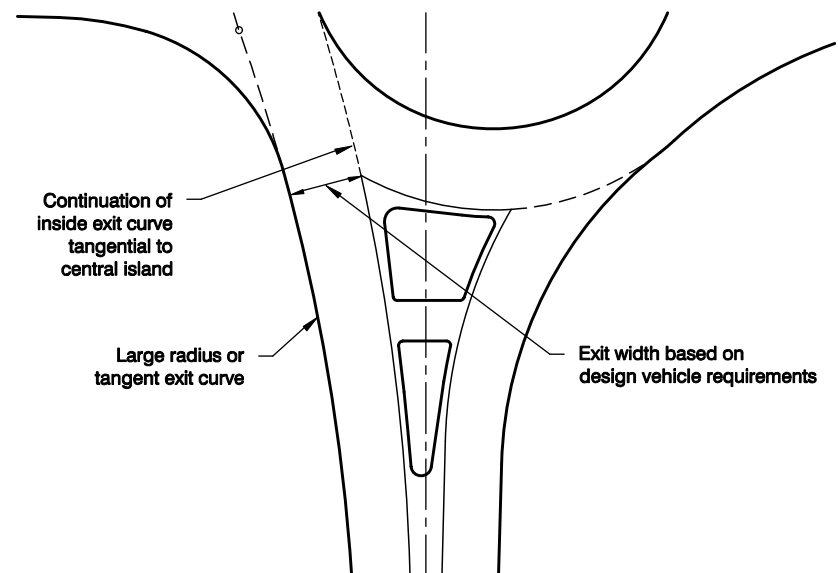

At single-lane roundabouts in urban environments, exits should be designed to enforce slow exit path speeds to maximize safety for pedestrians crossing the exiting traffic stream. Pedestrian activity should be considered at all exits except where separate pedestrian facilities (grade separated paths, etc.) or other restrictions eliminate the likelihood of pedestrian activity in the foreseeable future.

Similar to entry design, exit design flexibility is required to achieve the optimal balance between competing design variables and project objectives to provide adequate capacity and essential safety (for all modes) while minimizing excessive property impacts and costs. The selection of a curved versus tangential design will be based upon the balancing of each of these criteria.

6.4.7 DESIGN VEHICLE CONSIDERATIONS

Within a single-lane roundabout, the design vehicle is typically the controlling factor for most dimensions, including the inscribed circle diameter, entry width, entry radius, and circulatory roadway width. Exhibit 6-17 and Exhibit 6-18 demonstrate the use of a CAD-based computer program to determine the vehicle’s swept path through the critical turning movements.

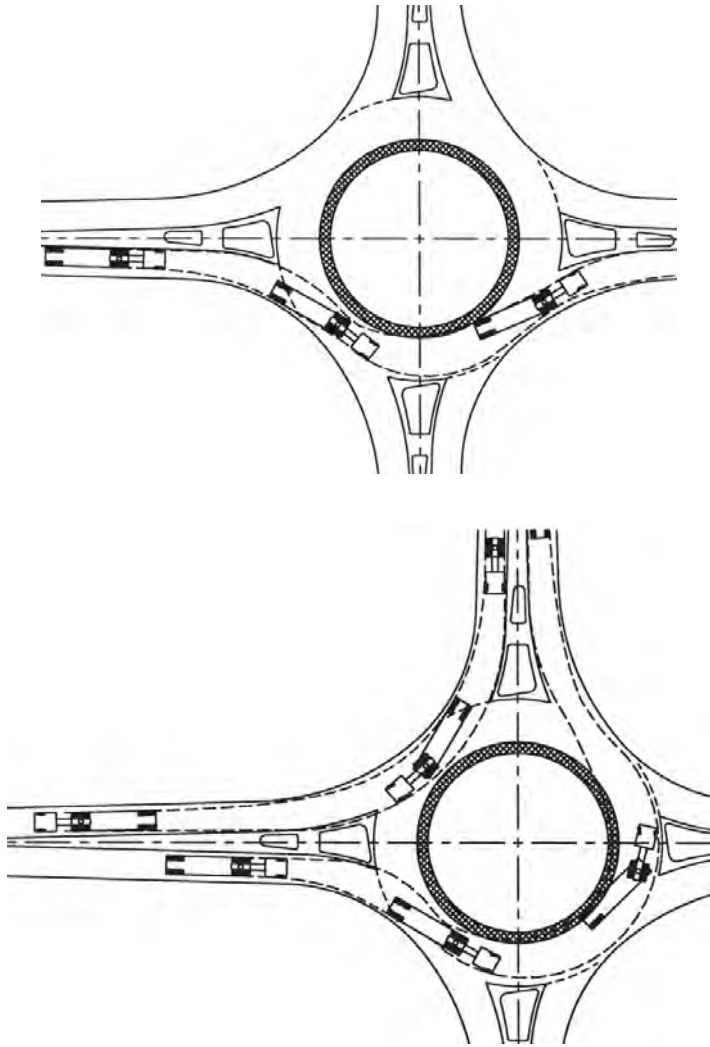

Exhibit 6-17
Through Movement Swept Path of WB-50 (WB-15) Vehicle

Exhibit 6-18
Turning Movement Swept Paths of WB-50 (WB-15) Vehicle

Larger-diameter roundabouts may be required to accommodate large vehicles while maintaining low speeds for passenger vehicles. However, in some cases, land constraints may limit the ability to accommodate large semi-trailer combinations while achieving adequate deflection for small vehicles. In such situations, a truck apron may be used to provide additional traversable area around the central island for large semi-trailers. Where provided, truck aprons should be designed with a curbed edge high enough to discourage passenger vehicles from traversing over the top of the apron. Additional discussion is provided in Section 6.8.7.

Passenger buses should be accommodated within the circulatory roadway without tracking over the truck apron, which could jostle bus occupants.

The location of the roundabout may dictate the use of specific design vehicles. Recreational routes are often frequented by motor homes and other recreational vehicles. Agricultural areas are frequented by tractors, combines, and other farm machinery. Manufacturing areas may see oversize trucks. Each of these special design vehicles should be incorporated very early into the design process since they can affect the fundamental design decisions of size, position, and alignment of approaches.

It may occasionally be appropriate to choose a smaller design vehicle for turning movements but a larger design vehicle for through movements. For example, in dense urban areas where right-of-way is at a premium, it may be reasonable to design so that single unit trucks and buses can easily make left turns, right turns, and through movements, but WB-50 vehicles and larger can only travel straight through the roundabout. For example, this design technique could be acceptable where large trucks travel along the major roadway but are prohibited from traveling along the cross street. This technique should be used with caution due to the fact that if applied inappropriately, it could result in trucks off-tracking into pedestrian areas, landscape areas, signs, or street furniture (see Exhibit 6-19).

Oversized vehicles are vehicles that typically require special permits due to their extreme weight and size. Engineers should inquire whether the route may potentially carry oversized vehicles and have to incorporate the needs of those vehicles in the design. Roundabouts should generally not be designed to provide normal circulation using an oversized truck as the design vehicle since this will result in excessive dimensions and higher speeds for the majority of users. Where oversized vehicles can be reasonably anticipated, the truck apron and central island design may need to be modified to accommodate the larger vehicles.

Exhibit 6-19
Vehicle Over-Tracking
from Inadequate Entry
and Exit Design



(a) Entry over-tracking



(b) Exit over-tracking

For locations with a high volume of truck traffic, special consideration may be given to the size of the roundabout to require use of the truck apron by only the largest of vehicles. For the example illustrated in Exhibit 6-20, the high volume of truck traffic traversing through the intersection dictated the use of a larger inscribed circle diameter. This larger diameter provides a greater ease of movement for large vehicles and minimizes the widths for the entries, exits, and circulatory roadway. While the design dimensions chosen for this roundabout were appropriate for the environmental context and design vehicle, the diameter of the roundabout should generally be kept to a minimum.



Florence, Kansas

Exhibit 6-20
Roundabout with High
Volume of Heavy Vehicles

6.4.7.1 Truck Aprons

A traversable truck apron is typical for most roundabouts to accommodate large vehicles while minimizing other roundabout dimensions. A truck apron provides additional paved area to allow the over-tracking of large semi-trailer vehicles on the central island without compromising the deflection for smaller vehicles. The width of the truck apron is defined based upon the swept path of the design vehicle. As described under Section 6.4.3, the circulatory roadway should typically be designed to accommodate a bus design vehicle. Therefore, any larger design vehicle would be expected to use the truck apron for accommodating the vehicle tracking.

Truck aprons should be designed such that they are traversable to trucks but discourage passenger vehicles from using them. Truck apron width is dictated by the tracking of the design vehicle using templates or CAD-based vehicle-turning-path simulation software. They should generally be 3 to 15 ft (1 to 4.6 m) wide and have a cross slope of 1% to 2% away from the central island. To discourage use by passenger vehicles, the outer edge of the apron should be raised approximately 2 to 3 in. (50 to 75 mm) above the circulatory roadway surface. The apron should be constructed of a different material than the pavement to differentiate it from the circulatory roadway. Care must be taken to ensure that delivery trucks will not experience load shifting as their rear trailer wheels track across the apron.

As illustrated in Exhibit 6-21, a wider truck apron is often required to accommodate a left-turning vehicle at a roundabout with a smaller inscribed circle diameter. This limits the amount of landscaping that can be provided, which may

Exhibit 6-21
Comparison of Swept Paths
for a WB-67 Design Vehicle
at Various Diameters



(a) Inscribed circle diameter of 125 ft (38 m)

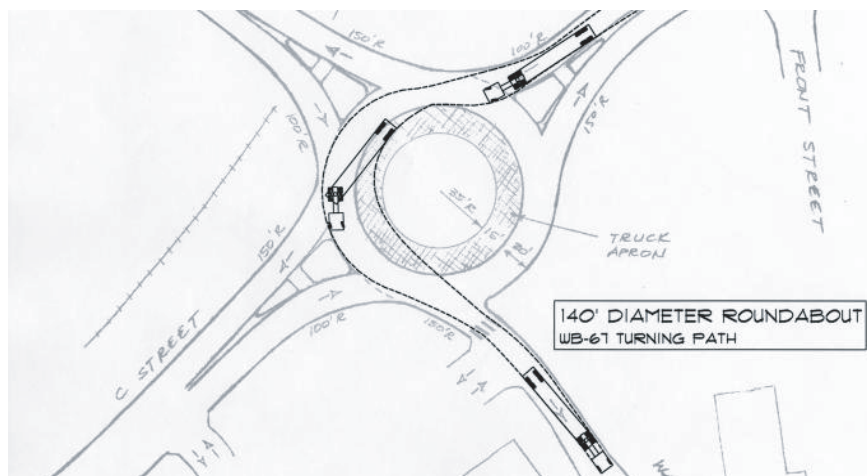

(b) Inscribed circle diameter of 140 ft (43 m)

in turn limit the visibility of the central island on the approach. Additionally, wider entries and larger entry radii are typically required for a small diameter roundabout to accommodate the design vehicle.

At single-lane roundabouts, the right-turn movement is often the controlling movement for the intersection. This is especially true for locations for skewed approach alignments (less than 90° angle between adjacent approach centerlines). To adequately accommodate the design vehicle, the corner radius (commonly a fillet between entry curve and adjacent exit curve) is frequently increased. This may result in a wide portion of circulatory roadway between the subject entrance and adjacent exit. This wide area is often striped out or an outside truck apron is provided. Both of these options are generally undesirable, although they may be considered under constrained situations. Alternative improvements to consider prior to implementing an outside truck apron include realigning the approaches to be more perpendicular, providing an offset-left alignment on the entry to improve the radius for truck turning, increasing the inscribed circle diameter, or providing a right-turn bypass.

Aesthetic features can be added to the truck apron that enhance the landscaping of the central island. The material used for the truck apron should be different than

the material used for the sidewalks so that pedestrians are not encouraged to cross the circulatory roadway. In addition, the truck apron features should be designed to encourage heavy vehicles to use this portion of the central island when necessary. If the colored or textured pavement appears to be for aesthetics only, truck drivers may be discouraged to traverse the apron (12). Exhibit 6-22 illustrates an example of applying aesthetic pavement treatments to the truck apron. Some agencies have used waffle block material as part of the truck apron, as shown in Exhibit 6-23. This provides additional truck apron width for the occasional large vehicle without adding additional impervious area.



(a) Arcata, California



(b) Santa Barbara, California

Exhibit 6-22
Example of Aesthetic Truck Apron Treatments



Killingworth, Connecticut

Exhibit 6-23
Example of Waffle Blocks Used within a Truck Apron

6.5 MULTILANE ROUNDABOUTS

The principles and design process described previously apply to multilane roundabouts but in a more complex way. Because multiple traffic streams may enter, circulate through, and exit the roundabout side-by-side, the engineer also should consider how these traffic streams interact with each other. The geometry of the roundabout should provide adequate alignment and establish appropriate lane configurations for vehicles in adjacent entry lanes to be able to negotiate the roundabout geometry without competing for the same space. Otherwise, operational and/or safety deficiencies may occur.

Multilane roundabout design tends to be less forgiving than single-lane roundabout design. Multilane design can have a direct impact on vehicle alignment and lane choice, which can affect both the safety performance and capacity. Capacity, safety, property impacts, and costs are interrelated, and a balance of these

components becomes more difficult with multilane roundabout design. Due to this balancing of design elements that is required to meet the design principles, the use or creation of boilerplate or standard designs is discouraged.

The design of pavement markings and signs at a multilane roundabout is also critical to achieving predicted capacities and optimal overall operations. Geometry, pavement markings, and signs must be designed together to create a comprehensive system to guide and regulate road users who are traversing roundabouts. The marking plan should be integral to the preliminary design phase of a project. Chapter 7 provides additional detail on the design of pavement markings and signs for multilane roundabouts.

In addition to the fundamental principles outlined in Section 6.2, other key considerations for all multilane roundabouts include:

- Lane arrangements to allow drivers to select the appropriate lane on entry and navigate through the roundabout without changing lanes,
- Alignment of vehicles at the entrance line into the correct lane within the circulatory roadway,
- Accommodation of side-by-side vehicles through the roundabout (i.e., a truck or bus traveling adjacent to a passenger car),
- Alignment of the legs to prevent exiting–circulating conflicts, and
- Accommodation for all travel modes.

The reader should also refer to Section 6.4 on single-lane roundabouts as some design elements [such as central islands (Section 6.4.4)] are not described again in this multilane roundabouts section because the information is not substantially different for multilane design. Section 6.8 also provides additional information pertaining to design of pedestrian and bicycle facilities.

6.5.1 LANE NUMBERS AND ARRANGEMENTS

Multilane roundabouts have at least one approach with at least two lanes on the entries or exits. The number of lanes can vary from approach to approach as long as they are appropriately assigned by lane designation signs and markings. Likewise, the number of lanes within the circulatory roadway may vary depending upon the number of entering and exiting lanes. The important principle is that the design requires continuity between the entering, circulating, and exiting lanes such that lane changes are not needed to navigate the roundabout. The driver should be able to select the appropriate lane upstream of the entry and stay within that lane through the roundabout to the intended exit without any lane changes. This principle is consistent with the design of all types of intersections.

The number of lanes provided at the roundabout should be the minimum needed for the existing and anticipated demand as determined by the operational analysis. The engineer is discouraged from providing additional lanes that are not needed for capacity purposes as these additional lanes can reduce the safety effectiveness at the intersection. If additional lanes are needed for future conditions, a phased design approach should be considered that would allow for future expansion.

On multilane roundabouts, it is also desirable to achieve balanced lane utilization in order to be able to achieve predicted capacity. There are a number of design variables that can produce lane imbalance, such as poorly designed entry or exit alignments or turning movement patterns. There is also a need to recognize possible downstream system variables, such as a major trip generator, interchange ramp, or bottleneck at a downstream intersection. All of these variables may influence lane choice at a roundabout.

6.5.2 ENTRY WIDTH

The required entry width for any given design is dependent upon the number of lanes and design vehicle. A typical entry width for a two-lane entry ranges from 24 to 30 ft (7.3 to 9.1 m) for a two-lane entry and from 36 to 45 ft (11.0 to 13.7 m) for a three-lane entry. Typical widths for individual lanes at entry range from 12 to 15 ft (3.7 to 4.6 m). The entry width should be primarily determined based upon the number of lanes identified in the operational analysis combined with the turning requirements for the design vehicle. Excessive entry width may not produce capacity benefits if the entry width cannot be fully used by traffic.

For locations where additional entry capacity is required, there are generally two options:

1. Adding a full lane upstream of the roundabout and maintaining parallel lanes through the entry geometry; or
2. Widening the approach gradually (flaring) through the entry geometry.

Exhibit 6-24 and Exhibit 6-25 illustrate these two widening options.

Approach flaring may provide an effective means of increasing capacity without requiring as much right-of-way as a full lane addition. In addition, U.K. research suggests that length of flare affects capacity without a direct effect on safety. Although this research has not been replicated in the United States, the U.K. findings suggest that the crash frequency for two approaches with the same entry width will be identical whether they have parallel entry lanes or flared entry

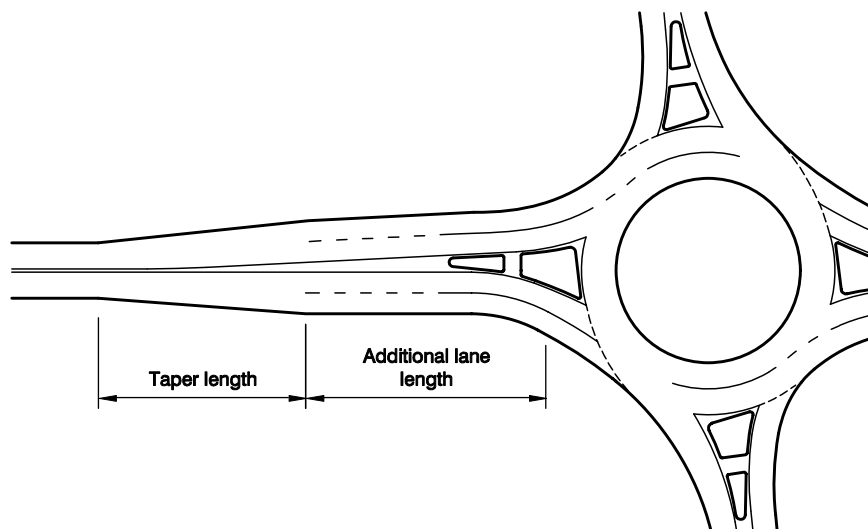
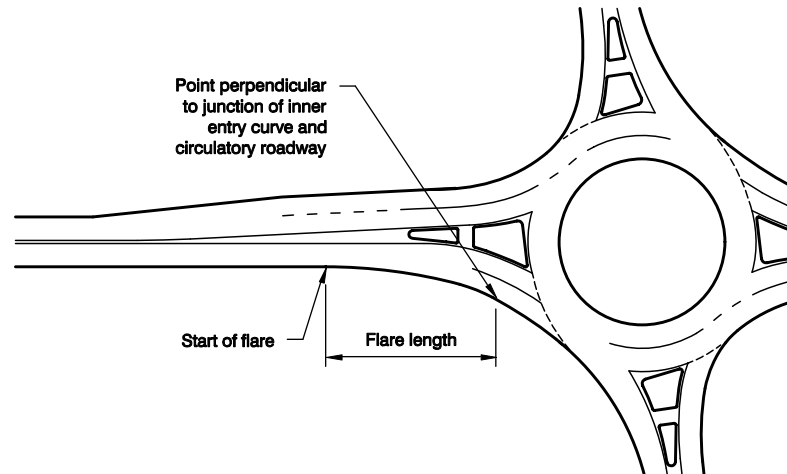

Exhibit 6-24
Approach Widening by Adding
a Full Lane

Exhibit 6-25
Approach Widening
by Entry Flaring



designs. Entry widths should therefore be minimized and flare lengths maximized to achieve the desired capacity with minimal effect on crashes.

6.5.3 CIRCULATORY ROADWAY WIDTHS

The circulatory roadway width is usually governed by the design criteria relating to the types of vehicles that may need to be accommodated adjacent to one another through a multilane roundabout. The provision of pavement markings within the circulatory roadway (discussed in Chapter 7) may require extra space and the use of a truck apron to support lane discipline for trucks and cars circulating. The combination of vehicle types to be accommodated side-by-side is dependent upon the specific site traffic conditions, and requirements for side-by-side design vehicles may vary by individual state or local jurisdiction. Further research on this topic is underway at the time of this publication, and the reader is advised to look to the latest guidance for the conditions being explored.

If the entering traffic is predominantly passenger cars and single-unit trucks (AASHTO P and SU design vehicles, respectively), where semi-trailer traffic is infrequent, it may be appropriate to design the width for two passenger vehicles or a passenger car and a single-unit truck side-by-side. If semi-trailer traffic is relatively frequent (greater than 10%), it may be necessary to provide sufficient width for the simultaneous passage of a semi-trailer in combination with a P or SU vehicle.

Multilane circulatory roadway lane widths typically range from 14 to 16 ft (4.3 to 4.9 m). Use of these values results in a total circulating width of 28 to 32 ft (8.5 to 9.8 m) for a two-lane circulatory roadway and 42 to 48 ft (12.8 to 14.6 m) total width for a three-lane circulatory roadway.

At multilane roundabouts, the circulatory roadway width may also be variable depending upon the number of lanes and the design vehicle turning requirements. A constant width is not required throughout the entire circulatory roadway, and it is desirable to provide only the minimum width necessary to serve the required lane configurations within that specific portion of the roundabout. A common combination is two entering and exiting lanes along the major roadway, but only single entering and exiting lanes on the minor street. This combination is illustrated in Exhibit 6-26. In this example, the portion of circulatory roadway that serves the

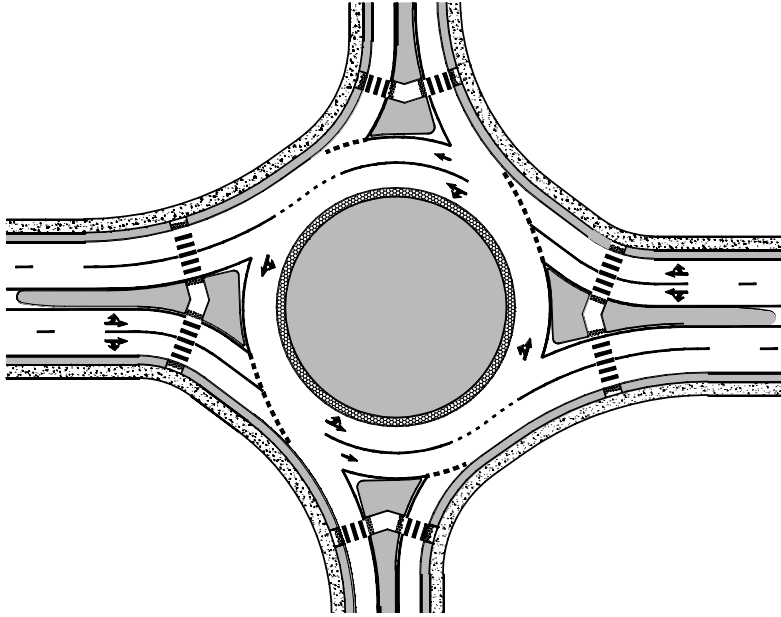

Exhibit 6-26
Multilane Major Street with
Single Lane on Minor Street

minor street has been reduced to a single lane to provide consistency in the lane configurations. For the portions of a multilane roundabout where the circulatory roadway is reduced to a single lane, the guidance for circulatory roadway width contained in Section 6.4.3 should be used.

In some instances, the circulatory roadway width may actually need to be wider than the corresponding entrance that is feeding that portion of the roundabout. For example, in situations where two consecutive entries require exclusive left turns, a portion of the circulatory roadway will need to contain an extra lane and spiral markings to enable all vehicles to reach their intended exits without being trapped or changing lanes. This situation is illustrated in Exhibit 6-27,

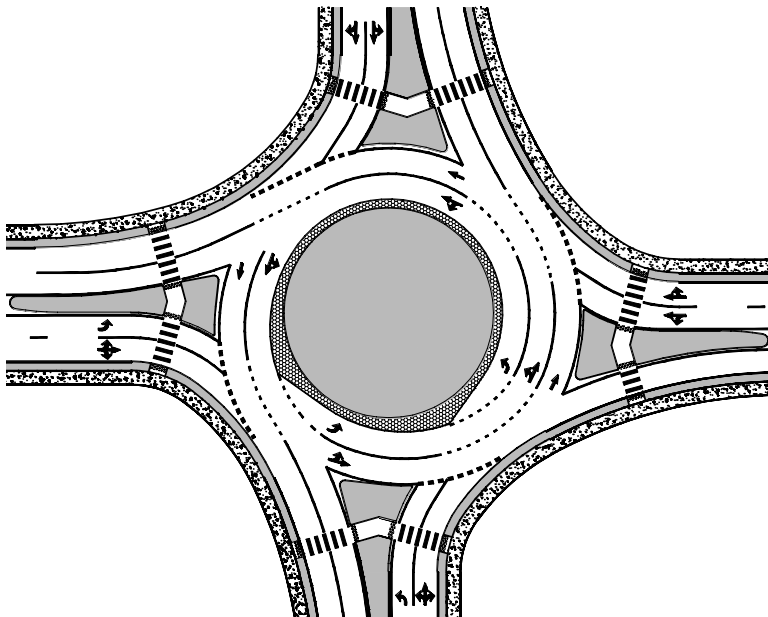

Exhibit 6-27
Two-Lane Roundabout with
Consecutive Double-Lefts

where a portion of the circulatory roadway is required to have three lanes despite the fact that all of the entries have only two lanes.

6.5.4 ENTRY GEOMETRY AND APPROACH ALIGNMENT

At multilane roundabouts, the design of the entry curvature should balance the competing objectives of speed control, adequate alignment of the natural paths, and the need for appropriate visibility lines. This often requires several iterations of design to identify the appropriate roundabout size, location, and approach alignments.

Individual geometric parameters also play a role in the balanced entry design. For example, entry radii are one key parameter that is often used to control vehicle speeds. The use of small entry radii may produce low entry speeds but often leads to path overlap on the entry since vehicles will cut across lanes to avoid running into the central island. Small entry radii may also result in an increase in single-vehicle crashes onto the central island.

Entry radii for multilane roundabouts should typically exceed 65 ft (20 m) to encourage adequate natural paths and avoid sideswipe collisions on entry. Engineers should avoid the use of overly tight geometrics in order to achieve the fastest-path objectives. Overly small [less than 45 ft (13.7 m)] entry radii can result in conflicts between adjacent traffic streams, which may result in poor lane use and reduced capacity. Similarly, the R_1 fastest-path radius should also not be excessively small. If R_1 is too small, vehicle path overlap may result, reducing the operational efficiency and increasing potential for crashes. Values for R_1 in the range of 175 to 275 ft (53 to 84 m) are generally preferable. This results in a design speed of 25 to 30 mph (40 to 50 km/h).

Vehicle path overlap is a type of conflict that occurs when the natural path of the adjacent lanes cross one another. It occurs most commonly at entries, where the geometry of the right (outside) lane tends to lead vehicles into the left (inside) circulatory lane. However, vehicle path overlap can also occur at exits where the geometry tends to lead vehicles from the left-hand lane into the right-hand exit lane. Exhibit 6-28 illustrates an example of entry vehicle path overlap.

Increasing vehicle path curvature decreases relative speeds between entering and circulating vehicles but also increases side friction between adjacent traffic streams in multilane roundabouts.

Exhibit 6-28
Entry Vehicle Path Overlap

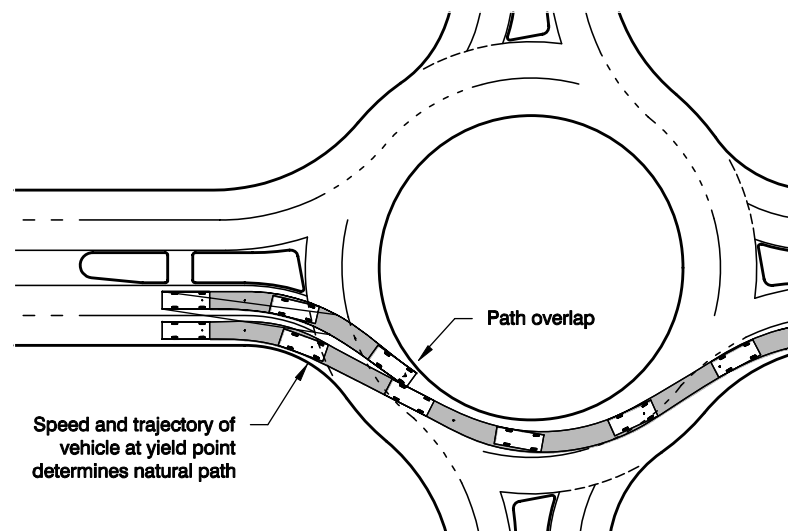

The engineer should balance the need to control entry speed with the need to provide good path alignment at multilane entries. The desired result of the entry design is for vehicles to naturally be aligned into their correct lane within the circulatory roadway, as illustrated in Exhibit 6-29. This can be done a variety of ways that can vary significantly depending on site-specific conditions. Therefore, it may not be possible to specify a single method for designing multilane roundabouts since this can preclude the needed flexibility in design. Regardless of the specific design technique employed, the engineer should maintain the overall design principles of speed management presented in Section 6.2.

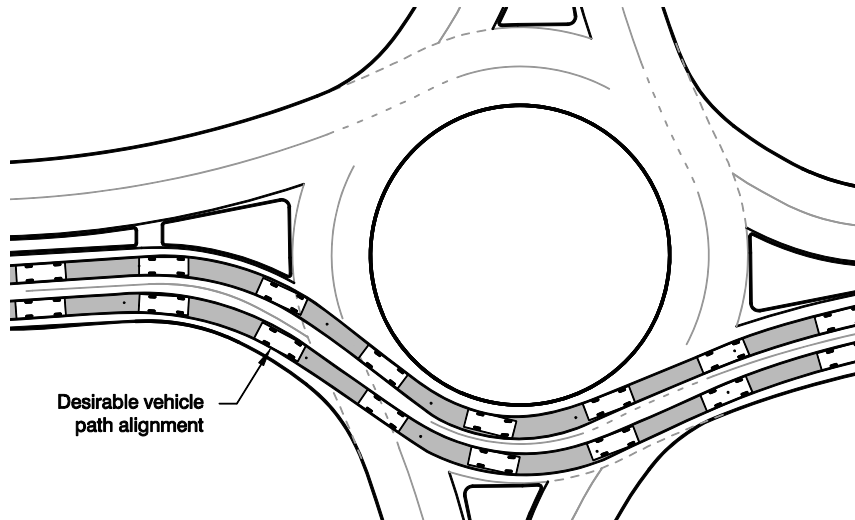

Exhibit 6-29
Desirable Vehicle Path Alignment

One possible technique to promote good path alignment is shown in Exhibit 6-30 using a compound curve or tangent along the outside curb. The design consists of an initial small-radius entry curve set back from the edge of the circulatory roadway. A short section of a large-radius curve or tangent is provided between the entry curve and the circulatory roadway to align vehicles into the proper circulatory lane at the entrance line. Care should be taken in determining the optimal location

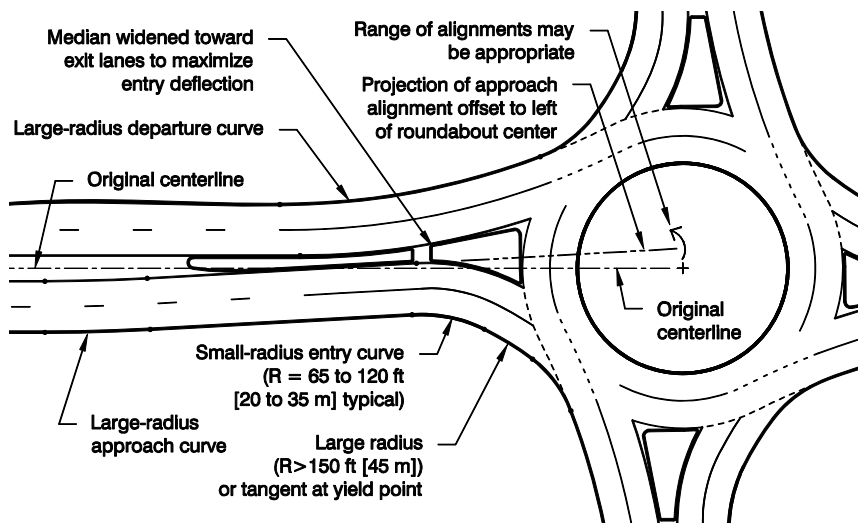

Exhibit 6-30
Example Minor Approach Offset to Increase Entry Deflection

of the entry curve from the entrance line. If it is located too close to the circulatory roadway, the tangent (or large radius portion of the compound curve) will be too short, and the design may still have path alignment issues. However, if the entry curve is located too far away from the circulatory roadway, it can result in inadequate deflection (i.e., entry speeds too fast).

For the method illustrated in Exhibit 6-30, entry curve radii commonly range from approximately 65 to 120 ft (20 to 35 m) and are set back at least 20 ft (6 m) from the edge of the circulatory roadway. A tangent or large-radius [greater than 150 ft (45 m)] curve is then fitted between the entry curve and the outside edge of the circulatory roadway.

An alternative method for designing the entry curves to a multilane roundabout is to use a single-radius entry curve rather than a small curve and tangent. This is similar in some regards to a single-lane design; however, larger radii are typically required to provide adequate vehicle alignment. Care must be taken when using a single entry curve to meet both the speed control and vehicle natural path alignment objectives. If the circulatory roadway is sufficiently wide relative to the entry, entry curves can be designed tangential to a design circle offset 5 ft (1.5 m) from the central island rather than to the central island. This improves the curvature and deflection that is achieved on the inside (splitter island) edge of the entry. Regardless of the method used, it is desirable for the inside (splitter island) curb to block the through path of the left lane to promote adequate deflection.

Another key factor in multilane roundabout design is to recognize that achieving adequate deflection on entry and meeting the principles is independent of the centerline of the approaching roadways. As discussed in Section 6.3, the centerlines of approach roadways do not need to pass through the center of the inscribed circle. It is acceptable design practice for multilane roundabouts to have an offset-left alignment, and in many cases this may provide a useful tool for achieving additional deflection and speed control.

Exhibit 6-31 illustrates an example of a design technique to enhance the entry deflection by shifting the approach alignment further toward the left of the roundabout center. This technique of offsetting the approach alignment left of the roundabout center is effective at increasing entry deflection. However, it also reduces the deflection of the exit on the same leg, where it is desirable to keep speeds relatively low within the pedestrian crosswalk location. Therefore, the distance of the approach offset from the roundabout center should be balanced with the other design objectives to maximize safety for pedestrians. Exhibit 6-32 illustrates an example of this technique being applied for a partial three-lane roundabout.

Other important components of the design of an entry are sight distance and visibility, as discussed in Section 6.2.6. The angle of visibility to the left must be adequate for entering drivers to comfortably view oncoming traffic from the immediate upstream entry or from the circulatory roadway. This requires that the vehicles be staggered at the entrance line such that vehicles nearest to the outside curb can see in front of the vehicle in the adjacent lane to the left of them. The design of the entry must balance the design objective of providing speed control with providing appropriate angles of visibility for drivers. Additional details on measuring angles of visibility are provided in Section 6.7.4.



Source: Wisconsin Department of Transportation (7)

Exhibit 6-31
Example of Major Approach
Offset to Increase Entry
Deflection

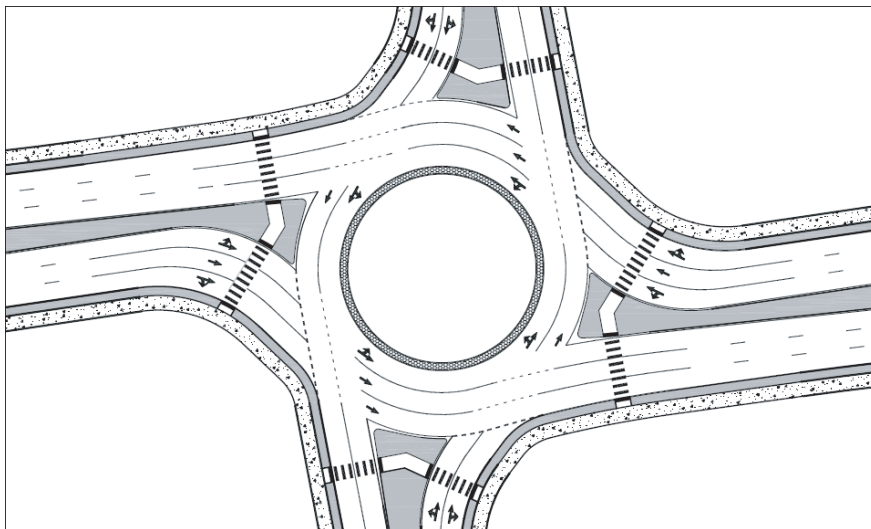

Exhibit 6-32
Example of a Partial Three
Lane Roundabout with an
Offset Approach Alignment

As discussed previously for single-lane roundabouts, a useful surrogate for capturing the effects of entry speed, path alignment, and visibility to the left is entry angle (ϕ). Typical entry angles are between 20° and 40° . Additional detail on entry angle can be found in the Wisconsin Department of Transportation *Roundabout Guide* (7) and design guidance from the United Kingdom (9, 10).

6.5.5 SPLITTER ISLANDS

For multilane roundabouts, the entry geometry is typically established first to identify a design that adequately controls fastest-path entry speeds, avoids entry path overlap, and accommodates the design vehicle. The splitter island is then developed in conjunction with the exit design to provide an adequate median width for the pedestrian refuge and for sign placement. Adequate median width should be provided to accommodate necessary equipment and pedestrian design elements where signalized pedestrian crossings are used. Additional details

regarding the minimum dimensions and design details for splitter islands are provided under the discussion of single-lane roundabouts in Section 6.4.1. Additional discussion of pedestrian crosswalk design is provided in Section 6.8.1 and considerations for signalized pedestrian crossing are discussed in Chapter 7.

6.5.6 EXIT CURVES

As with the entries, the design of the exit curvature at multilane roundabouts is more complex than at single-lane roundabouts. Conflicts can occur between exiting and circulating vehicles if appropriate lane assignments are not provided. Inadequate horizontal design of the exits can also result in exit vehicle path overlap, similar to that occurring at entries. The radii of exit curves are commonly larger than those used at the entry as a consequence of other factors (entry alignment, diameter, etc.); larger exit curve radii are also typically used to promote good vehicle path alignment. However, the design should be balanced to maintain low speeds at the pedestrian crossing at the exit.

To promote good path alignment at the exit, the exit radius at a multilane roundabout should not be too small. At single-lane roundabouts, it is acceptable to use a minimal exit radius in order to control exit speeds and maximize pedestrian safety. However, if the exit radius on a multilane exit is too small, traffic on the inside of the circulatory roadway will tend to exit into the outside exit lane on a more comfortable turning radius.

Problems can also occur when the design allows for too much separation between entries and subsequent exits. Large separations between legs causes entering vehicles to join next to circulating traffic that may be intending to exit at the next leg, rather than crossing the path of the exiting vehicles. This can create conflicts at the exit point between exiting and circulating vehicles, as shown in Exhibit 6-33.

Exhibit 6-33
Exit-Circulating Conflict
Caused by Large Separation
between Legs

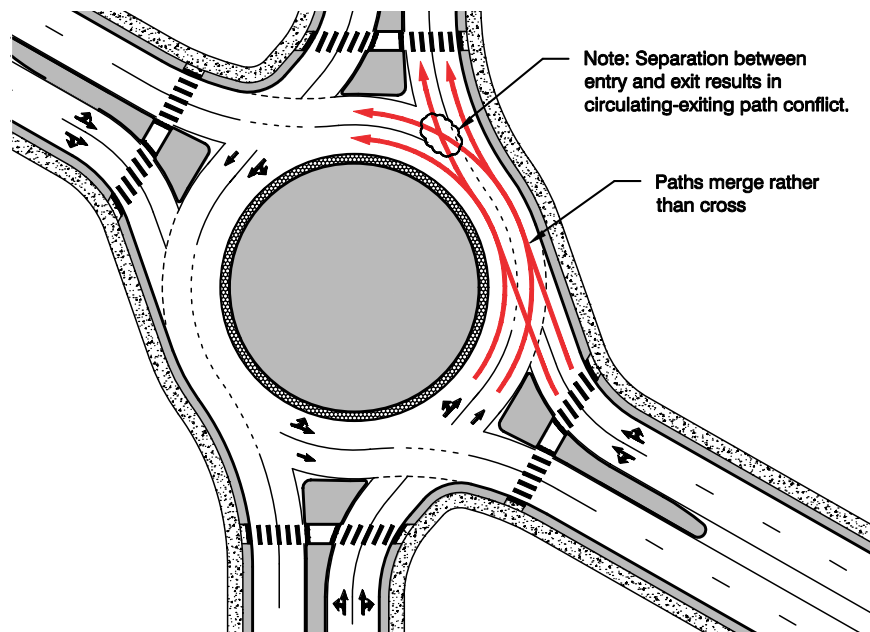

Source: California Department of Transportation (1)

Exhibit 6-34 illustrates a possible low-cost fix that involves modifications to the lane arrangements using a combination of striping and physical modifications. This may be acceptable if the traffic volumes are compatible. A better solution is illustrated in Exhibit 6-35, which involves realignment of the approach legs to have the paths of entering vehicles cross the paths of the circulating traffic (rather than merging) to eliminate the conflict.

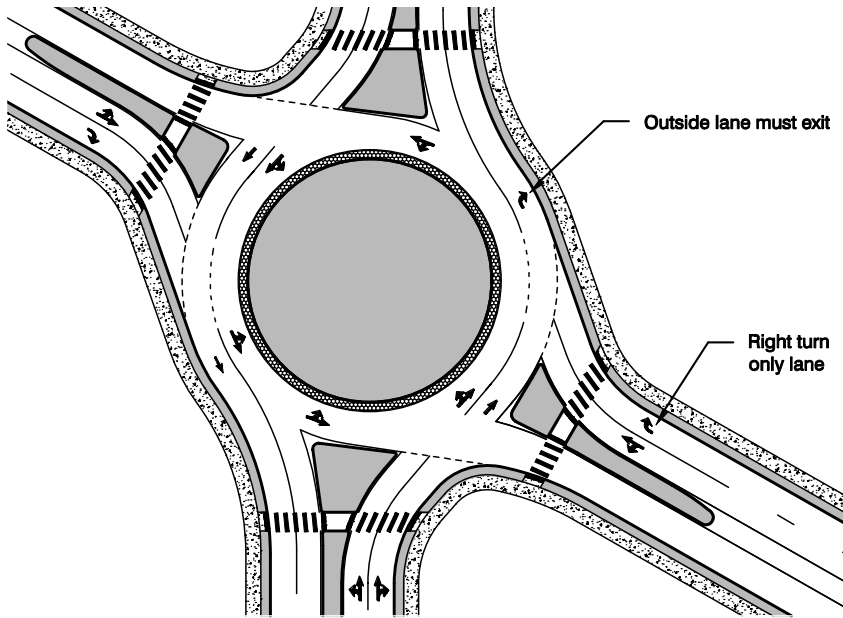

Exhibit 6-34
Possible Lane Configuration
Modifications to Resolve
Exit-Circulating Conflicts

Source: California Department of Transportation (1)

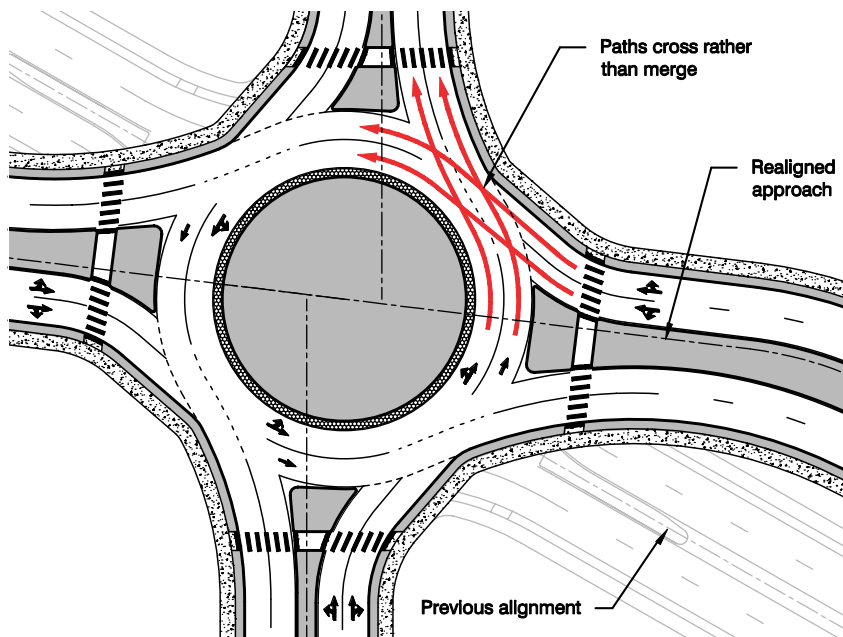

Exhibit 6-35
Realignment to Resolve
Exit-Circulating Conflicts

Source: California Department of Transportation (1)

6.5.7 DESIGN VEHICLE CONSIDERATIONS

Design vehicle considerations should be made for both tracking on the entry/exit and within the circulatory roadway (as previously discussed in Section 6.5.3). The percentage of trucks and lane utilization is an important consideration when determining whether the design will allow trucks to use two lanes or accommodate them to stay within their own lane. The frequency of a particular design vehicle is also an important consideration. For instance, a particular roundabout may have infrequent use by WB-67-size tractor-trailers and is thus designed to allow the WB-67 to claim both lanes to navigate through. However, the same location could have frequent bus service that would dictate the need to accommodate buses within their own lane to travel adjacent to a passenger car (see Exhibit 6-36). Therefore, a particular roundabout may have multiple design vehicles depending upon the unique site characteristics.

Exhibit 6-36
Side-by-Side Navigation for a
Bus and Passenger Car

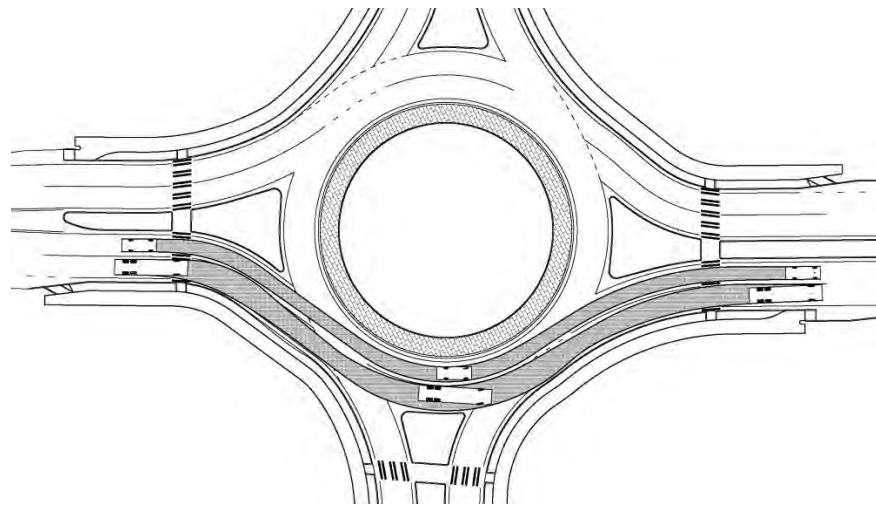

Where the design dictates the need to accommodate large design vehicles within their own lane, there are a number of design considerations that come into play. A larger inscribed circle diameter and entry/exit radii may be required to maintain speed control and accommodate the design vehicle. A technique that has been used in the United States on the entry is to provide gore striping—a striped vane island between the entry lanes—to help center the vehicles within the lane and allow a cushion for off-tracking by the design vehicle. This technique is illustrated in Exhibit 6-37. The actual dimensions used may vary depending on the individual design; however, one state (11) identified the use of two 12 ft (3.6 m) lanes and a 6 ft (1.8 m) wide gore area for an entrance with a total width of 30 ft (9 m).

Another technique for accommodating the design vehicle within the circulatory roadway is to use a wider lane width for the outside lane and a narrower lane width for the inside lane. For example, for a 32 ft (9.8 m) circulatory roadway width, an inside width of 15 ft (4.6 m) and an outside width of 17 ft (5.2 m) could be used. This would provide an extra two feet of circulating width for trucks in the outside lane. Large trucks in the inside lane would use the truck apron to accommodate any off tracking. Eliminating all overlap for the outside lane may not always be desirable or feasible, as this may dictate a much larger inscribed circle diameter than desired for overall safety performance for all vehicle types and the context.

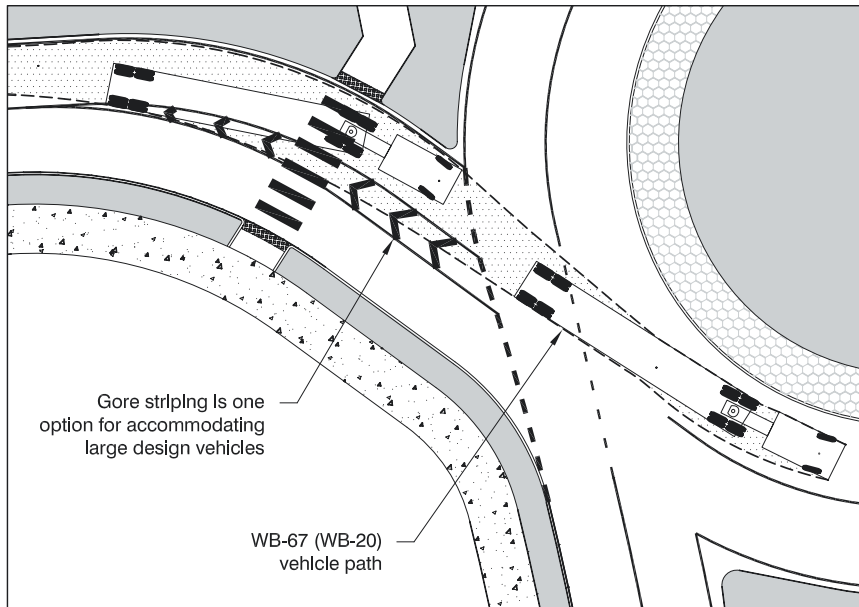

Source: New York State Department of Transportation (11)

Exhibit 6-37
WB-67 (WB-20) Truck Path
with Gore Striping at Entry

6.5.8 OTHER DESIGN PRACTICES

Throughout the world there continues to be advancement in the design practices for multilane roundabouts. One practice initiated in the Netherlands and being tested elsewhere is the turbo-roundabout (13). This style of multilane design has two key features that distinguish it from other multilane roundabouts:

- Entries are perpendicular to the circulatory roadway, and
- Raised lane dividers are used within the circulatory roadway to guide drivers to the appropriate exit.

This treatment has not been used in the United States at the time of this writing.

6.6 MINI-ROUNDAOBOUTS

A mini-roundabout is an intersection design form that can be used in place of stop control or signalization at physically constrained intersections to help improve safety and reduce delays. Typically characterized by a small diameter and traversable islands, mini-roundabouts are best suited to environments where speeds are already low and environmental constraints would preclude the use of a larger roundabout with a raised central island. Exhibit 6-38 presents the characteristics of a mini-roundabout.

Mini-roundabouts operate in the same manner as larger roundabouts, with yield control on all entries and counterclockwise circulation around a central island. Due to the small footprint, large vehicles are typically required to travel over the fully traversable central island, as shown in Exhibit 6-38. To help promote safe operations, the design generally aligns passenger cars in such a way as

Exhibit 6-38
Basic Characteristics of
a Mini-Roundabout

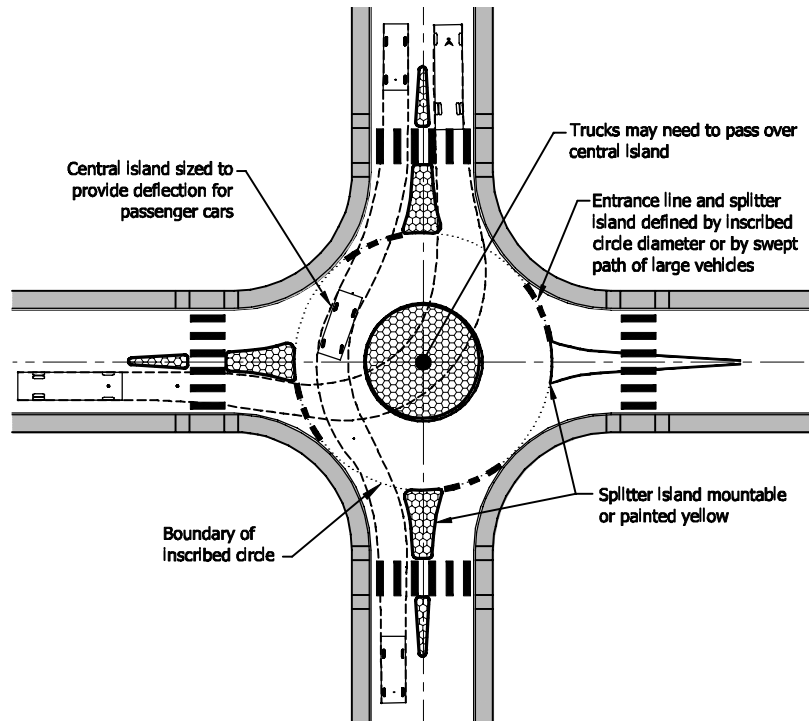

to naturally follow the circulatory roadway and minimize running over of the central island to the extent possible.

6.6.1 GENERAL DESIGN CRITERIA FOR MINI-ROUNDBABOUTS

Many of the same principles are used in the design of mini-roundabouts as in full-sized roundabouts. Key considerations include vehicle channelization, design vehicle paths, and intersection visibility. Given that the central island of a mini-roundabout is fully traversable, the overall design should provide channelization that naturally guides drivers to the intended path. Sub-optimum designs may result in drivers turning left in front of the central island (or driving over the top of it), improperly yielding, or traveling at excess speeds through the intersection.

A mini-roundabout is often considered as an alternative to a larger single-lane roundabout due to a desire to minimize impacts outside of the existing intersection footprint. Therefore, the existing intersection curb lines are a typical starting point for establishing the mini-roundabout inscribed circle diameter. Mini-roundabouts should be made as large as possible within the intersection constraints. However, a mini-roundabout inscribed circle diameter should generally not exceed 90 ft (30 m). Above 90 ft (30 m), the inscribed circle diameter is typically large enough to accommodate the design vehicles navigating around a raised central island. A raised central island provides physical channelization to control vehicle speeds, and therefore a single-lane design is preferred where a diameter greater than 90 ft (30 m) can be provided.

The fully traversable central island provides the clearest indication to the user that the intersection is a mini-roundabout. The location and size of a mini-roundabout's central island (and the corresponding width of the circulatory roadway) is dictated primarily by passenger car swept path requirements. The island

location should be at the center of the of the left-turning inner swept paths, which will be near, but not necessarily on, the center of the inscribed circle (14). The off-tracking of a large design vehicle should be accommodated by the footprint of the central island; meanwhile, passenger cars should be able to navigate through the intersection without being required to travel over the central island. As with single-lane and multilane roundabouts, it is desirable to also accommodate buses within the circulatory roadway to avoid jostling passengers by running over a traversable central island. However, for very small inscribed circle diameters, the bus turning radius is typically too large to navigate around the central island, thus requiring buses to travel over it. For mini-roundabouts with larger inscribed circle diameters, it may be possible to accommodate the swept path of a bus vehicle within the circulatory roadway. The potential trade-off to designing for a bus instead of a passenger car is that the design may result in a wider circulatory roadway and smaller central island.

The location of the central island should allow for all movements to be accommodated at the intersection with counterclockwise circulation. Designing the central island size and location to provide deflection through the roundabout will encourage proper circulation and reduced speeds through the intersection.

The central island is typically fully traversable and may either be domed or raised with a mountable curb and flat top for larger islands. Although painted central islands are commonly used in the UK, flush central islands are discouraged in other countries to maximize driver compliance. Composed of asphalt concrete, Portland cement concrete, or other paving material, the central island should be domed using 5% to 6% cross slope, with a maximum height of 5 in. (15). Although fully traversable and relatively small, it is essential that the central island be clear and conspicuous (15–16). Islands with a mountable curb should be designed in a similar manner to truck aprons on normal roundabouts.

The central island should be either delineated with a solid yellow line or completely covered with a yellow color. A yellow marking color is required by the MUTCD to provide consistency with other markings used where traffic typically travels to the right of the marking. If the entire center island is colored yellow, an anti-skid surface is recommended to increase surface friction and avoid slick surfaces, particularly for bicycles and motorcycles. A textured surface that provides a visible differentiation from the circulatory roadway may also be used, accompanied by a solid yellow line. In the United Kingdom, the center island must be marked in a solid white color to provide a uniform appearance and make the island conspicuous (17).

As described in Chapter 7, the edge line extension across the approach lane of roundabouts also serves as the entrance line. Two common options are used for placement of this line. One option is to place the entrance line at the outer edge of the inscribed circle diameter, common with the practice for single-lane and multi-lane roundabouts. Another option is to advance the entrance line toward the central island such that it is no longer coincident with the inscribed circle of the roundabout. The outer swept path of passenger cars and the largest vehicle likely to use the intersection is identified for all turning movements, and the advanced entrance line is placed at least 2 ft (0.6 m) outside of the vehicle paths. Skewed approaches are one particular situation where advancing the yield line may be

The central island of a mini-roundabout should be clear and conspicuous.

beneficial to discourage vehicles from making a left turn in front of the central island. However, this may result in a reduction of capacity since advancing the yield line may affect yielding behavior at the entry.

Exhibit 6-39 illustrates one particular situation where the design allows passenger cars to turn left in front of the central island. In this case, the combination of the intersection skew angle, small size of the central island, small size of the splitter islands, and large width of the circulatory roadway makes it comfortable for a driver to turn left in front of the central island instead of navigating around it. Three possible design improvements are illustrated in Exhibit 6-40. These include (1) advancing the yield line forward, (2) simultaneously enlarging the central island and reducing the circulatory roadway width, and (3) enlarging the inscribed circle diameter.

Exhibit 6-39
Design That Allows Left Turns
in Front of Central Island

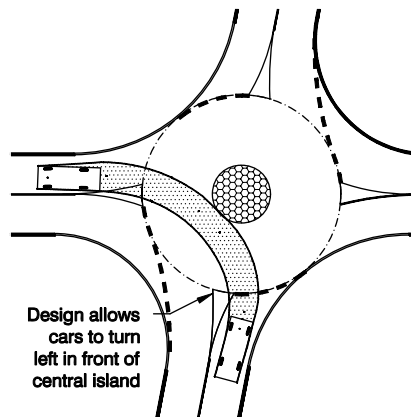
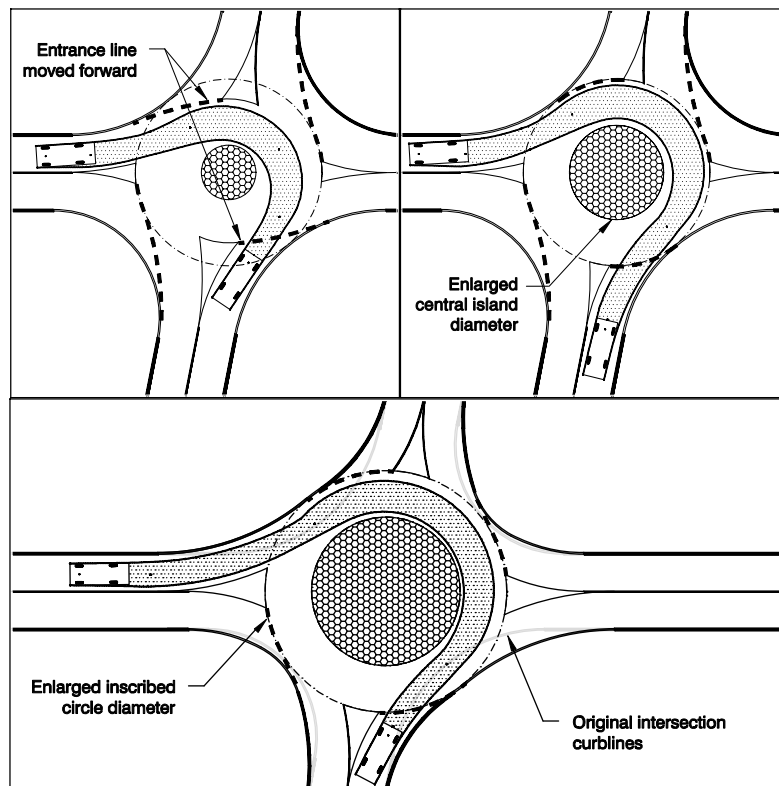

Exhibit 6-40
Possible Design Improvements to Resolve Turning in Front of Mini-Roundabout Central Island



For intersections with excessive skew or offset approach alignments, the use of dual mini-roundabouts is another option for providing adequate vehicle channelization through the intersection (14–15, 17–18). Under this scenario, the intersection is divided into two adjacent mini-roundabouts. The design accommodates proper circulation for light vehicles (such as passenger cars) and traversable islands to allow for navigation of large vehicles through the intersection. Although this type of design has been implemented in the United Kingdom, it is rare elsewhere.

6.6.1.1 Splitter Islands

As with larger roundabouts, splitter islands are generally used at mini-roundabouts to align vehicles, encourage deflection and proper circulation, and provide pedestrian refuge. Splitter islands are raised, traversable, or flush depending on the size of the island and whether trucks will need to track over the top of the splitter island to navigate the intersection. In general, raised islands are used where possible, and flush islands are generally discouraged. The following are general guidelines for the types of splitter islands under various site conditions:

- Consider a raised island if:
 - All design vehicles can navigate the roundabout without tracking over the splitter island area,
 - Sufficient space is available to provide an island with a minimum area of 50 ft² (4.6 m²), and/or
 - Pedestrians are present at the intersection with regular frequency.
- Consider a traversable island if:
 - Some design vehicles must travel over the splitter island area and truck volumes are minor, and
 - Sufficient space is available to provide an island with a minimum area of 50 ft² (4.6 m²).
- Consider a flush (painted) island if:
 - Vehicles are expected to travel over the splitter island area with relative frequency to navigate the intersection,
 - An island with a minimum area of 50 ft² (4.6 m²) cannot be achieved, and
 - Intersection has slow vehicle speeds.

Where entrance lines are located within the inscribed circle, raised splitter islands typically terminate at the edge of the inscribed circle rather than being carried to the entrance line location. This allows sufficient space within the circulatory roadway for U-turn movements to occur. A painted or traversable splitter island should be continued to the entrance line to guide entering motorists around the central island.

In some cases, sufficient space may be available to provide a partial raised island within the pedestrian refuge area. An example of a raised island being terminated prior to the entrance line is illustrated in Exhibit 6-41. If raised islands are used, they should be visible to approaching motorists.

Exhibit 6-41
Raised Splitter Island
Terminated in Advance
of the Entrance Line



Dimondale, Michigan

6.6.1.2 Pedestrian Treatments at Mini-Roundabouts

At conventional intersections, pedestrian ramps and crosswalks are typically located near the curb returns at the corners of the intersection. When converting to a mini-roundabout, these corner pedestrian-crossing locations may require relocation. The crosswalk is recommended to be located 20 ft (6 m) upstream of the entrance line to accommodate one vehicle stopped between the crosswalk and the entrance line.

Where a traversable or raised splitter island is used, the walkway through the splitter island should be cut through instead of ramped. This is less cumbersome for wheelchair users and allows the cut-through walkway to be aligned with the crosswalks, providing guidance for all pedestrians but particularly for those who are blind or who have low vision. The cut-through walkway should be approximately the same width as the crosswalk, ideally a minimum width of 10 ft (3 m).

Sidewalk ramps must be provided to connect to the sidewalks at each end of the crosswalk. Wherever sidewalks are set back from the roundabout with a planting strip, ramps do not need to have flares and should simply have curbed edges aligned with the crosswalk to provide alignment cues for pedestrians who are blind or who have low vision. A detectable warning surface consisting of raised truncated domes is applied to the ramps to meet accessibility requirements.

Where a minimum splitter island width of 6 ft (1.8 m) is available on the approach, a pedestrian refuge should be provided within the splitter island. Where a pedestrian refuge is provided, the refuge area must be defined with the use of detectable warning surfaces. The detectable warning surface on splitter islands should begin at the curb line and extend into the cut-through area a distance of 2 ft (0.6 m), leaving a clear space of at least 2 ft (0.6 m) between detectable warning surfaces. Detailed standards for detectable warning surfaces can be found in the accessibility guidelines provided by the U.S. Access Board.

In some cases, the available roadway width may not be sufficient to provide an adequate refuge area, in which case pedestrians will need to cross in one stage. In such cases, no detectable warnings should be used within the splitter island.

6.6.1.3 Bicycles at Mini-Roundabouts

Since typical on-road bicycle travel speeds are between 12 and 20 mph (20 to 30 km/h), the speeds of vehicles approaching and traveling through mini-roundabouts are similar to those of bicyclists. Bicyclists are encouraged to navigate through a mini-roundabout like other vehicles. Where bicycle lanes are provided on the approaches to a mini-roundabout, they should be terminated to alert motorists and bicyclists of the need for bicyclists to merge. Bike lanes should be terminated at least 100 ft (30 m) upstream of the entrance line. Additional information on bicycle design considerations can be found in Section 6.8.2 and Chapter 7.

6.6.1.4 Vertical Design

Mini-roundabouts should be designed to be outward draining to place the central island at the highest point of the intersection for maximum visibility. This is consistent with most standard intersection grading, where the high point is located near the center of the intersection and sloping toward the outer curb lines. Therefore, in most retrofit situations, installation of a mini-roundabout would not necessarily require significant re-grading of the intersection.

6.6.2 DESIGN CONSIDERATIONS FOR MINI-ROUNDABOUTS AT THREE-LEG INTERSECTIONS

Typical T-intersections with perpendicular approach legs can present challenges to achieving deflection within the existing right-of-way. Exhibit 6-42 illustrates the simplest and least costly method for implementing a mini-roundabout at a standard T-intersection. The inscribed circle of the roundabout is located within the existing curb lines, which requires no additional right-of-way or modifications outside the existing intersection footprint. However, the downside of such a design is that little or no deflection is provided along the top of the T for a driver moving from right to left. Therefore, this type of design is best suited for locations where speeds are already low or where supplemental traffic calming devices can be provided upstream of the roundabout entry.

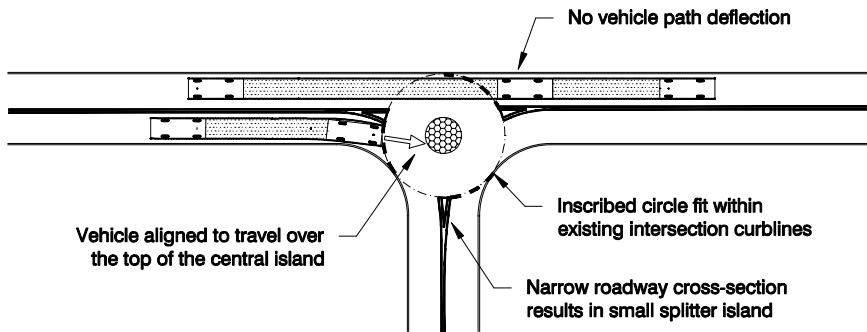

Exhibit 6-42
Mini-Roundabout within Existing Intersection Footprint

Care must be taken in the splitter island design to provide adequate deflection for traffic traveling from left to right across the top of the T to be directed to circulate around the central island rather than simply traveling over top of it. Insufficient

deflection may lead to additional vehicle conflicts and premature wearing of the central island markings.

The preferred option for a mini-roundabout at a T-intersection is to deflect the outer curb line at the top of the T to provide deflection for all movements, as illustrated in Exhibit 6-43. This option may also allow for a slightly larger inscribed circle diameter, which will increase flexibility for larger vehicles to more easily navigate the intersection. Modifications to the curb lines will result in higher costs for this alternative and may also require additional right-of-way.

Exhibit 6-43
Mini-Roundabout with
Central Island Centered
Along Major Roadway

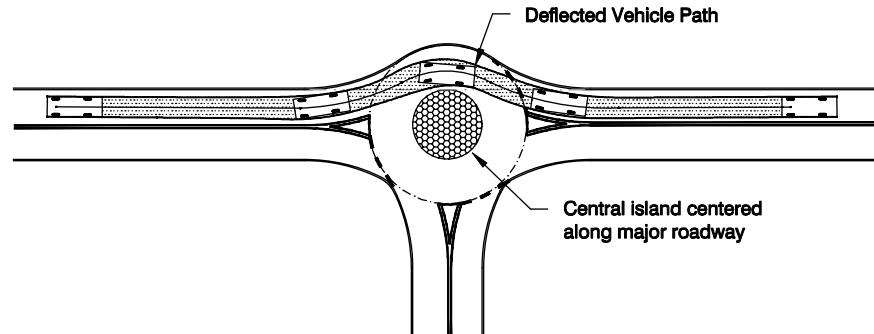

A third option achieves deflection for all movements by shifting the inscribed circle along the minor street axis, as illustrated in Exhibit 6-44. This option will likely require modification of all intersection curb lines and may require additional realignment of the approach legs upstream of the intersection. Care must be taken to sufficiently shift the central island to actually achieve deflection. Minor shifts of one or two feet are not likely to provide sufficient deflection because drivers will be able to simply pick a path that avoids the curb line bump-outs. Minor shifts may also be difficult to perceive by drivers and could result in vehicles running into the bump-outs.

Exhibit 6-44
Mini-Roundabout with
Inscribed Circle Shifted
Along Minor Street Axis

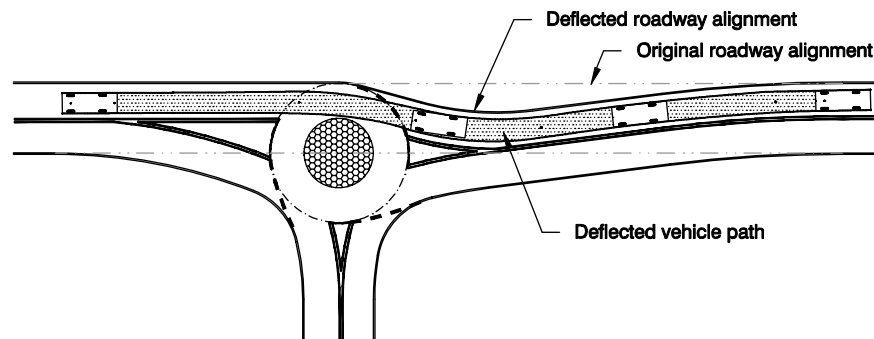

6.6.3 RIGHT-TURN BYPASS LANES

Right-turn bypass lanes can also be used at mini-roundabouts. Exhibit 6-45 shows an example. See Section 6.8.6 for further discussion.



Lutherville, Maryland

Exhibit 6-45
Mini-Roundabout with
Right Turn Bypass Lane

6.7 PERFORMANCE CHECKS

Performance checks are a vital part of roundabout design. These checks help an engineer determine whether the design meets its performance objectives.

6.7.1 FASTEST PATH

The fastest path allowed by the geometry determines the negotiation speed for that particular movement into, through, and exiting the roundabout. It is the smoothest, flattest path possible for a single vehicle, in the absence of other traffic and ignoring all lane markings. The fastest path is drawn for a vehicle traversing through the entry, around the central island, and out the relevant exit. The fastest paths must be drawn for all approaches and all movements, including left-turn movements (which generally represent the slowest of the fastest paths) and right-turn movements (which may be faster than the through movements at some roundabouts). Note that the fastest path methodology does not represent expected vehicle speeds, but rather theoretical attainable entry speeds for design purposes. Actual speeds can vary substantially based on vehicles suspension, individual driving abilities, and tolerance for gravitational forces.

Exhibit 6-46 illustrates the five critical path radii that must be checked for each approach. R_1 , the *entry path radius*, is the minimum radius on the fastest through path prior to the entrance line. R_2 , the *circulating path radius*, is the minimum radius on the fastest through path around the central island. R_3 , the *exit path radius*, is the minimum radius on the fastest through path into the exit. R_4 , the *left-turn path radius*, is the minimum radius on the path of the conflicting left-turn movement. R_5 , the *right-turn path radius*, is the minimum radius on the fastest path of a right-turning vehicle. It is important to note that these vehicular path radii are not the same as the curb radii. The R_1 through R_5 radii measured in this procedure represent the vehicle centerline in its path through the roundabout. Information on constructing the fastest paths is provided in Section 6.7.1.1

Exhibit 6-46
Vehicle Path Radii

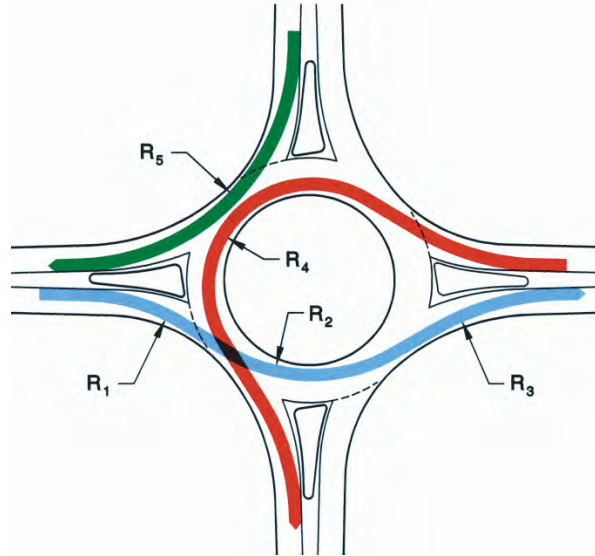

Recommended maximum theoretical entry design speeds for roundabouts at various intersection site categories are provided in Exhibit 6-47.

Exhibit 6-47
Recommended Maximum
Entry Design Speeds

Site Category	Recommended Maximum Theoretical Entry Design Speed
Mini-Roundabout	20 mph (30 km/h)
Single Lane	25 mph (40 km/h)
Multilane	25 to 30 mph (40 to 50 km/h)

Roundabout speed is determined by the fastest path allowed by the geometry.

Through movements are usually the fastest path, but sometimes right-turn paths are more critical.

Draw the fastest path for all roundabout approaches.

6.7.1.1 Construction of Vehicle Paths

To determine the speed of a roundabout, the fastest path allowed by the geometry is drawn. This is the smoothest, flattest path possible for a single vehicle, in the absence of other traffic and ignoring all lane markings, traversing through the entry, around the central island, and out the exit. The design speed of the roundabout is determined from the smallest radius along the fastest allowable path. The smallest radius usually occurs on the circulatory roadway as the vehicle curves to the left around the central island.

A vehicle is assumed to be 6 ft (2 m) wide and maintain a minimum clearance of 2 ft (0.5 m) from a roadway centerline or concrete curb and flush with a painted edge line (3). Thus the centerline of the vehicle path is drawn with the following distances to the particular geometric features:

- 5 ft (1.5 m) from a concrete curb,
- 5 ft (1.5 m) from a roadway centerline, and
- 3 ft (1.0 m) from a painted edge line.

Exhibit 6-48 and Exhibit 6-49 illustrate the construction of the fastest vehicle paths at a single-lane roundabout and at a multilane roundabout, respectively. Exhibit 6-50 provides an example of an approach at which the right-turn path is

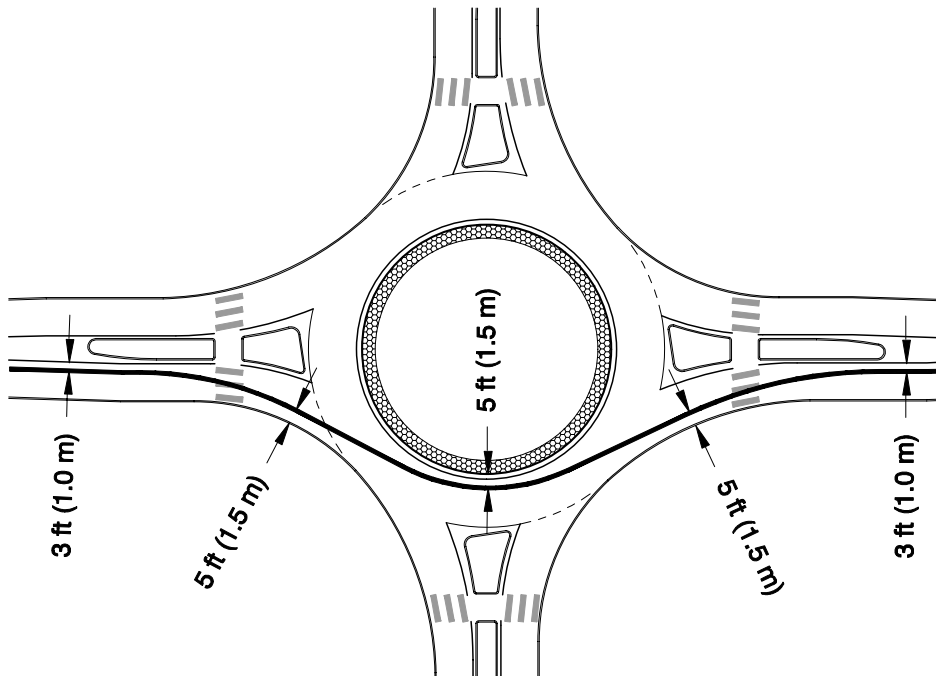

Exhibit 6-48
Fastest Vehicle Path through
Single-Lane Roundabout

more critical than the through movement. The fastest path should be drawn and checked for all approaches of the roundabout.

The fastest path for the through movement is a series of reverse curves (i.e., a curve to the right followed by a curve to the left followed by a curve to the right). When drawing the path, a short length of tangent should be drawn between consecutive curves to account for the time it takes for a driver to turn the steering wheel. Fastest paths may be drawn either freehand or with a computer aided drafting (CAD) program. The freehand technique can provide a natural representation of the way a driver negotiates the roundabout, with smooth transitions connecting curves and tangents. Having sketched the fastest path, the engineer can

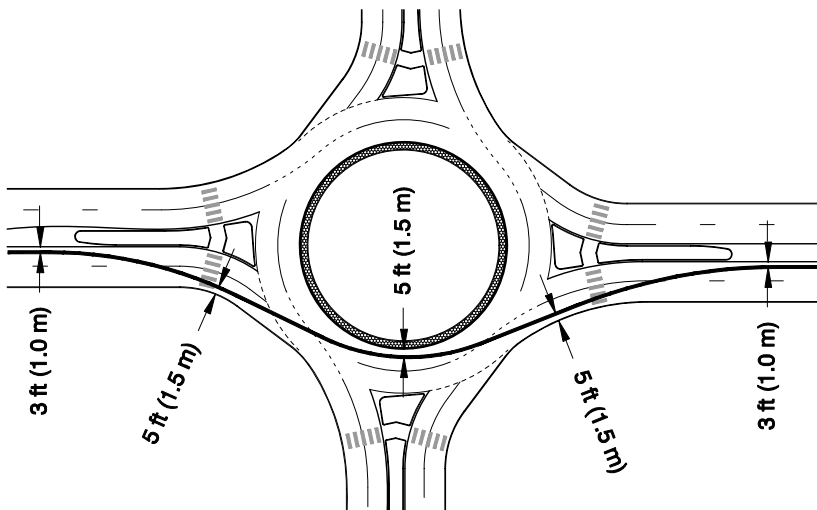
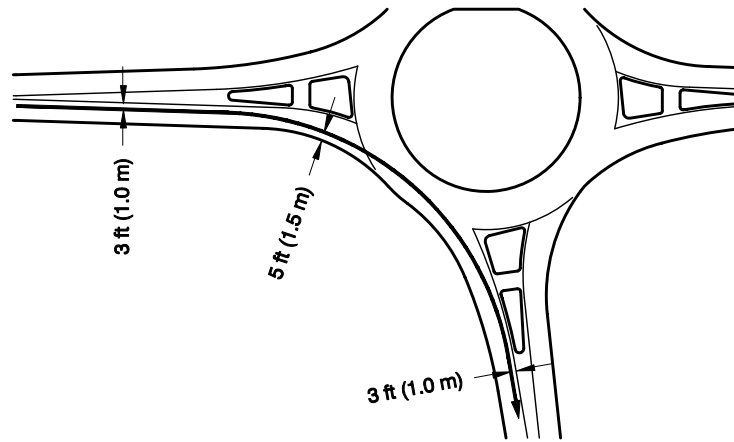

Exhibit 6-49
Fastest Vehicle Path through
Multilane Roundabout

Exhibit 6-50
Example of Critical
Right-Turn Movement



then measure the minimum radii using suitable curve templates or by replicating the path in CAD and using it to determine the radii. The Wisconsin Department of Transportation *Roundabout Guide* (7) provides one possible technique for creating fastest paths in CAD.

The entry path radius, R_1 , is a measure of the deflection imposed on a vehicle prior to entering the roundabout. The ability of the roundabout to control speed at the entry is a proxy for determining the potential safety of the roundabout and whether drivers are likely to yield to circulating vehicles (9). Additional guidance is provided in Exhibit 6-51 on drawing and measuring the R_1 radius. The construction of the fastest path should begin at least 165 ft (50 m) prior to the entrance line using the appropriate offsets identified above. The R_1 radius should be measured as the smallest best-fit circular curve over a distance of at least 65 to 80 ft (20 to 25 m) near the entrance line. This procedure is provided as guidance based upon design standards from the United Kingdom (9); however, other methods may provide equally acceptable results.

Exhibit 6-51
Guidance on Drawing and
Measuring the Entry
Path Radius

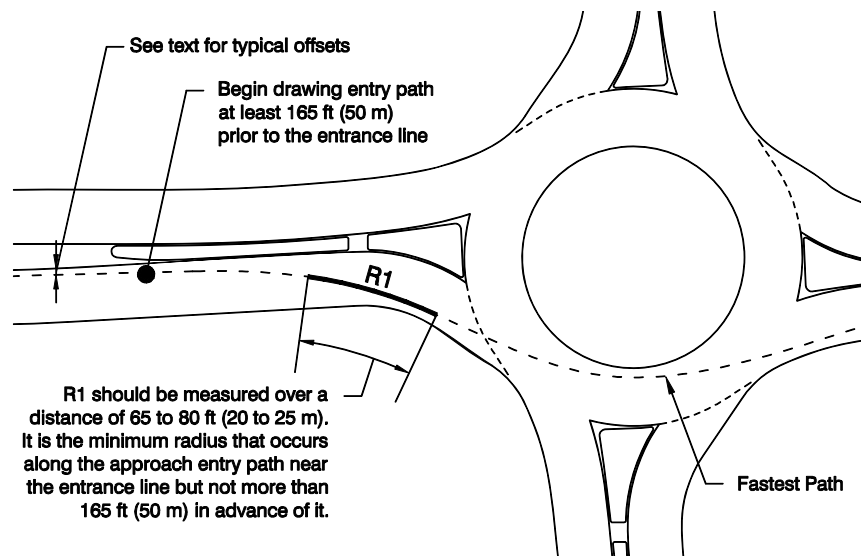

6.7.1.2 Vehicle Speed Estimation

The relationship between travel speed and horizontal curvature is documented in the AASHTO “Green Book” (4). Both superelevation and the side friction factor affect the speed of a vehicle. Side friction varies with vehicle speed and can be determined in accordance with AASHTO guidelines. The most common superelevation values encountered are +0.02 and -0.02, corresponding to 2% cross slope. Equation 6-1 and Equation 6-2 provide a simplified relationship between speed and radius for these two common superelevation rates that incorporates the AASHTO relationship and side friction factors. Exhibit 6-52 illustrates the speed–radius relationship in a graphical format. Additional information regarding the relationship of speed to superelevation and side friction is provided in Appendix D.

$$V = 3.4415R^{0.3861}, \text{ for } e = +0.02$$

Equation 6-1

$$V = 3.4614R^{0.3673}, \text{ for } e = -0.02$$

Equation 6-2

where

- V = predicted speed, mph;
- R = radius of curve, ft; and
- e = superelevation, ft/ft.

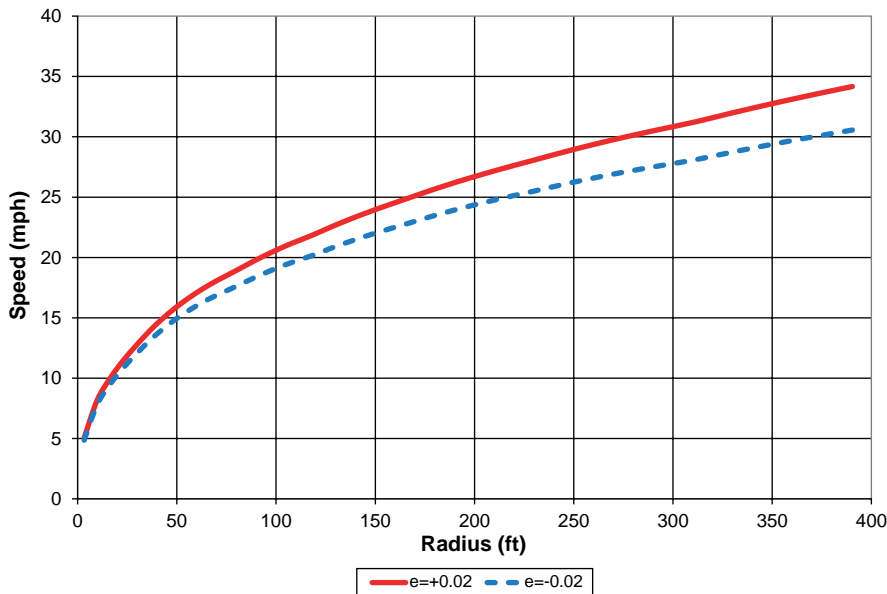

Exhibit 6-52
Speed–Radius Relationship

The speed–radius relationship given above generally provides a reasonable prediction for the left-turn and through movement circulating speeds. However, this method does not consider the effects of deceleration and acceleration and therefore may overpredict entry and exit speeds in cases where the path radius is large (1).

To better predict actual entry speeds, Equation 6-3 may be used to account for deceleration of vehicles from the entering (R_1) speed to the circulating (R_2)

speed. Analysts should use caution in using deceleration as a limiting factor to establish entry speeds for design. To promote safe design, deflection of the R_1 path radius should be the primary method for controlling entry speed. Therefore, while Equation 6-3 may provide an improved estimate of actual speed achieved at entry, for design purposes it is recommended that predicted speeds from Equation 6-1 be used.

Equation 6-3

$$V_1 = \min \left\{ \begin{array}{l} V_{1pbase} \\ \frac{1}{1.47} \sqrt{(1.47V_2)^2 + 2a_{12}d_{12}} \end{array} \right\}$$

where

V_1 = entry speed, mph;

V_{1pbase} = V_1 speed predicted based on path radius, mph;

V_2 = circulatory speed for through vehicles predicted based on path radius, mph;

a_{12} = deceleration between the point of interest along V_1 path and the midpoint of V_2 path = -4.2 ft/s^2 ; and

d_{12} = distance along the vehicle path between the point of interest along V_1 path and the midpoint of V_2 path, ft.

When identifying the predicted speed for the exit radius, R_3 , the acceleration effects of vehicles can have a more prominent effect on the outcome of the estimated speed. At locations with a large radius or tangential exit, the measured R_3 radius will be so large that the acceleration characteristics of the vehicle will govern the actual speeds that can be achieved. Therefore, tangential exits do not inherently result in excessive exit speeds as compared to exits with some curvature, provided that circulating speeds are low and the distance to the point of interest on the exit (typically the crosswalk) is short. While it is desirable to provide some degree of curvature on the exit to reduce the visual appearance of a straight shot, recent U.S. research indicates that such curvature does not appear to always be the controlling factor for exit speeds (1). Exit speed can be estimated using Equation 6-4.

Equation 6-4

$$V_3 = \min \left\{ \begin{array}{l} V_{3pbase} \\ \frac{1}{1.47} \sqrt{(1.47V_2)^2 + 2a_{23}d_{23}} \end{array} \right\}$$

where

V_3 = exit speed, mph;

V_{3pbase} = V_3 speed predicted based on path radius, mph;

V_2 = circulatory speed for through vehicles predicted based on path radius, mph;

a_{23} = acceleration between the midpoint of V_2 path and the point of interest along V_3 path = 6.9 ft/s^2 ; and

d_{23} = distance along the vehicle path between midpoint of V_2 path and point of interest along V_3 path, ft.

With all predicted speeds, the engineer is cautioned to look at the entire trajectory of the subject movement to determine what speeds are reasonable for each part of the trajectory. The above discussion highlights observed limitations on entry and exit speed based on circulating speed. However, other relationships may exist for a given design. For example, an approach curve prior to the entry (with radius R_0) may govern the speed that can be reached at the entry. A combination of low entry speed and low exit speed may make the theoretical speed of the intervening circulating movement less relevant. More generally, the speed environment leading into the roundabout may govern speeds. An entry coming from a parking lot may have a considerably lower observed entry speed than an entry coming from a high-speed rural roadway, even with the same entry geometry.

Look at the entire trajectory of the subject movement to determine what speeds are reasonable for each part of the trajectory

6.7.1.3 Speed Consistency

Consistency between the speeds of various movements within the intersection can help to minimize the crash rate between conflicting traffic streams. Relative speeds between conflicting traffic streams and between consecutive geometric elements should be minimized such that the maximum speed differential between movements should be no more than approximately 10 to 15 mph (15 to 25 km/h). These values are typically achieved by providing a low absolute maximum speed for the fastest entering movements. As with other design elements, speed consistency should be balanced with other objectives in establishing a design.

6.7.1.4 Improving Fastest Path Vehicle Speeds

Iteration within the design process is an integral part of roundabout design. Often, it takes several iterations to achieve the balanced design objectives that are desired. Size, location, and alignment are commonly at the heart of achieving adequate vehicle speeds. If the sketching of the fastest paths identifies speeds that are above the recommended thresholds, the engineer is encouraged to look at the big picture of the design to evaluate these key variables rather than focusing in on the details. Often, in an attempt to achieve adequate vehicle speeds, engineers will produce overly small entry radii or too narrow entry width, which can impact safety, capacity, and the ability to accommodate heavy vehicles.

At single-lane roundabouts, it is relatively simple to reduce the value of R_1 . Possible options include shifting the alignment of the approach further to the left to achieve a slower entry speed (with the potential trade-off of higher exit speeds that may put pedestrians at risk), increasing the size of the inscribed circle diameter, and in some cases making adjustments to the initial entry width/radii parameters that were selected. At multilane roundabouts it is generally more difficult to produce a balanced design to meet all of the principles. As an example, overly small entry curves may allow the design to meet the fastest path speed recommendations; however, this may also cause the natural path of adjacent traffic streams to overlap.

6.7.2 PATH ALIGNMENT (NATURAL PATH) CONSIDERATIONS

As discussed previously, the fastest path through the roundabout is drawn to ensure that the geometry imposes sufficient curvature to achieve a safe design speed. This path is drawn assuming the roundabout is vacant of all other traffic

and the vehicle cuts across adjacent travel lanes, ignoring all lane markings. In addition to evaluating the fastest path, at multilane roundabouts the engineer should also consider the natural vehicle paths. These are the paths approaching vehicles will naturally take through the roundabout geometry, assuming there is traffic in all approach lanes.

The key consideration in drawing the natural path is to remember that drivers cannot change the direction or speed of their vehicle instantaneously. This means that the natural path does not have sudden changes in curvature; it has transitions between tangents and curves and between consecutive reversing curves. Secondly, it means that consecutive curves should be of similar radius. If a second curve has a significantly smaller radius than the first curve, the driver will be traveling too fast to negotiate the turn and may not be able stay within the lane. If the radius of one curve is drawn significantly smaller than the radius of the previous curve, the path should be adjusted.

To identify the natural path of a given design, it is better to sketch the natural paths over the geometric layout, rather than use a computer drafting program or manual drafting equipment. In sketching the path, the engineer will naturally draw transitions between consecutive curves and tangents, similar to the way a driver would negotiate an automobile. Freehand sketching also enables the engineer to feel how changes in one curve affect the radius and orientation of the next curve. The sketch technique, Exhibit 6-53, allows the engineer to quickly obtain a smooth, natural path through the geometry that may be more difficult to obtain using a computer. Additional discussion of design techniques to avoid path overlap is provided in Section 6.5.4. As a rule of thumb, the design should provide at least one car length of large radius or tangent to adequately align vehicles into the correct lane within the circulatory roadway.

Exhibit 6-53
Natural Vehicle Path Sketched
through Roundabout

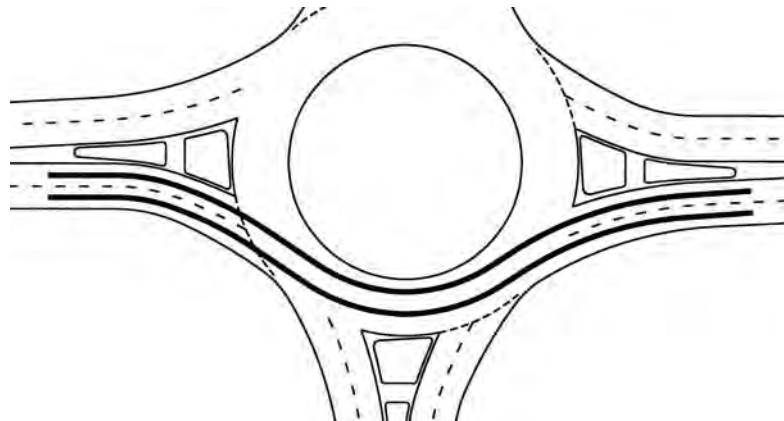

6.7.3 SIGHT DISTANCE

The two most relevant aspects of sight distance for roundabouts are stopping sight distance and intersection sight distance.

6.7.3.1 Stopping Sight Distance

Stopping sight distance is the distance along a roadway required for a driver to perceive and react to an object in the roadway and to brake to a complete stop before reaching that object. Stopping sight distance should be provided at every point within a roundabout and on each entering and exiting approach.

NCHRP Report 400: *Determination of Stopping Sight Distances (19)* recommends the formula given in Equation 6-5 for determining stopping sight distance.

$$d = (1.468)(t)(V) + 1.087 \frac{V^2}{a}$$

Equation 6-5

where

- d = stopping sight distance, ft;
- t = perception–brake reaction time, assumed to be 2.5 s;
- V = initial speed, mph; and
- a = driver deceleration, assumed to be 11.2 ft/s².

Exhibit 6-54 gives stopping sight distances computed from the above equations.

Speed (km/h)	Computed Distance* (m)	Speed (mph)	Computed Distance* (ft)
10	8.1	10	46.4
20	18.5	15	77.0
30	31.2	20	112.4
40	46.2	25	152.7
50	63.4	30	197.8
60	83.0	35	247.8
70	104.9	40	302.7
80	129.0	45	362.5
90	155.5	50	427.2
100	184.2	55	496.7

* Assumes 2.5 s perception–braking time, 3.4 m/s² (11.2 ft/s²) driver deceleration

Exhibit 6-54
Computed Values for Stopping Sight Distance

Stopping sight distance should be measured using an assumed height of driver’s eye of 3.5 ft (1,080 mm) and an assumed height of object of 2 ft (600 mm), in accordance with the AASHTO “Green Book” (4).

At roundabouts, a minimum of three critical types of locations should be checked:

1. Approach sight distance (Exhibit 6-55),
2. Sight distance on circulatory roadway (Exhibit 6-56), and
3. Sight distance to crosswalk on exit (Exhibit 6-57).

Forward sight distance at entry can also be checked; however, this will typically be satisfied by providing adequate stopping sight distance on the circulatory roadway itself.

At least three critical types of locations should be checked for stopping sight distance.

Exhibit 6-55
Stopping Sight Distance
on the Approach

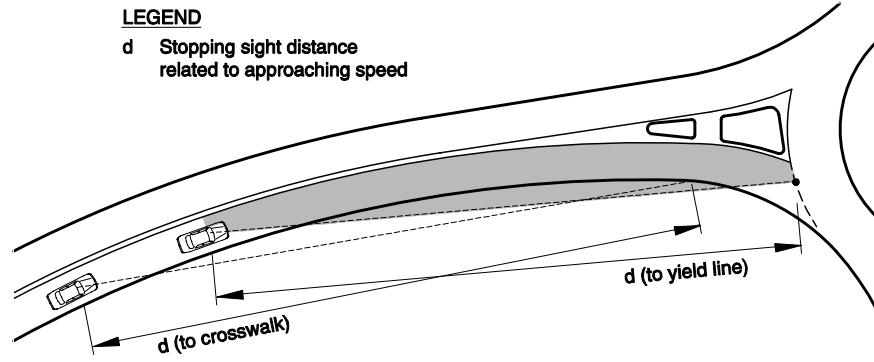

Exhibit 6-56
Stopping Sight Distance
on Circulatory Roadway

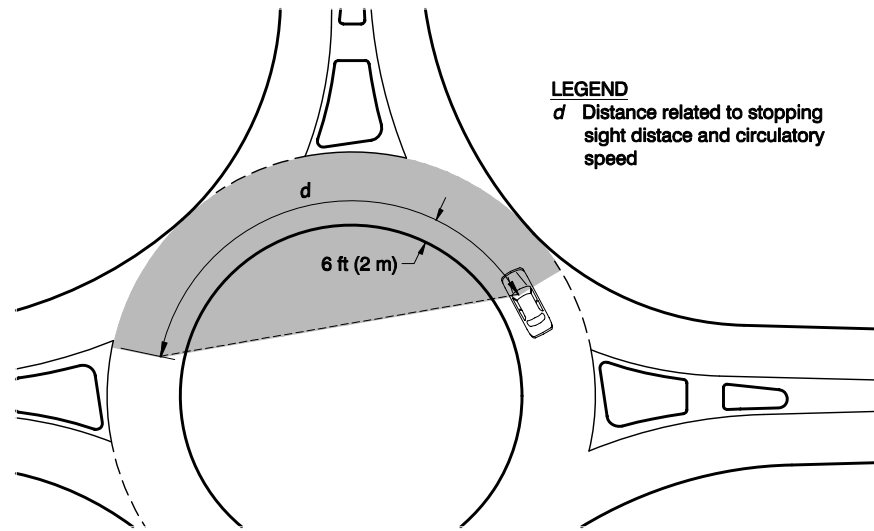
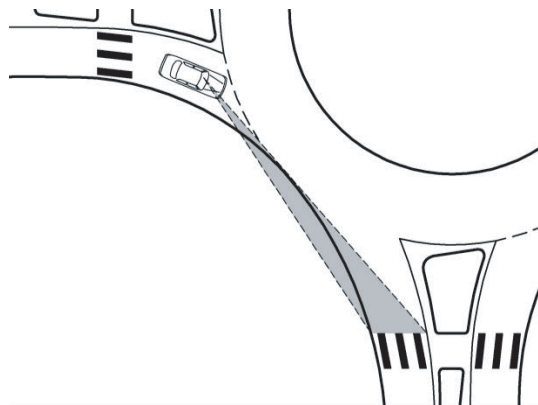

Exhibit 6-57
Sight Distance to
Crosswalk on Exit



6.7.3.2 Intersection Sight Distance

Intersection sight distance is the distance required for a driver without the right-of-way to perceive and react to the presence of conflicting vehicles. Intersection sight distance is achieved through the establishment of *sight triangles* that allow a driver to see and safely react to potentially conflicting vehicles. At roundabouts, the only locations requiring evaluation of intersection sight distance are the entries.

Intersection sight distance is traditionally measured through the determination of a sight triangle. This triangle is bounded by a length of roadway defining a limit away from the intersection on each of the two conflicting approaches and by a line connecting those two limits. For roundabouts, these legs should be assumed to follow the curvature of the roadway, and thus distances should be measured not as straight lines but as distances along the vehicular path.

Intersection sight distance should be measured using an assumed height of driver's eye of 3.5 ft (1,080 mm) and an assumed height of object of 3.5 ft (1,080 mm) in accordance with the AASHTO "Green Book" (4) which is based upon NCHRP Report 383: *Intersection Sight Distances* (20).

Exhibit 6-58 presents a diagram showing the method for determining intersection sight distance. As can be seen in the exhibit, the sight distance triangle has two conflicting approaches that must be checked independently. The following two subsections discuss the calculation of the length of each of the approaching sight limits.

Entries to roundabouts require adequate intersection sight distance.

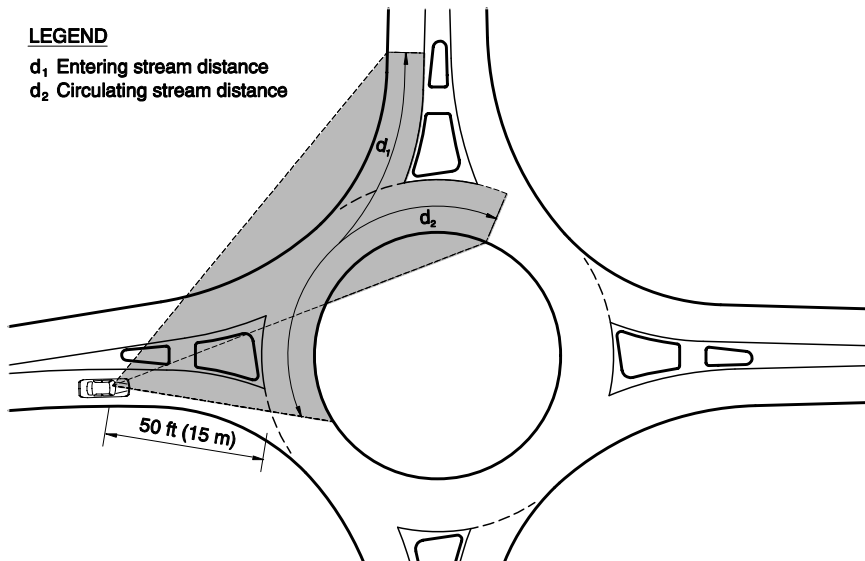

Exhibit 6-58
Intersection Sight Distance

6.7.3.3 Length of Approach Leg of Sight Triangle

The length of the approach leg of the sight triangle should be limited to 50 ft (15 m). British research on sight distance has determined that excessive intersection sight distance results in a higher frequency of crashes. This value, consistent with British and French practice, is intended to require vehicles to slow down prior to entering the roundabout, which supports the need to slow down and yield at the roundabout entry and allows drivers to focus on the pedestrian crossing prior to

entry. If the approach leg of the sight triangle is greater than 50 ft (15 m), it may be advisable to add landscaping to restrict sight distance to the minimum requirements.

6.7.3.4 Length of Conflicting Leg of Sight Triangle

A vehicle approaching an entry to a roundabout faces conflicting vehicles within the circulatory roadway and on the immediate upstream entry. The length of the conflicting leg is calculated using Equation 6-6 and Equation 6-7:

Equation 6-6

$$d_1 = (1.468)(V_{major, entering})(t_c)$$

Equation 6-7

$$d_2 = (1.468)(V_{major, circulating})(t_c)$$

where

- d_1 = length of entering leg of sight triangle, ft;
- d_2 = length of circulating leg of sight triangle, ft;
- V_{major} = design speed of conflicting movement, mph, discussed below; and
- t_c = critical headway for entering the major road, s, equal to 5.0 s.

Two conflicting traffic streams should be checked at each entry:

1. *Entering stream*, which is composed of vehicles from the immediate upstream entry. The speed for this movement can be approximated by taking the average of the theoretical entering (R_1) speed and the circulating (R_2) speed.
2. *Circulating stream*, which is composed of vehicles that enter the roundabout prior to the immediate upstream entry. This speed can be approximated by taking the speed of left-turning vehicles (path with radius R_4).

The critical headway for entering the major road is based on the amount of time required for a vehicle to safely enter the conflicting stream. The critical headway value of 5.0 s given in Equation 6-6 and Equation 6-7 is based upon the critical headway required for passenger cars (2). This critical headway value represents an interim methodology pending further research. Some individual states or municipalities have elected to use alternative critical headway values ranging from 4.5 to 6.5 seconds. Exhibit 6-59 shows computed length of the conflicting leg of an intersection sight triangle.

Exhibit 6-59
Computed Length of
Conflicting Leg of
Intersection Sight Triangle

Conflicting Approach Speed (mph)	Computed Distance (ft)	Conflicting Approach Speed	
		(km/h)	Computed Distance (m)
10	73.4	20	27.8
15	110.1	25	34.8
20	146.8	30	41.7
25	183.5	35	48.7
30	220.2	40	55.6

Note: Computed distances are based on a critical headway of 5.0 s.

Providing more than the minimum required intersection sight distance can lead to higher speeds that reduce intersection safety.

In most cases it is best to provide no more than the minimum required intersection sight distance on each approach. Excessive intersection sight distance can lead to higher vehicle speeds that reduce the safety of the intersection for all road users (motorists, bicyclists, pedestrians). Landscaping can be effective in restricting sight distance to the minimum requirements.

6.7.3.5 Combined Sight Distance Diagram

During design and review, roundabouts should be checked to ensure that adequate stopping and intersection sight distance is being provided. Checks for each approach should be overlaid onto a single drawing, as shown in Exhibit 6-60, to illustrate the clear vision areas for the intersection. This provides guidance on the appropriate locations for various types of landscaping or other treatments. Landscaping can be effective in restricting sight distance to the minimum needed and provides an important mechanism for alerting drivers to the presence and location of the roundabout.

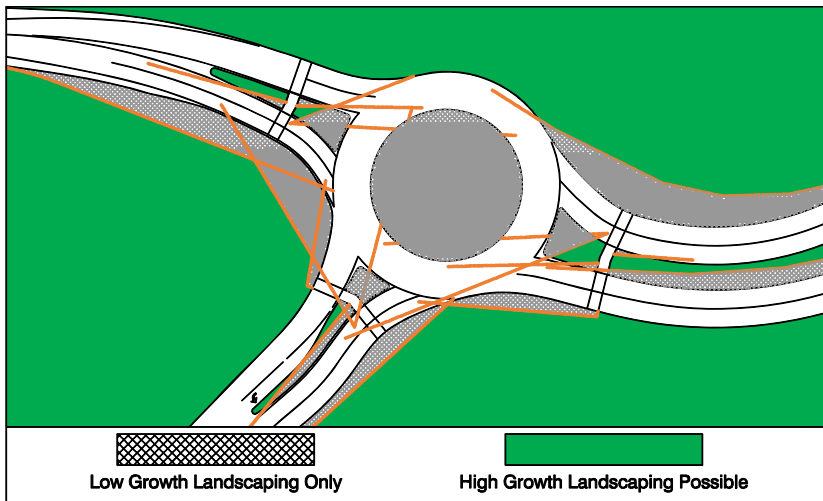

Exhibit 6-60
Example Sight
Distance Diagram

The hatched portions in Exhibit 6-60 are areas that should be clear of large obstructions that may hinder driver visibility. Objects such as low growth vegetation, poles, sign posts, and narrow trees may be acceptable within some of these areas provided that they do not create a hazard for errant vehicles or significantly obstruct the visibility of other vehicles, pedestrians, the splitter islands, the central island, or other key roundabout components. In the remaining areas (with solid shading), especially within the central island, taller landscaping may be used to break the forward view for through vehicles, thereby contributing to speed reductions and reducing oncoming headlight glare. Note that other factors like speed environment may further control landscaping design; refer to Chapter 9 for more discussion.

6.7.4 ANGLES OF VISIBILITY

The intersection angle between consecutive entries must not be overly acute in order to allow drivers to comfortably turn their heads to the left to view oncoming traffic from the immediate upstream entry. The intersection angle between consecutive entries, and indeed the angle of visibility to the left for all entries, should conform to the same design guidelines as for conventional intersections. Guidance for designing for older drivers and pedestrians recommends using 75° as a minimum intersection angle (21).

At roundabouts, the intersection angle may be measured as the angle between a vehicle's alignment at the entrance line and the sight line required according to intersection sight-distance guidelines. Exhibit 6-61 shows an example design with a severe angle of visibility to the left, and Exhibit 6-62 shows a possible correction. Note that in any complex roundabout like this one, corrections for one effect may introduce other challenges, such as the closer proximity of the entrance in the lower left corner of the exhibit to the entrance in the lower right corner. The engineer needs to balance trade-offs when determining the best course of action.

Exhibit 6-61
Example Design with Severe
Angle of Visibility to Left

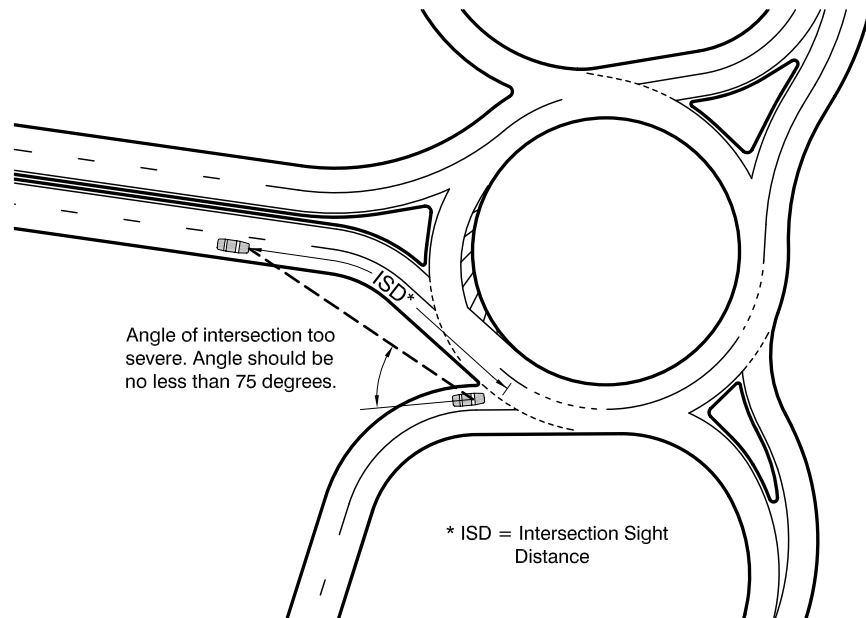

Source: California Department of Transportation (1)

Exhibit 6-62
Roundabout with Realigned
Ramp Terminal Approach
to Provide Better Angle
of Visibility to Left

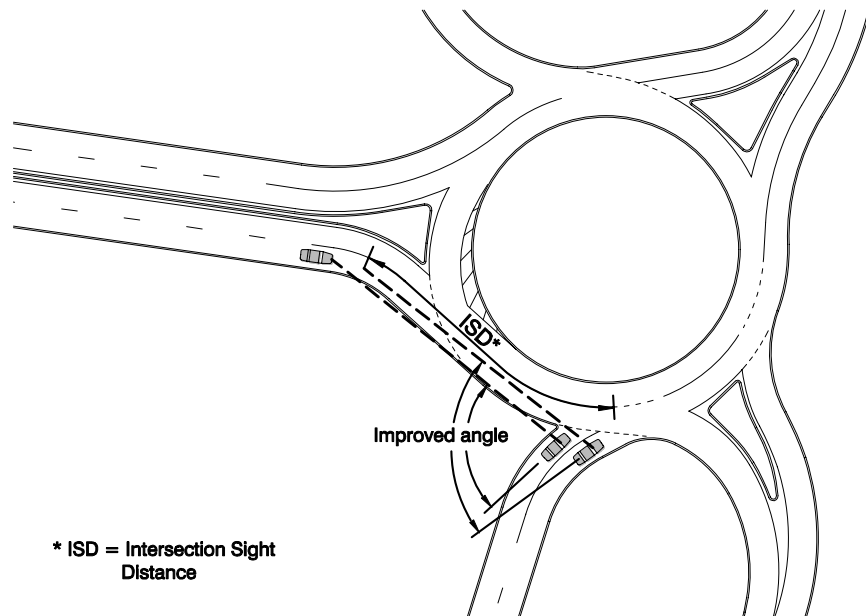

Source: California Department of Transportation (1)

6.8 DESIGN DETAILS

This section provides a discussion of a variety of design details that are common to all types of roundabouts.

6.8.1 PEDESTRIAN DESIGN CONSIDERATIONS

6.8.1.1 Sidewalks

Wherever possible, sidewalks at roundabouts should be set back from the edge of the circulatory roadway with a landscape strip. Landscape strips provide many benefits, including increased comfort for pedestrians, room for street furniture and snow storage, and a buffer to allow for the overhang of large vehicles as they navigate the roundabout. Two additional important benefits are that the setback discourages pedestrians from crossing to the central island or cutting across the circulatory roadway of the roundabout and that the setback helps guide pedestrians with vision impairments to the designated crosswalks.

The draft Public Rights-of-Way Accessibility Guidelines (PROWAG) (22) include a requirement to provide a detectable edge treatment between sidewalks and roundabouts wherever pedestrian crossings are not intended. A recommended setback distance of 5 ft (1.5 m) should be used [minimum of 2 ft (0.6 m)], and it is best to plant low shrubs or grass in the area between the sidewalk and curb (see Chapter 7). Where there is not enough room to provide adequate setback, fencing or other barriers may be necessary to guide pedestrians with vision impairments to the crosswalks. Fencing may also be advantageous in areas where high numbers of pedestrians make pedestrian entry into the circulatory roadway likely (e.g., on a college campus). Exhibit 6-63 and Exhibit 6-64 provide examples of sidewalk treatments.

Set back sidewalks 1.5 m (5 ft) from the circulatory roadway where possible.

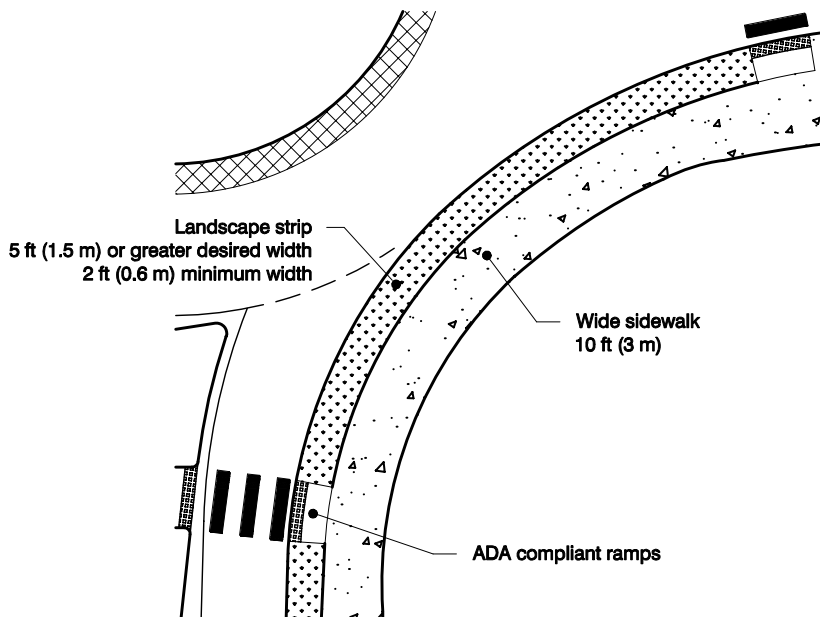
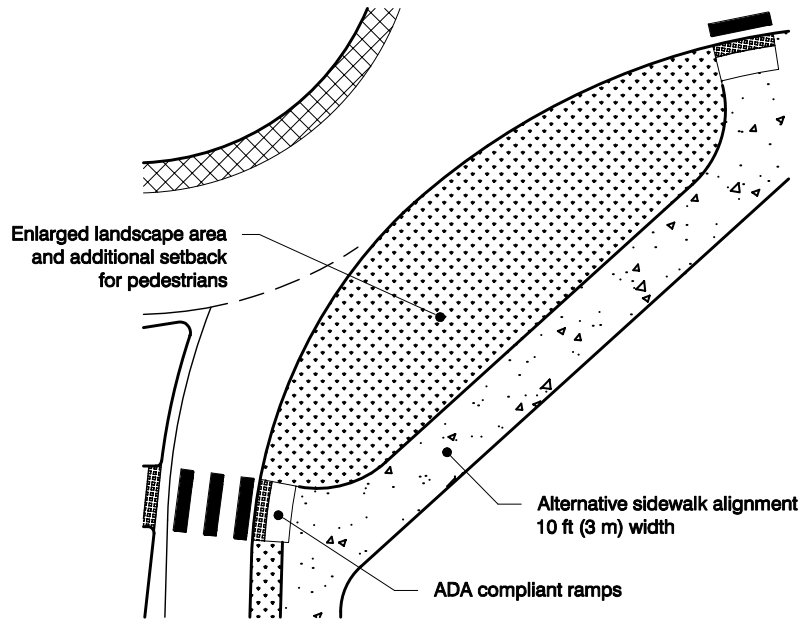

Exhibit 6-63
Sidewalk Treatment Example

Exhibit 6-64
Alternative Sidewalk
Treatments



The recommended sidewalk width at roundabouts is 6 ft (1.8 m), and the minimum width is 5 ft (1.5 m). In areas with heavy pedestrian volumes, sidewalks should be as wide as necessary to accommodate the anticipated pedestrian volume. At any roundabout where ramps provide sidewalk access to bicyclists, the sidewalk should be a minimum of 10 ft (3 m) wide to accommodate shared use by pedestrians and bicyclists. An example of sidewalk setback is given in Exhibit 6-65.

Exhibit 6-65
Example Sidewalk Setback
at Roundabouts

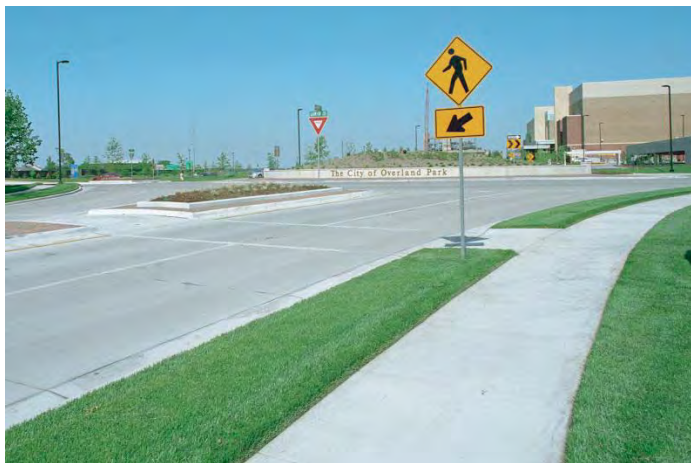

Overland Park, Kansas

6.8.1.2 Crosswalks

Pedestrian crosswalk placement at roundabouts requires consistency, based on a balance between pedestrian convenience, pedestrian safety, and roundabout operations:

- *Pedestrian convenience:* Pedestrians desire crossing locations as close to the roundabout as possible to minimize out-of-direction travel. The further

the crossing is from the roundabout, the more likely pedestrians will choose a shorter route that may put them in greater danger. On the other hand, placing crosswalks at distances away from the entrance line that are approximately in increments of vehicle lengths reduces the chance that queued vehicles will be stopped on the crosswalk, blocking convenient crossing movements by pedestrians.

- *Pedestrian safety:* Both crossing distance and crossing location are important. Crossing distance should be minimized to reduce exposure of pedestrians to vehicular conflicts. Due to the flared entry at most roundabouts, crosswalk placement somewhat back from the entrance line will result in shorter crossing distance. Placing crosswalks back also helps drivers first focus their attention on the pedestrian crosswalk before moving forward and focusing their attention to the left to look for gaps in the circulating traffic stream.
- *Roundabout operations:* Vehicular roundabout operations can also be affected by crosswalk locations, particularly on the exit. A queuing analysis at the exit crosswalk may determine that a crosswalk location of more than one vehicle length may be desirable to reduce the likelihood of queuing into the circulatory roadway. Pedestrians may more easily be able to visually distinguish exiting vehicles from circulating vehicles at crosswalks located further from the roundabout.

With these ideas in mind, pedestrian crosswalks should be designed as follows:

- The raised splitter island width should be a minimum of 6 ft (1.8 m) at the crosswalk to adequately provide shelter for persons pushing a stroller or walking a bicycle (see Section 6.2.5).
- Pedestrian crossings should ideally be located in vehicle-length increments away from the edge of the circulatory roadway, or the yield line if one is provided. A typical and minimum crosswalk setback of 20 ft (6 m) is recommended. This is the length of one vehicle without any additional distance to account for the gap between vehicles, since ideally the crosswalk is placed within this gap. At some roundabouts, it may be desirable to place the crosswalk two or three car lengths [45 ft (13.5 m) or 70 ft (21.5 m)] back from the edge of the circulatory roadway; note that these dimensions include a 5 ft (1.5 m) gap between queued vehicles. The approach and exit geometry at roundabouts often makes it impractical to keep the crosswalk setback at a consistent distance from the edge of the circulatory roadway.
- There are two options for the alignment of a pedestrian crosswalk at roundabouts:
 - Place each leg of the crosswalk approximately perpendicular to the outside curb of the circulatory roadway for both the entry lane(s) and the exit lane(s). This creates an angle point in the walkway across the splitter island (see Exhibit 6-66). The advantages of this design are that it creates the shortest possible total crossing distance and makes it easier to build accessible ramps to the sidewalk, since the crossing is perpendicular to the curb.

Exhibit 6-66
Crosswalk Alignment Options

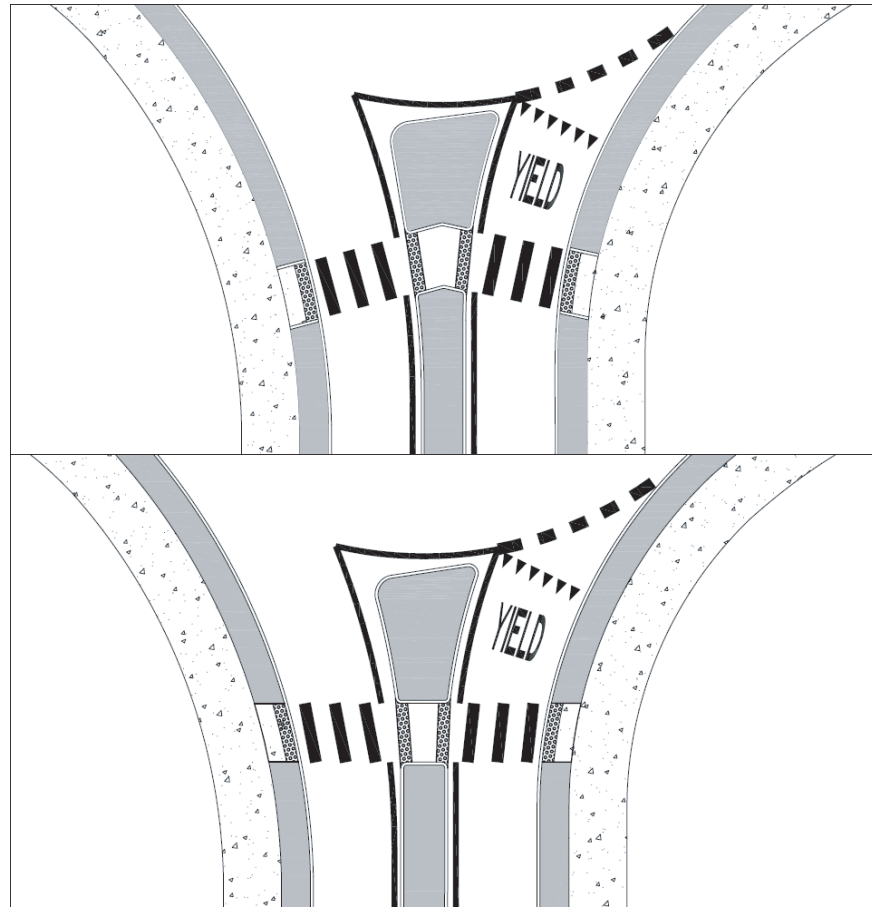

- Place the entire crosswalk perpendicular to the centerline of the approach roadway. This results in angled crossings of the entry and exit lanes. The advantages of this design are a shorter overall walking distance for pedestrians and less variability in the distance between the edge of the circulatory roadway and the crosswalk. However, this can result in fairly long and overly skewed crosswalks at roundabouts where the entry lane(s) and/or exit lane(s) are angled significantly at the crosswalk location. In addition, since the curb ramp still needs to be perpendicular to the curb for mobility-impaired users, the curb ramp may not be aligned parallel with the crosswalk in order to provide alignment cues to visually impaired pedestrians.
- The walkway through the splitter island should be cut through instead of ramped. This is less cumbersome for wheelchair users and allows the cut-through walkway to be aligned with the crosswalks, providing guidance for all pedestrians, but particularly for those who are blind or who have low vision. The cut-through walkway should be approximately the same width as the crosswalk, ideally a minimum width of 10 ft (3.0 m).
- Sidewalk ramps must be provided to connect to the sidewalks at each end of the crosswalk. Wherever sidewalks are set back from the roundabout

with a planting strip as recommended above, ramps do not need to have flares and should simply have curbed edges aligned with the crosswalk. This provides alignment cues for pedestrians, especially those who are blind or who have low vision. Additional guidelines related to accessible curb ramp design can be found in the PROWAG as well as other documents published by the Access Board.

- Detectable warning surfaces consisting of raised truncated domes, as required by accessibility guidelines, should be applied to the ramps and also along the full width of the cut-through walkway within the splitter island. The detectable warning surface on splitter islands should begin at the curb line and extend into the cut-through area a distance of 2 ft (0.6 m). This results in a minimum 2 ft (0.6 m) clear space between detectable warning surfaces on a splitter island with the minimum recommended width of 6 ft (1.8 m) at the pedestrian crossing. Detailed standards for detectable warning surfaces can be found in the PROWAG published by the Access Board.
- Crosswalk markings should be installed on all roundabout approaches where sidewalks and ramps lead to pedestrian crossings. Additional information on crosswalk markings can be found in Chapter 7.

Raised crosswalks (speed tables with pedestrian crossings on top) are another design treatment that can encourage slow vehicle speeds where pedestrians cross. As described elsewhere in this document, good geometric design is important at all roundabouts to encourage slow vehicle speeds. Raised crosswalks may be beneficial to reduce vehicles speeds at any location where vehicle speeds are higher than desirable at crosswalk locations. Raised crosswalks also make crossings very easy for pedestrians with mobility impairments, who will not need to go up and down ramps as much as they would otherwise. Raised crosswalks need to have detectable warnings as described above to clearly delineate the edge of the street.

6.8.2 BICYCLE DESIGN CONSIDERATIONS

Safety and usability of roundabouts for bicyclists depends on the details of the roundabout design and special provisions for bicyclists. At roundabouts, some cyclists may choose to travel like other vehicles, while others may choose to travel like pedestrians. Roundabouts can be designed to simplify this choice for cyclists.

Since typical on-road bicycle travel speeds are between 12 and 20 mph (19 to 32 km/h), roundabouts that are designed to constrain the speeds of motor vehicles to similar values will minimize the relative speeds between bicyclists and motorists, and thereby improve safety and usability for cyclists. As described in Section 6.2, roundabouts designed for urban conditions should have a recommended maximum entry speed of 20 to 30 mph (32 to 48 km/h); these roundabouts are generally compatible with bicycle travel.

Single-lane roundabouts are much simpler for cyclists than multilane roundabouts since they do not require cyclists to change lanes to make left-turn movements or otherwise select the appropriate lane for their direction of travel. In addition, at single-lane roundabouts, motorists are less likely to cut off cyclists when exiting the roundabout. Therefore, it is important not to select a multilane roundabout over a single-lane roundabout in the short term, even when long-term

traffic predictions suggest that a multilane roundabout may be desirable. In addition, the use of a roundabout with two-lane entries for the major roadway and one-lane entries for the minor roadway can be a good solution to minimize complexity for bicyclists where a roundabout is proposed at an intersection of a major multilane street and a minor street.

6.8.2.1 Designing for Bicyclists to Traverse Roundabouts like Vehicles

In general, cyclists who have the knowledge and skills to ride effectively and safely on collector roadways can navigate low-speed, single-lane roundabouts without much difficulty. Cyclists and motorists will travel at approximately the same speed, making it easier for bicyclists to merge with other vehicular traffic and take the lane within the roundabout itself; these are necessary actions for safe bicycling in a roundabout. Even at multilane roundabouts, many cyclists will be comfortable traveling through like other vehicles.

Where bicycle lanes or shoulders are used on approach roadways, they should be terminated in advance of roundabouts. The full-width bicycle lane should normally end at least 100 ft (30 m) before the edge of the circulatory roadway. Terminating the bike lane helps remind cyclists that they need to merge. An appropriate taper should be provided to narrow the sum of the travel lane and bike lane widths down to the appropriate width necessary to achieve desired motor vehicle speeds on the roundabout approach. The taper should end prior to the crosswalk at the roundabout to achieve the shortest possible pedestrian crossing distance. A taper rate of 7:1 is recommended to accommodate a design speed of 20 mph (30 km/h), which is appropriate for bicyclists and motor vehicles approaching the roundabout. To taper a 5 ft to 6 ft (1.4 m to 1.8 m) wide bicycle lane, a 40 ft (12.2 m) taper is recommended. The bicycle lane line should be dotted for 50 to 200 ft (15 m to 60 m) prior to the beginning of the taper and dropped entirely through the taper itself. A longer dotted line gives advance notice to cyclists that they need to merge, providing more room for them to achieve this maneuver and find an appropriate gap in traffic.

Bicycle lanes should not be located within the circulatory roadway of roundabouts. This would suggest that bicyclists should ride at the outer edge of the circulatory roadway, which can increase crashes resulting from exiting motorists who cut off circulating bicyclists and from entering motorists who fail to yield to circulating bicyclists.

At roundabout exits, an appropriate taper should begin after the crosswalk, with a dotted line for the bike lane through the taper. The solid bike lane line should resume as soon as the normal bicycle lane width is available.

6.8.2.2 Designing for Bicyclists to Traverse Roundabouts like Pedestrians

Because some cyclists may not feel comfortable traversing some roundabouts in the same manner as other vehicles, bicycle ramps can be provided to allow access to the sidewalk or a shared use path at the roundabout. Bicycle ramps at roundabouts have the potential to be confused as pedestrian ramps, particularly for pedestrians who are blind or who have low vision. Therefore, bicycle ramps should only be used where the roundabout complexity or design speed may result in less comfort for some bicyclists. Ramps should not normally be used at urban, one-lane round-

Bicycle lanes should not be placed around the outside of the circulatory roadway of roundabouts.

Ramps to provide sidewalk access for bicyclists can be confusing for pedestrians who are blind or have low vision, so bicycle ramps should only be used at roundabouts where some cyclists may have difficulty circulating like other vehicles.

abouts. As described in Section 6.8.2, multilane roundabouts are more challenging for cyclists, and bike ramps can be used to provide the option to travel through the roundabout like a pedestrian. Bike ramps may also be appropriate at single-lane roundabouts if traffic speeds or other conditions (e.g., a right turn bypass lane) make circulating like other vehicles more challenging for bicyclists.

Where bicycle ramps are provided at a roundabout, consideration should be given to providing a shared-use path or a widened sidewalk at the roundabout. In areas with relatively low pedestrian use and where bicycle use of the sidewalks is expected to be low, the normal sidewalk width may be sufficient; however, in most situations, a minimum 10 ft (3 m) sidewalk width is recommended. If the sidewalk is designated as a shared-use path, appropriate shared-use path design details should be applied. The reader is encouraged to refer to the *AASHTO Guide for Development of Bicycle Facilities* (23) for a more detailed discussion of the design requirements for shared-use paths.

In some jurisdictions, state or local laws may prohibit cyclists from riding on sidewalks. In these areas, the following options could be considered:

- Bicycle ramps can simply not be used.
- Ramps could be installed using one of the following options:
 - Signs could be posted to remind cyclists that they need to walk their bicycles on the sidewalk.
 - An exception could be made to allow cyclists to ride on the sidewalks at the roundabout; appropriate regulatory signs would need to be posted.
 - The sidewalk could be designed and designated as a shared use path.

The design details of bicycle ramps are critical to provide choice to cyclists, ensure usability by cyclists, and reduce the potential for confusion of pedestrians, particularly those who are blind or who have low vision. Bicycle ramps should be placed at the end of the full-width bicycle lane where the taper for the bicycle lane begins. Cyclists approaching the taper and bike ramp will thus be provided the choice of merging left into the travel lane or moving right onto the sidewalk. Bike ramps should not be placed directly in line with the bike lane or otherwise placed in a manner that appears to cyclists that the bike ramp and the sidewalk is the recommended path of travel through the roundabout. This encourages more sidewalk use by bicyclists, which can have a negative effect on pedestrians at the roundabout and may be less safe for bicyclists as well. Bicycle ramps should be placed at least 50 ft (15 m) prior to the crosswalk.

Whenever possible, bicycle ramps should be placed entirely within the planting strip between the sidewalk and the roadway. In these locations, the bicycle ramps should be placed at a 35° to 45° angle to the roadway and the sidewalk to enable cyclists to use the ramp even if pulling a trailer, but to discourage them from entering the sidewalk at high speed. The bike ramp can be fairly steep, with a slope potentially as high as 20%. If placed within the sidewalk area itself, the ramp slope must be built in a manner so that it is not a tripping hazard. Exhibit 6-67 and Exhibit 6-68 illustrate several possible designs of bike ramps, depending on whether a planting strip is available and the available sidewalk width.

Exhibit 6-67
Possible Treatments
for Bicycles

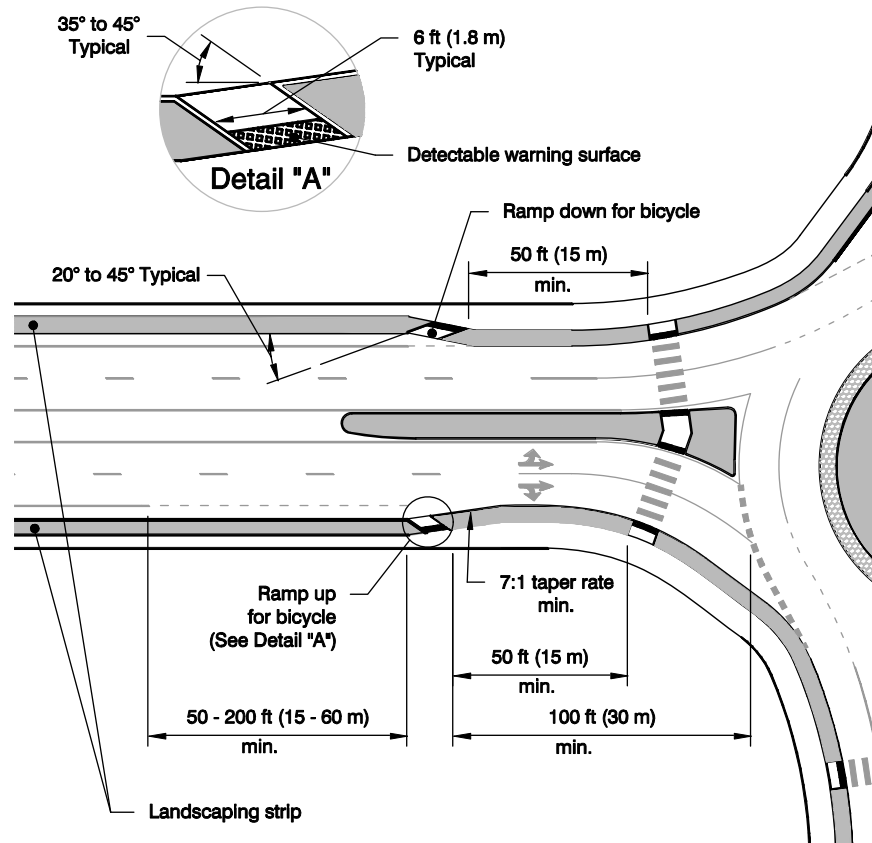
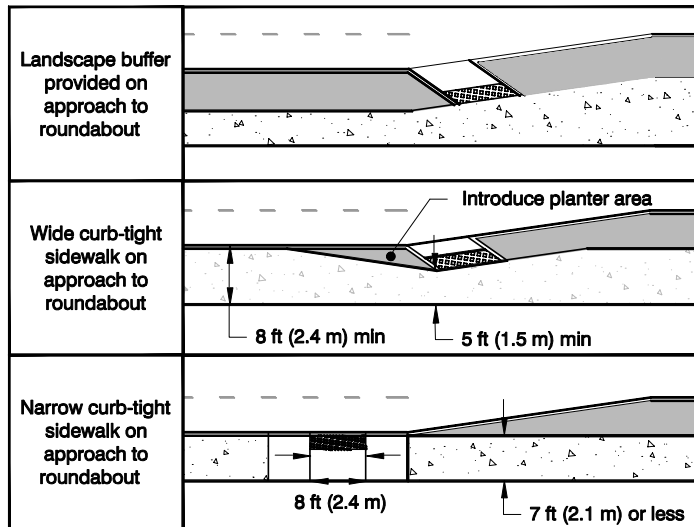

Exhibit 6-68
Bicycle Ramp
Design Options



Since bike ramps can be confusing for pedestrians with vision impairments, detectable warnings should be included on the ramp. Where the ramp is placed in a planter strip, the detectable warning field should be placed at the top of the ramp since the ramp itself is part of the vehicular area for which the detectable warning is used. If the ramp is in the sidewalk itself, the detectable warning should be placed at the bottom of the ramp. Other aspects of the bike ramp design and placement can

help keep pedestrians from misconstruing the bike ramp as a pedestrian crossing location. These aspects include the angle of the ramp, the possible steeper slope of the ramp, and location of the ramp relatively far from the roundabout and crosswalk.

Bicycle ramps at roundabout exits should be built with similar geometry and placement as the ramps at roundabout entries. On exits, the angle between the bike ramp and the roadway can be as small as 20° since it is not necessary to encourage bicyclists to slow down as they reenter the roadway, but some angle is necessary so that blind pedestrians do not inadvertently travel down the ramp. Bike ramps should be placed at least 50 ft (15 m) after the crosswalk at the roundabout exit.

6.8.3 PARKING CONSIDERATIONS

Parking in the circulatory roadway is not conducive to efficient and safe roundabout operations and should typically be prohibited. Parking on entries and exits should also be set back far enough so as not to hinder roundabout operations or to impair the visibility of pedestrians. AASHTO recommends that parking should end at least 20 ft (6.1 m) from the crosswalk of an intersection (4). Curb extensions or bulb-outs are recommended to clearly mark the limit of permitted parking and reduce the width of the entries and exits.

6.8.4 BUS STOP LOCATIONS

For safety and operational reasons, bus stops should be located sufficiently far away from entries and exits and never in the circulatory roadway. Nearside and far-side bus stops should be located and designed as follows:

- *Nearside stops:* If a bus stop is to be provided on the near side of a roundabout, it should typically be located far enough away from the splitter island so that a vehicle overtaking a stationary bus is in no danger of being forced into the splitter island, especially if the bus starts to pull away from the stop. If an approach has only one lane and capacity is not an issue on that entry, the bus stop could be located at the pedestrian crossing in the lane of traffic. This is not recommended for entries with more than one lane because vehicles in the lane next to the bus may not see pedestrians. At multilane roundabouts, a nearside bus stop can be included in the travel lane (a bus bulb-out design), as long as it is set back at least 50 ft (15 m) from the crosswalk. Nearside stops provide the advantage of having a potentially slower speed environment where vehicles are slowing down, compared to a far-side location where vehicles may be accelerating upon exiting the roundabout.
- *Far-side stops:* Bus stops on the far side of a roundabout should be located beyond the pedestrian crossing to improve visibility of pedestrians to other exiting vehicles. Far-side stops result in the crosswalk being behind the bus, which provides for better sight lines for vehicles exiting the roundabout to pedestrians and keeps bus patrons from blocking the progress of the bus when they cross the street. The use of bus pullouts has some trade-offs to consider. A positive feature of a bus pullout is that it reduces the likelihood of queuing behind the bus into the roundabout. A possible negative feature is that a bus pullout may create sight line challenges for the bus driver to see vehicles approaching from behind when

attempting to merge into traffic. It may also be possible at multilane roundabouts in slow-speed urban environments to include a bus stop without a bus pullout immediately after the crosswalk, as exiting traffic has an opportunity to pass the waiting bus.

In a traffic-calmed environment, or close to a school, it may be appropriate to locate the bus stop at a position that prevents other vehicles from passing the bus while it is stopped.

6.8.5 TREATMENTS FOR HIGH-SPEED APPROACHES

Roundabouts located on rural roads often have special design considerations because approach speeds are higher than for urban or local streets, and drivers do not expect to encounter speed interruptions. The primary safety concern in rural locations is to make drivers aware of the roundabout with ample distance to comfortably decelerate to the appropriate speed. The design of a roundabout in a high-speed environment typically employs all of the techniques of roundabouts in a lower-speed environment, with greater emphasis on the items presented in the remainder of this section.

6.8.5.1 Visibility

An important feature affecting safety at rural intersections is the visibility of the intersection itself. Roundabouts are no different from stop-controlled or signalized intersections in this respect except for the presence of curbing along roadways that are typically not curbed. The potential for single-vehicle crashes can be minimized with attention to proper visibility of the roundabout and its approaches. Where possible, the geometric alignment of approach roadways should be constructed to maximize the visibility of the central island and the shape of the roundabout. Where adequate visibility cannot be provided solely through geometric alignment, additional treatments (signing, pavement markings, advanced warning beacons, etc.) should be considered (see Chapter 7). Note that many of these treatments are similar to those that would be applied to rural stop-controlled or signalized intersections.

6.8.5.2 Curbing

On an open rural highway, changes in the roadway's cross section can be an effective means to help approaching drivers recognize the need to reduce their speed. Rural highways typically have no outside curbs with wide paved or gravel shoulders. Narrow shoulder widths and curbs on the outside edges of pavement, on the other hand, generally give drivers a sense they are entering a more controlled setting, causing them to naturally slow down. Thus, when installing a roundabout on an open rural highway, curbs should be provided at the roundabout and on the approaches, and consideration should be given to reducing shoulder widths.

Curbs help to improve delineation and to prevent corner cutting, which helps to ensure low speeds. In this way, curbs help to confine vehicles to the intended design path. The engineer should carefully consider all likely design vehicles, including farm equipment, when setting curb locations. Little research has been performed to date regarding the length of curbing required in advance of a rural roundabout. However, some Australian guidance suggests that curbing should be

Roundabout visibility is a key design element at rural locations.

Curbs should be provided at all rural roundabouts.

provided in advance of the splitter island. It may be desirable to extend the curbing from the approach for at least the length of the required deceleration distance to the roundabout.

6.8.5.3 Splitter Islands

Another effective cross-section treatment to reduce approach speeds is to use longer splitter islands on the approaches (24). Splitter islands should generally be extended upstream of the entrance line to the point at which entering drivers are expected to begin decelerating comfortably. A minimum length of 200 ft (60 m) is recommended for high-speed approaches (24). Exhibit 6-69 provides a diagram of such a splitter island design. The length of the splitter island may differ depending upon the approach speed. The use of flatter and longer tapers in advance of the splitter islands also provides additional visual cues to drivers of a change in roadway environment. The design of the roundabout entry can also provide visual cues to drivers, in that the entry curves from the splitter island block the view of the central island as drivers approach the roundabout.

Extended splitter islands are recommended at rural locations.

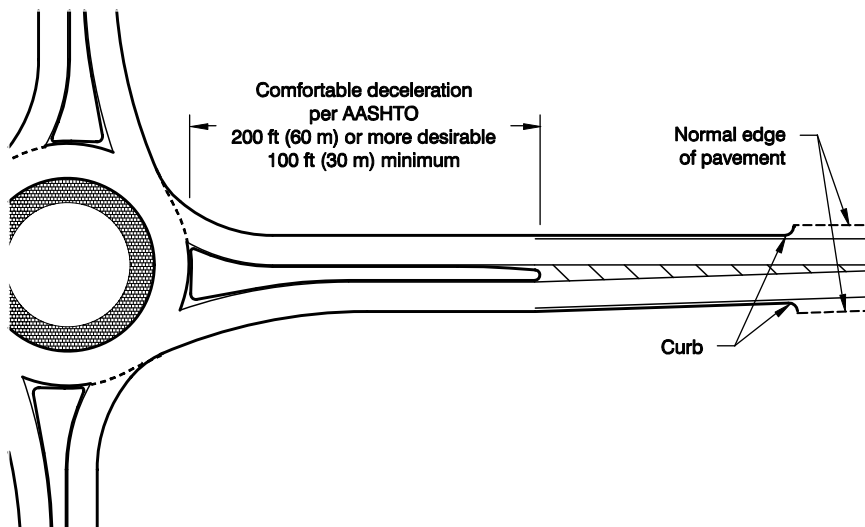

Exhibit 6-69
Extended Splitter
Island Treatment

6.8.5.4 Approach Curves

Roundabouts on high-speed roads [speeds of 50 mph (80 km/h) or higher], despite extra signing efforts, may not be expected by approaching drivers, resulting in erratic behavior and an increase in single-vehicle crashes. Good design encourages drivers to slow down before reaching the roundabout, and this can be most effectively achieved through a combination of geometric design and other design treatments (see Chapter 7). Where approach speeds are high, speed consistency on the approach needs to be addressed to avoid forcing all of the reduction in speed to be completed through the curvature at the roundabout.

A series of progressively sharper curves on a high-speed roundabout approach helps slow traffic to an appropriate entry speed.

The radius of an approach curve (and subsequent vehicular speeds) has a direct impact on the frequency of crashes at a roundabout. A study in Queensland, Australia, has shown that decreasing the radius of an approach curve generally decreases the approaching rear-end vehicle crash rate and the entering-circulating

and exiting–circulating vehicle crash rates (see Chapter 5). On the other hand, decreasing the radius of an approach curve may increase the single-vehicle crash rate on the curve, particularly when the required side-friction for the vehicle to maintain its path is too high. This may encourage drivers to cut across lanes and increase sideswipe crashes on the approach (3).

One method to achieve speed reduction that reduces crashes at the roundabout while minimizing single-vehicle crashes is the use of successive curves on approaches. The Queensland study found that by limiting the change in 85th-percentile speed on successive geometric elements to approximately 12 mph (20 km/h), the crash rate was reduced. It was found that the use of successive reverse curves prior to the roundabout approach curve reduced the single-vehicle crash rate and the sideswipe crash rate on the approach. It is recommended that approach speeds immediately prior to the entry curves of the roundabout be limited to approximately 35 mph (60 km/h) to minimize high-speed rear-end and entering–circulating vehicle crashes.

Exhibit 6-70 shows a typical rural roundabout design with a succession of three curves prior to the entrance line. As shown in the exhibit, these approach curves should be successively smaller radii in order to minimize the reduction in design speed between successive curves. The aforementioned Queensland study found that shifting the approaching roadway laterally by approximately 23 ft (7 m) usually enables adequate curvature to be obtained while keeping the curve lengths to a minimum. If the lateral shift is too small, drivers are more likely to cut into the adjacent lane (3).

Exhibit 6-70
Use of Successive Curves
on High-Speed Approaches

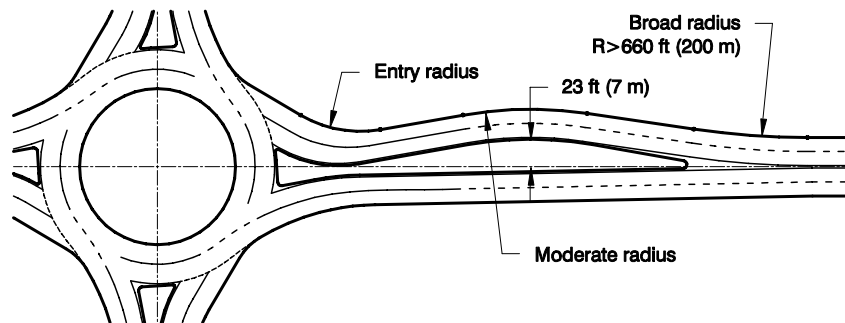

6.8.6 RIGHT-TURN BYPASS LANES

At locations with a high volume of right-turning traffic, a right-turn bypass lane may allow a single-lane roundabout to continue to function acceptably and avoid the need to upgrade to a multilane roundabout. Extending the life of the single-lane roundabout is desirable given the stronger safety performance in comparison to multilane roundabouts due to the smaller size and slower speeds that are achieved.

A right-turn bypass lane (or right-turn slip lane) should be implemented only where needed, especially in urban areas with bicycle and pedestrian activity. The entries and exits of bypass lanes can increase conflicts with bicyclists and with merging on the downstream leg. The generally higher speeds of bypass lanes and

Right-turn bypass lanes can be used in locations with minimal pedestrian and bicycle activity to improve capacity when heavy right-turning traffic exists.

the lower expectation of drivers to stop may increase the risk of collisions with pedestrians. They also introduce additional complexity for pedestrians with visual impairments who are attempting to navigate the intersection. However, in locations with minimal pedestrian and bicycle activity, or where bicycle and pedestrian concerns can be addressed through design, right-turn bypass lanes can be used to improve capacity when heavy right-turning traffic exists.

The provision of a right-turn bypass lane allows right-turning traffic to bypass the roundabout, providing additional capacity for the through and left-turn movements at the approach. Bypass lanes are most beneficial when the demand of an approach exceeds its capacity and a significant proportion of the traffic is turning right. However, it is important to consider the reversal of traffic patterns during the opposite peak time period. In some cases, the use of a right-turn bypass lane can avoid the need to build an additional entry or circulatory lane. To determine if a right-turn bypass lane should be used, the capacity and delay calculations in Chapter 4 should be performed. Right-turn bypass lanes can also be used in locations where the geometry for right turns is too tight to allow trucks to turn within the roundabout. Exhibit 6-71 shows examples of right-turn bypass lanes.



(a) Avon, Colorado



(b) Keene, New Hampshire

Exhibit 6-71
Examples of Right-turn
Bypass Lane

Right-turn bypass lanes can merge back into the main exit roadway or provide a yield-controlled entrance onto the main exit roadway.

There are two design options for right-turn bypass lanes. The first option, shown in Exhibit 6-72 (full bypass), is to carry the bypass lane parallel to the adjacent exit roadway, and then merge it into the main exit lane. Under this option, the bypass lane should be carried alongside the main roadway for a sufficient distance to allow vehicles in the bypass lane and vehicles exiting the roundabout to accelerate to comparable speeds. The bypass lane is then merged at a taper rate according to AASHTO guidelines for the appropriate design speed. The second design option (partial bypass) for a right-turn bypass lane, shown in Exhibit 6-73, is to provide a yield-controlled entrance onto the adjacent exit roadway. The first option provides better

Exhibit 6-72
Configuration of Right-turn Bypass Lane with Acceleration Lane

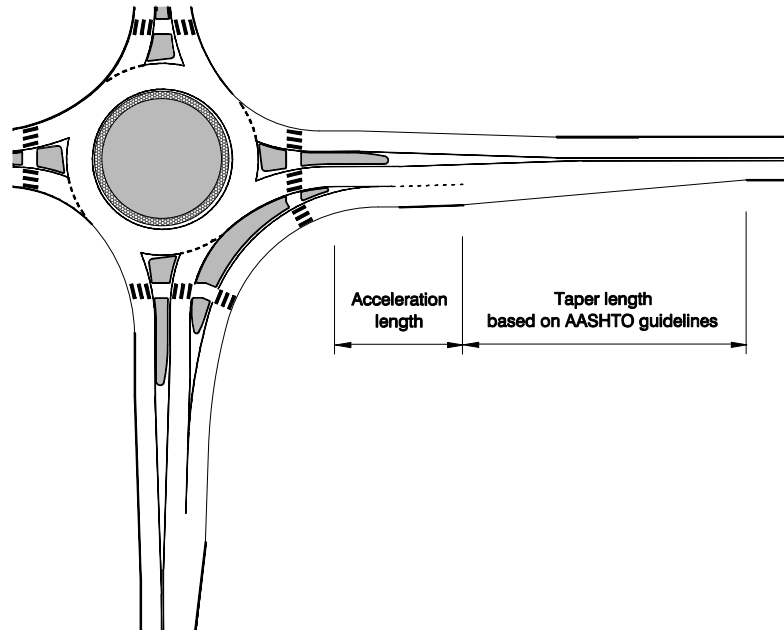
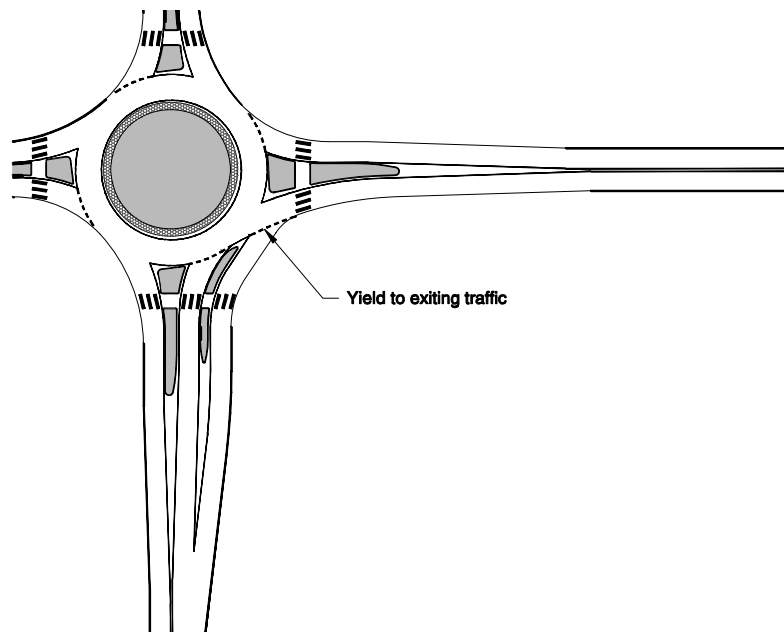

Exhibit 6-73
Configuration of Right-turn Bypass Lane with Yield at Exit Leg



operational performance than the second. However, the second option generally requires less construction and right-of-way than the first.

The option of providing yield control on a bypass lane is generally better for bicyclists and pedestrians and is recommended as the preferred option in urban areas where pedestrians and bicyclists are prevalent. Acceleration lanes can be problematic for bicyclists because they can be caught between two merging streams of motor vehicles. In addition, yield control at the end of a bypass lane tends to slow motorists down, whereas an acceleration lane at the end of a bypass lane tends to promote higher speeds. For both types of bypass lanes, it may sometimes be possible to develop the right-turn-only lane well in advance of the intersection and place a through bicycle lane to the left of the right-turn-only lane, similar to the standard design for conventional intersections. This would make the presence of a right-turn bypass lane less challenging for bicyclists.

The radius of the right-turn bypass lane should not be significantly larger than the radius of the fastest entry path provided at the roundabout. This will ensure that vehicle speeds on the bypass lane are similar to speeds through the roundabout, resulting in safe merging of the two roadways. A small radius also offers greater safety for pedestrians who must cross the right-turn slip lane.

Instead of providing a full bypass lane, another option is to provide a partial bypass by introducing a small vane island (gore striping), as illustrated in Exhibit 6-74. The vane island may be painted or raised, depending upon the dimensions of the islands. Note that additional care must be provided in the design of an entry with two adjacent lanes. Additional design details are provided in Section 6.5.

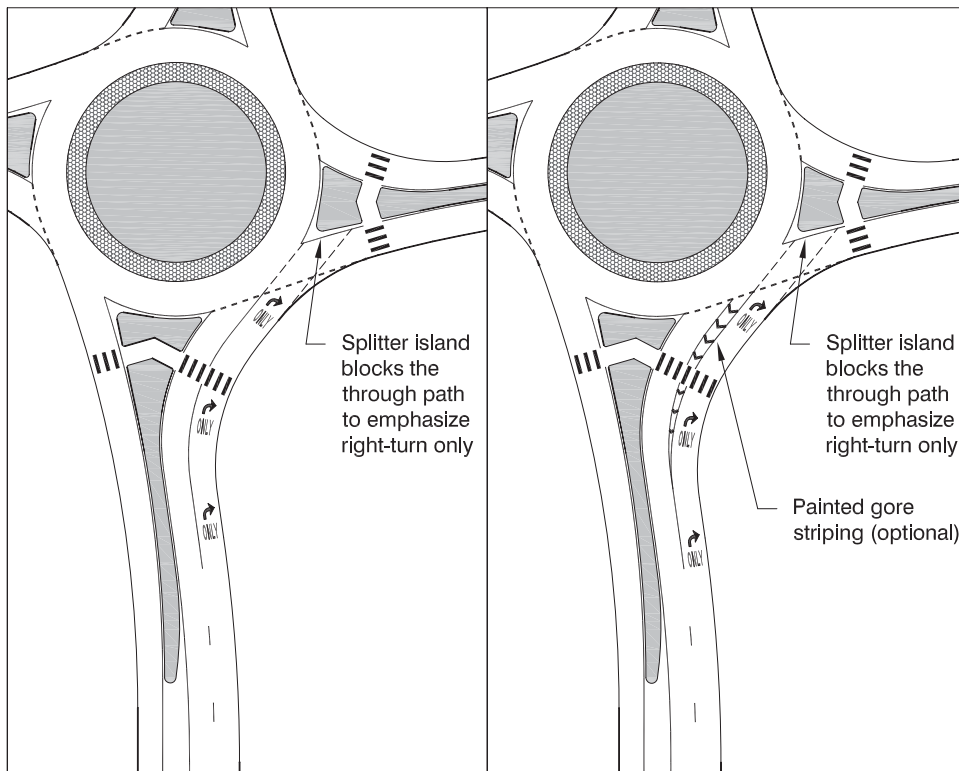

Exhibit 6-74
Exclusive Right-Turn
Lane Designs

6.8.7 VERTICAL CONSIDERATIONS

Components of vertical alignment design for roundabouts include profiles, superelevation, approach grades, and drainage. Vertical design should account for the likelihood of large truck overturning or load shifting, which can sometimes be induced by excessive cross slopes. While these types of incidents account for few personal injury crashes per year, they can produce property damage and create delay and congestion while the intersection is cleared. Many factors can contribute to truck overturning, and both horizontal and vertical design components contribute simultaneously.

6.8.7.1 Profiles

The vertical design of a roundabout begins with the development of the approach roadway and central island profiles. The development of each profile is an iterative process that involves tying the elevations of the approach roadway profiles into a smooth profile around the central island.

Each approach profile should be designed to the point where the approach baseline intersects with the central island. A profile for the central island is then developed that passes through these four points (in the case of a four-legged roundabout). The approach roadway profiles are then readjusted as necessary to meet the central island profile. The shape of the central island profile is generally in the form of a sine curve. Examples of how the profile is developed can be found in Exhibit 6-75, which consist of a sample plan, profiles on each approach, and a profile along the central island, respectively. Note where the four points of the approach roadway baseline are identified on the central island profile.

In addition to the approach and central island profiles, creating an additional profile around the inscribed circle of the roundabout and/or along outer curbs

Exhibit 6-75
Sample Central Island Profile

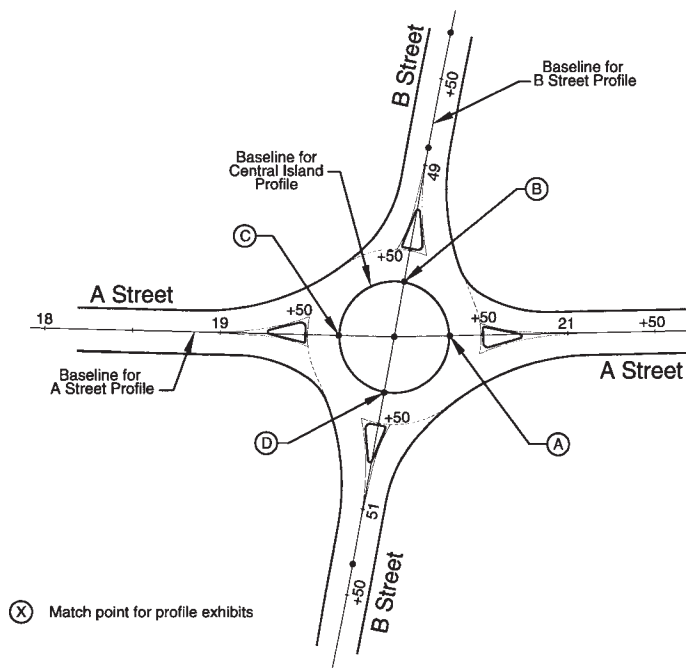
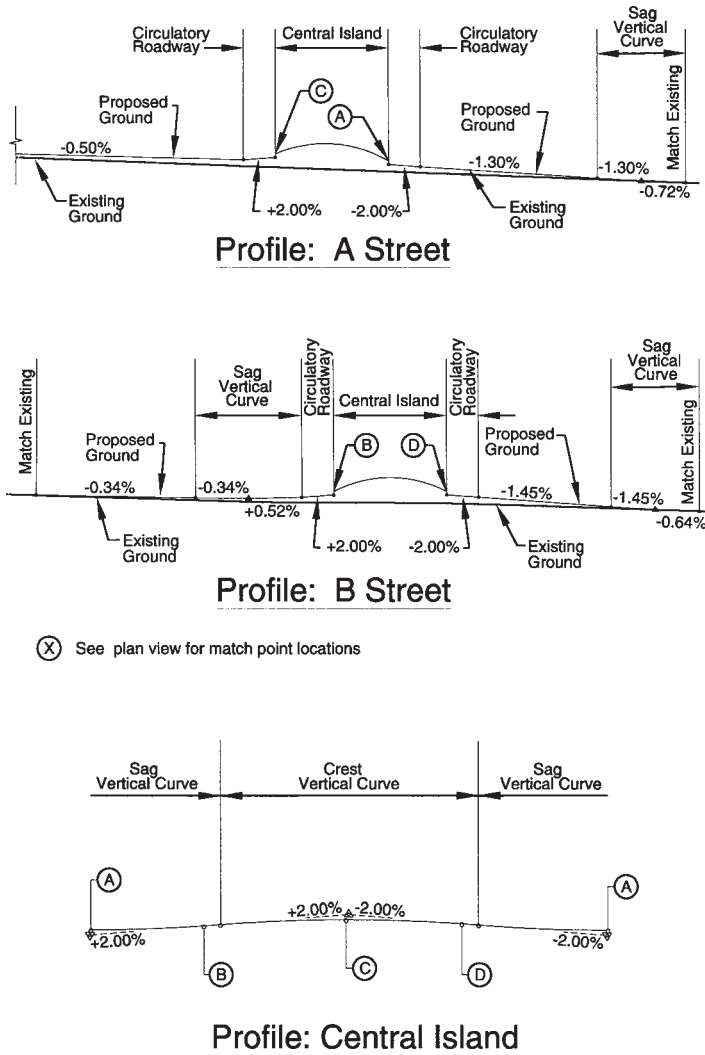

Exhibit 6-75 (cont.)
Sample Central Island Profile



may also be beneficial to the engineer, reviewers, and contractor. The combination of the central island, inscribed circle, and curb profiles allows for quick verification of cross slopes and drainage and provides additional information to contractors for staking out the roundabout.

6.8.7.2 Single-Lane Roundabout Circulatory Roadway

As a general practice, a cross slope of 2% away from the central island should be used for the circulatory roadway on single-lane roundabouts. This technique of sloping outward is recommended for four main reasons:

1. It promotes safety by raising the elevation of the central island and improving its visibility,
2. It promotes lower circulating speeds,
3. It minimizes breaks in the cross slopes of the entrance and exit lanes, and
4. It helps drain surface water to the outside of the roundabout (3, 25).

Negative superelevation (-2%) should generally be used for the circulatory roadway.

The outward cross-slope design means vehicles making through and left-turn movements must negotiate the roundabout at negative superelevation. Excessive negative superelevation can result in an increase in single-vehicle crashes and loss-of-load incidents for trucks, particularly if speeds are high. However, in the intersection environment, drivers will generally expect to travel at slower speeds and will accept the higher side force caused by reasonable adverse superelevation (24).

6.8.7.3 Multilane Roundabout Circulatory Roadway

There are a variety of possible methods for the vertical design of a circulatory roadway within a multilane roundabout. However, two primary methods are typically used: outward sloping and crowned circulatory roadways:

Outward sloping. This is the most common type of vertical design for roundabouts in the United States. The circulatory roadway is graded independently of the rest of each approach, with the circulatory roadway outward draining with a grade of 1.5 to 3%. This is most practical in relatively flat terrain, as hilly terrain may require warping of the profile and possibly an alternative vertical design.

Crowned circulatory roadway. The circulatory roadway is crowned with approximately two-thirds of the width sloping toward the central island and one-third sloping outward. This may alternatively be reversed so that half of the circulatory roadway slopes toward the central island. The maximum recommended cross slope is 2%. Asphalt paving surfaces are recommended under this type of application to produce a smoothed crown shape. This method is primarily intended for consideration at multilane roundabouts. Other vertical design options include:

- *Existing grade lines (non-planar).* It is often desirable to use the existing ground elevation, to the extent possible, to reduce overall changes in vertical profile. At the intersection of two major roadways, this may result in two crown lines crossing one another, with the circulating roadway warping between the crown lines to provide the drainage. This is no different from a major signalized crossroad. However, it can affect driver comfort and lane discipline through the roundabout.
- *Tilted plane.* This method allows the existing road grade line to be maintained. An example is where two roadways currently cross with 2% grade on Road A and 3% grade on Road B. The roundabout should be designed as a plane surface sitting on those two grade lines. The uphill sides of the circulating roadway would have inward slopes of +2% and +3% respectively, with the downhill sections having (negative) crossfalls of -2 and -3%. The section with the steepest crossfall could be modified slightly so that no slope exceeded -2.5%.
- *Folded plane.* The folded plane is a similar concept to the tilted plane, where one direction follows the ruling grade **and** the crown line of one of the roads. The plane of the circulating roadway is folded about the grade line of the road. The ruling grade line can be flat through to about 10%. In a flat area, the two folded planes would typically have a grade differential of 4 to 5%.

6.8.7.4 Truck Aprons

Exhibit 6-76 and Exhibit 6-77 provide typical sections for roundabouts with a truck apron. Where truck aprons are used, the slope of the apron should generally

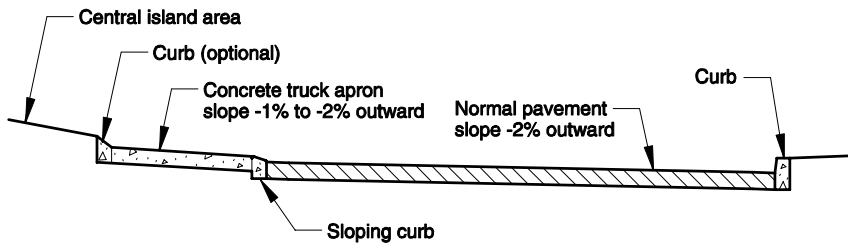

Exhibit 6-76
Typical Section with a
Truck Apron

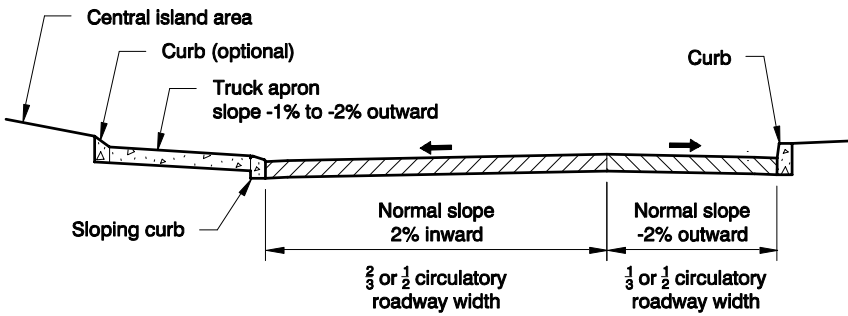

Exhibit 6-77
Typical Section with Crowned
Circulatory Roadway

be no more than 2%; greater slopes may increase the likelihood of loss-of-load incidents. Within the United States, truck aprons are commonly sloped toward the outside of the roundabout. However, some locations have also implemented roundabouts with truck aprons sloped inward (toward the central island) to minimize water shedding across the roadway and to minimize load shifting in trucks. Agencies using this strategy report that additional catch basins were provided along the edge of the central island to collect water and pipe it under the circulatory roadway to connect in with the drainage system along the roundabout periphery.

The vertical design of the truck apron should be reviewed to confirm that there is sufficient clearance for low-boy type trailers, some of which may have only 6 to 8 in. between the roadway surface and bottom of the trailer. The vertical clearance can be reviewed by drawing a chord across the apron in the position where the trailer would sweep across. In some cases the warping of the profile along the circulatory roadway can create high spots that could cause trailers to drag or scrape along the truck apron.

Between the truck apron and the circulatory roadway, a curb is required to accommodate a change in vertical elevation. As shown in Exhibit 6-76 and Exhibit 6-77, the truck apron elevation should be higher than the circulatory roadway to discourage passenger vehicles from using the apron. A variety of different curb shapes are currently used throughout the United States to meet the needs of individual state agency specifications and needs. To discourage passenger car use of the apron, a curb shape with a 2 to 3 in. vertical reveal and then sloped top has historically been common practice. However, concerns regarding truck tires rubbing against the vertical face of the curb and maintenance issues with snow plowing have caused some agencies to use a modified sloping curb type that contains no vertical component. Several examples of these sloping curb shapes are illustrated in Exhibit 6-78.

Exhibit 6-78
Examples of Sloping Truck Apron Curb Shapes Used in the United States

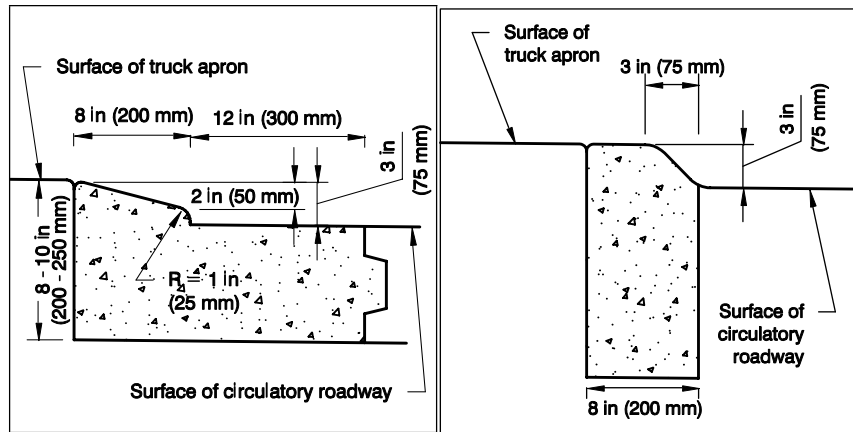

(a) Maryland State Highway Administration (26) (b) Kansas Department of Transportation (27)

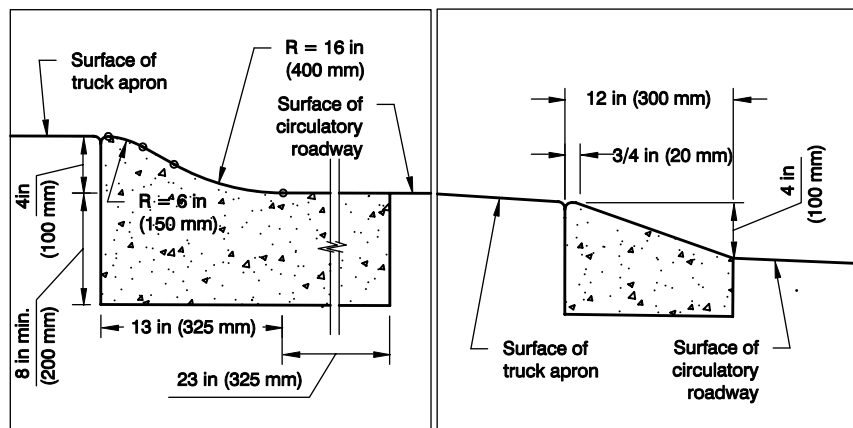

(c) Wisconsin Department of Transportation (28) (d) New York State Department of Transportation (29)

Avoid locating roundabouts in areas where grades through the intersection are greater than 4%.

6.8.7.5 Locating Roundabouts on Grades

It is generally not desirable to place roundabouts in locations where grades through the intersection are greater than 4%, although roundabouts have been installed on grades of 10% or more. Installing roundabouts on roadways with grades lower than 3% is generally not problematic (25). At locations where a constant grade must be maintained through the intersection, the circulatory roadway may be constructed on a constant-slope plane. This means, for instance, that the cross slope may vary from +3% on the high side of the roundabout (sloped toward the central island) to -3% on the low side (sloped outward). Note that the central island cross slopes will pass through a level at a minimum of two locations for roundabouts constructed on a constant grade.

Care is needed when designing roundabouts on steep grades. On approach roadways with grades steeper than -4%, it is more difficult for entering drivers to slow or stop on the approach. At roundabouts on crest vertical curves with steep approaches, a driver's sight lines may be compromised, and the roundabout may violate driver expectancy. However, under the same conditions, other types of at-grade intersections often will not provide better solutions. Therefore, the

roundabout should not necessarily be eliminated from consideration at such a location. Rather, the intersection should be relocated or the vertical profile modified, if possible.

Grades in the vicinity of a roundabout need to reflect the terrain of the area. Roundabouts in hilly areas can be expected to have steeper grades on approaches, departures, and on the circulatory roadway. Steep gradients at entries and exits should be avoided or flattened at the roundabout approaches. Care must be taken by the engineer to ensure that the user is able to safely enter and exit the circulatory roadway. This area requires pavement warping or cross slope transitions to provide an appropriate cross slope transition rate through the entire transition area. Care must also be taken with grading of the vertical profile to ensure that adequate sight distance is provided for the intersection and entry.

Entry grade profiles (approximately two car lengths from the outer edge of the circulatory roadway) should not exceed 3%, with 2% being the desirable maximum. It is desirable to match the exit grades and the entry grades; however, the exit grade may be steeper but should not exceed 4%. Adjustments to the circulatory roadway cross slope may be required to meet these criteria but should be balanced with the effects on the circulatory roadway (7).

6.8.7.6 Drainage

With the circulatory roadway sloping away from the central island, inlets will generally be placed on the outer curb line of the roundabout. Inlets can usually be avoided on the central island for a roundabout designed on a constant grade through an intersection. As with any intersection, care should be taken to ensure that low points and inlets are placed upstream of crosswalks.

6.8.8 MATERIALS AND DESIGN DETAILS

6.8.8.1 Curb Types

A generally vertically faced curb, typically 6 in. (150 mm) high, is recommended around the outside of the roundabout, the central island, and the splitter islands since one of the important elements of these features is to force deflection in vehicles traveling through the roundabout. If the curb is considered to be traversable by drivers, this effect may be lessened. A vertically faced curb on the approach and in the splitter island also provides better protection for the pedestrian. However, most roundabouts must also be designed to accommodate large trucks. Additional detail on curb types around the edge of the truck apron is provided in Section 6.8.7.4.

6.8.8.2 Circulatory Roadway Pavement Type

Asphalt concrete and Portland cement concrete pavements have been used for construction of roundabouts throughout the United States. The majority of roundabouts, both domestic and internationally, use asphalt concrete paving. The decision of whether to use asphalt concrete or Portland cement concrete will depend on local preferences and the pavement type of the approach roadways. Portland cement concrete generally has a longer design life and holds up better

under truck traffic. However, few agencies have reported problems with rutting on well-constructed asphalt concrete pavement.

Constructability is also a consideration in choosing pavement type. Construction of a roundabout under traffic is typically easier when using asphalt concrete pavement. It is also typically easier to construct a smooth crown line using asphalt concrete if the circulatory roadway is crowned.

If Portland cement concrete pavement is used, joint patterns should be concentric and radial to the circulating roadway within the roundabout. Ideally the joints should not conflict with pavement markings within the roundabout, although concrete panel sizes may control this. On multilane roundabouts, circumferential joints within the circulating roadway should follow the lane edges to the extent practical. Specifications for jointing and dowel details tend to vary by location, and the local jurisdiction should be consulted for requirements. Additional information and publications regarding jointing are available from the American Concrete Paving Association (30). Example jointing plans are shown in Exhibit 6-79 and Exhibit 6-80.

Exhibit 6-79
Example Concrete Jointing
Patterns

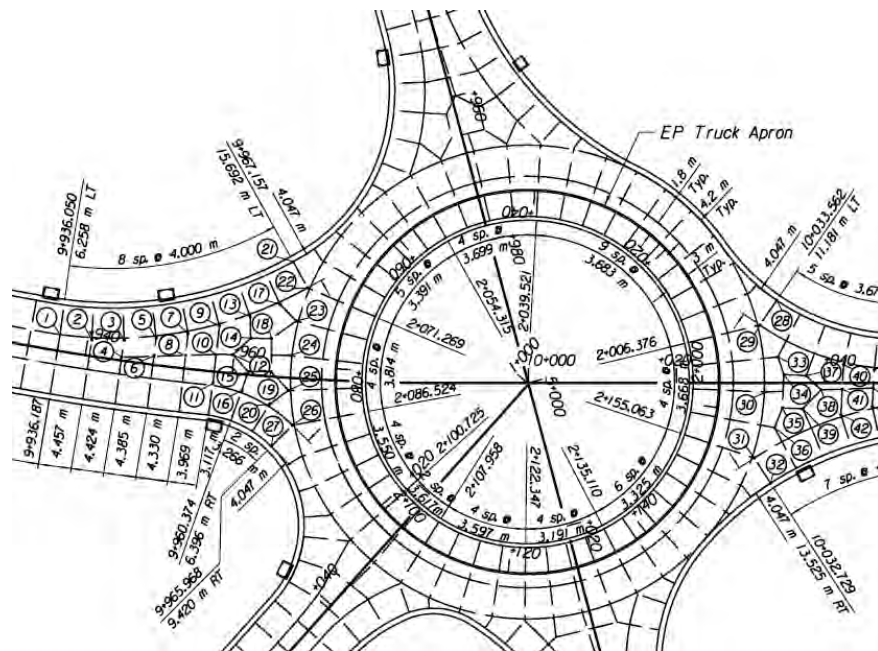

Source: Kansas Department of Transportation

Cracking has been found to be a problem in some Portland cement concrete roundabouts, particularly around the outside of the circulating roadway in the vicinity of the outside curbs and splitter islands, so special care needs to be taken to provide the necessary relief. One possible option is to isolate the circulating roadway with an expansion joint and construct special monolithic sections in key areas.

Exhibit 6-80
Example Concrete Jointing
Patterns

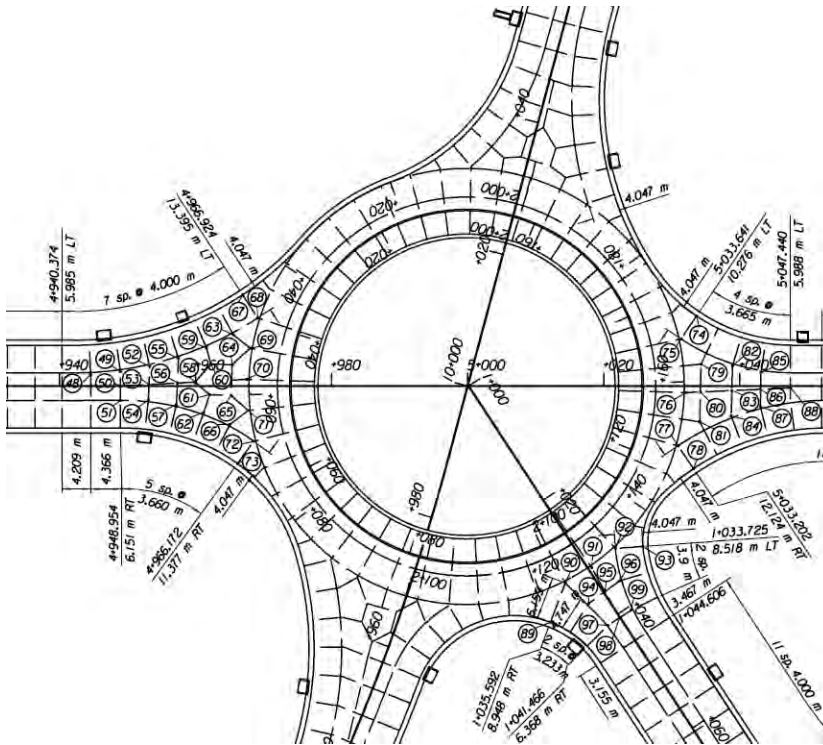

Source: Kansas Department of Transportation

6.8.8.3 Truck Apron Material

For the truck apron, concrete pavement or concrete with a brick paver surface is commonly used. Other options include using large [4 in (100 mm)] river rocks embedded in concrete that can be traversed by trucks but are uncomfortable for smaller vehicles or pedestrians. A geogrid-type material can also be used to provide a more landscaped appearance but hold up to occasional encroachment by large trucks. The material used for the truck apron should be selected so as to not look like the sidewalk. This will help to keep pedestrians off the truck apron and central island. If the truck apron is constructed under traffic, high early strength concrete should be used to minimize the amount of down time for the intersection.

6.8.8.4 Material Selection

Visibility of the various design elements through variations in material, color, and/or texture should be considered in the selection of materials for splitter island curbs and outside curbs, pavement, and truck apron. Curbs should be of a material or color that contrasts with the pavement material to provide adequate visibility to approaching drivers. For example, the use of standard concrete curbs adjacent to concrete pavement may not allow a driver to easily discern the location of the curbs and the geometric curvature of the entry to the roundabout on approach.

The use of enhanced delineation adjacent to the curb (by use of additional markings, reflectors, and other markers) may also be applied where contrasting materials cannot be used. However, these types of supplemental delineators are typically less desirable due to maintenance requirements.

6.9 CLOSELY SPACED ROUNDABOUTS

It is sometimes desirable to consider the operation of two or more roundabouts in close proximity to each other. In these cases, the expected queue length at each roundabout becomes important. Exhibit 6-81(a) presents an example of closely spaced T-intersections. The engineer should compute the 95th-percentile queues for each approach to check that sufficient queuing space is provided for vehicles between the roundabouts. If there is insufficient space, then drivers will occasionally queue into the upstream roundabout and may cause it to lock.

Closely spaced roundabouts may have a traffic calming effect on the major road.

Closely spaced roundabouts may improve safety by calming the traffic on the major road. Drivers may be reluctant to accelerate to the expected speed on the arterial if they are also required to slow again for the next close roundabout. This may benefit nearby residents.

Roundabouts may also provide benefit for other closely spaced intersections. Short delay and queuing for vehicles at roundabouts allow for tighter spacing of

Exhibit 6-81
Examples of Closely Spaced
Roundabouts



(a) France



(b) Livingston County, Michigan

intersections without providing a significant operational detriment to the other intersection, provided that adequate capacity is available at both intersections. Exhibit 6-81(b) illustrates two closely spaced roundabouts at an interchange ramp and nearby frontage road. The two roundabouts work together as a system to effectively serve the traffic demands. Due care must be given to a system of roundabouts with this complexity to ensure that the design objectives are met, that each approach leg has sufficient capacity, and that the lane numbers and arrangements work together to allow a driver to intuitively navigate the intersection without lane changes or weaving.

6.10 INTERCHANGES

Freeway ramp junctions with arterial roads are potential candidates for use of roundabouts at the ramp terminals. This is especially so if the subject interchange typically has a high proportion of left-turn flows from the off-ramps and to the on-ramps during certain peak periods, combined with limited queue storage space on the bridge crossing, off-ramps, or arterial approaches. In such circumstances, roundabouts operating within their capacity are particularly suited to solving these problems when compared with other forms of intersection control.

6.10.1 DIAMOND INTERCHANGE

The most common type of interchange that incorporates roundabouts is a standard diamond interchange with a roundabout at each side of the freeway (see Exhibit 6-82 and Exhibit 6-83). A bridge is used for the crossroad over the freeway or for a freeway to cross over the minor road. Again, two bridges may be used when the freeway crosses over the minor road.

The use of two roundabouts at the ramp terminals provides some advantages over the single-point interchange. The use of two roundabouts offers flexibility in locating the ramp terminal intersections to minimize affects on retaining wall structures and improve the ramp geometry approaching the roundabout. It may also provide greater flexibility for adding lanes to the roundabout at a later date to increase the interchange capacity.

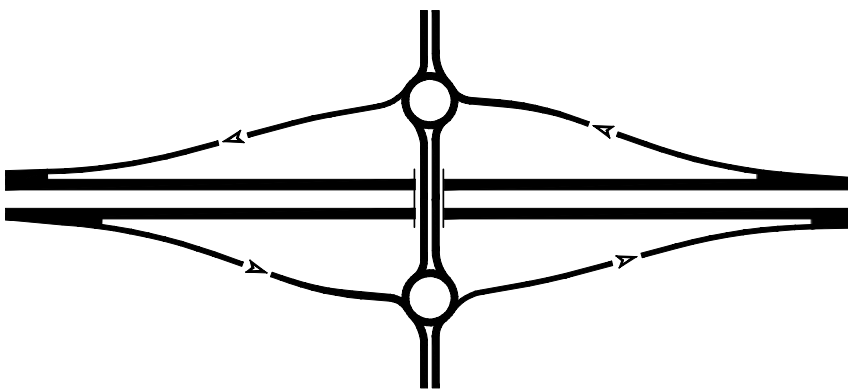

Source: Adapted from Arizona Department of Transportation (31)

Exhibit 6-82
Conceptual Diamond
Interchange

Exhibit 6-83
Conceptual Diamond
Interchange with
Frontage Roads

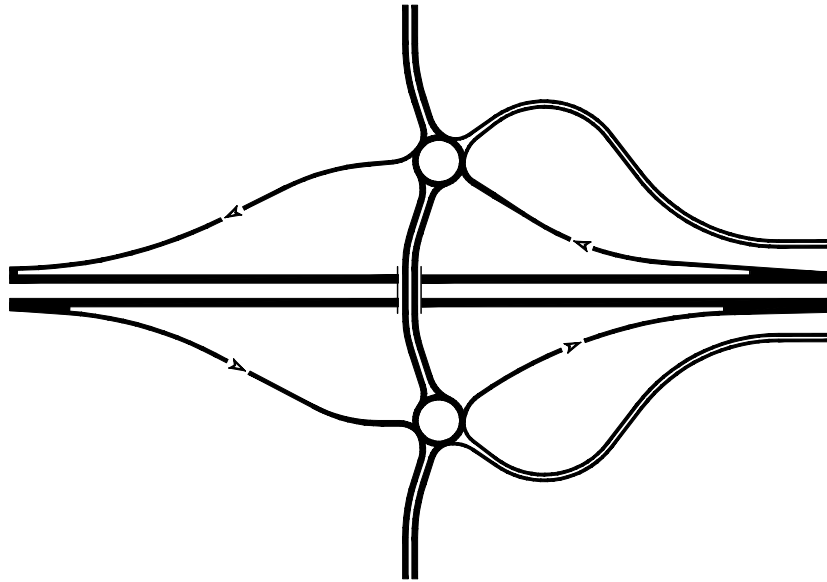

Source: Arizona Department of Transportation (31)

Diamond interchanges using roundabouts at the terminals have been successfully used to defer the need for bridge widening.

This interchange form has been used successfully in some cases to defer the need to widen bridges. Unlike signalized ramps that may require exclusive left-turn lanes across the bridge and extra queue storage, this type of roundabout interchange exhibits very little queuing between the intersections since these movements are almost unopposed. Therefore, the approach lanes across the bridge can be minimized.

The actual roundabouts can have two different shapes or configurations. The first configuration is a conventional one with circular central islands. This type of configuration is recommended when it is desirable to allow U-turns at each roundabout or to provide access to legs other than the cross street and ramps. An example is shown in Exhibit 6-84.

Exhibit 6-84
Example of Interchange with
Circular Central Islands



Wisconsin

The second configuration uses raindrop-shaped central islands that preclude some turns at the roundabout; examples are shown in Exhibit 6-85 and Exhibit 6-86. This configuration is best used when ramps (and not frontage roads) intersect at the roundabout. A raindrop central island can be considered to be a circular shape blocked at one end. In this configuration, a driver wanting to make a U-turn has to drive around both raindrop-shaped central islands. The raindrop configuration has an advantage in that it makes wrong-way turns into the off-ramps more difficult and removes excess pavement on the circulatory roadway that would only service U-turn maneuvers. In doing so, it also removes the yielding condition on the leg coming from the upstream roundabout, which virtually eliminates the likelihood of queuing between the ramp terminals. On the other hand, the lack of operational consistency with other roundabout entries (where one entry is not required to yield) is one of the primary concerns causing some engineers to advocate the use of a conventional roundabout shape over the raindrop shape. In addition, if a raindrop-shaped roundabout is designed poorly, drivers may be traveling faster than they should to negotiate the next roundabout safely.

Raindrop central islands make wrong-way movements more difficult, but require navigating two roundabouts to make a U-turn.



Carmel, Indiana

Exhibit 6-85
Example of a Compact Interchange with Raindrop-Shaped Central Islands



Avon, Colorado

Exhibit 6-86
Example of Interchange with Raindrop-Shaped Central Islands

6.10.2 SINGLE-POINT DIAMOND INTERCHANGE

Another type of diamond interchange is a single-point diamond interchange. This incorporates a single large-diameter roundabout centered over or under a freeway. The ramps connect directly into the roundabout, as do the legs from the crossroad. This is illustrated in Exhibit 6-87.

Exhibit 6-87
Single-Point Diamond Interchange with One Roundabout

The freeway may either go over or under the circulatory roadway.

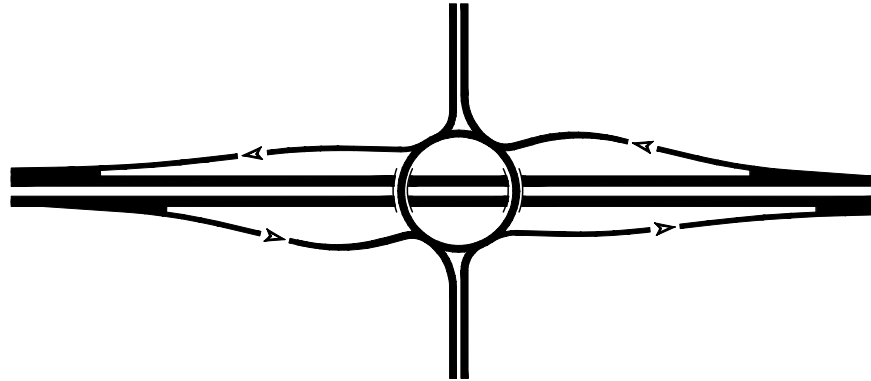

Source: Arizona Department of Transportation (31)

This type of interchange requires two bridges. If the roundabout is above the freeway as shown in Exhibit 6-87, then the bridges may be curved. Alternatively, if the freeway goes over the roundabout, then four shorter bridges or two longer bridges may be required, as shown in Exhibit 6-88. The number of bridges will depend on the optimum span of the type of structure compared with the inscribed diameter of the roundabout island and on whether the one bridge is used for both freeway directions or whether there is one bridge for each direction. The road cross section will also influence the design decision.

Exhibit 6-88
Example Split Diamond Single-Point Interchange



Newton, Kansas

6.11 ACCESS MANAGEMENT

Access points near an intersection or along an arterial create additional conflicts within the roadway system that affect operations and safety. Managing access points can improve the overall effectiveness of the system by streamlining the roadway operations and reducing the number of conflicts. Roundabouts can provide a useful tool within an access management program to provide U-turn opportunities at the intersections, thereby allowing for a reduction of full access points along the roadway segment. However, within the vicinity of an individual roundabout intersection, property access must also be carefully evaluated.

Access management at roundabouts follows many of the principles used for access management at conventional intersections. For public and private access points near a roundabout, two scenarios commonly occur:

- Access into the roundabout itself or
- Access near the roundabout.

6.11.1 ACCESS INTO THE ROUNDABOUT

It is preferable to avoid locating driveways where they must take direct access to a roundabout. Driveways introduce conflicts into the circulatory roadway, including acceleration and deceleration. Traditional driveway designs do not discourage wrong way movements as a splitter island does.

Nonetheless, site constraints sometimes make it necessary to consider providing direct access into a roundabout. Exhibit 6-89 shows examples where one or two residential houses have been provided direct access into a roundabout. These driveways have been designed with traditional concrete driveway aprons to provide a clear visual and tactile indication that these are private driveways not to be confused with public roadways.

For a driveway to be located where it takes direct access to the circulatory roadway of a roundabout, it should satisfy the following criteria:

- No alternative access point is reasonable.
- Traffic volumes are sufficiently low to make the likelihood of errant vehicle behavior minimal. Driveways carrying the trip generation associated with a very small number of single-family houses are typically acceptable; driveways with higher traffic volumes should be designed as a regular approach with a splitter island. In addition, if a high proportion of unfamiliar drivers are expected at the driveway, the engineer should consider providing more positive guidance.
- The driveway design should enable vehicles to exit facing forward with a hammerhead design or other area on-site where vehicles can turn around. Driveways that only allow backing maneuvers into the roundabout should be discouraged in all but very low-volume environments.
- The driveway design should enable proper intersection sight distance from the driveway location and adequate stopping sight distance for vehicles approaching the driveway traveling along the primary roadway.

Exhibit 6-89
Example of Residential
Driveways into Circulatory
Roadway



(a) Santa Barbara, California



(b) Voorheesville, New York

6.11.2 ACCESS NEAR THE ROUNDABOUT

Public and private access points near a roundabout often have restricted operations due to the channelization of the roundabout. Driveways between the crosswalk and entrance line complicate the pedestrian ramp treatments and introduce conflicts in an area critical to operations of the roundabout. Exhibit 6-90 shows examples of driveway challenges of this type. Driveways blocked by the splitter island will be restricted to right-in/right-out operation and are best avoided altogether unless the impact is expected to be minimal and/or no reasonable alternatives are available.

The ability to provide an access point that allows all ingress and egress movements (hereafter referred to as *full access*) is governed by a number of factors:

- *The capacity of the minor movements at the access point.* A standard unsignalized intersection capacity analysis should be performed to assess the operational effectiveness of an access point with full access. Unlike the platooned flow typically downstream of a signalized intersection, traffic passing in front of an access point downstream of a roundabout will be more randomly distributed. As a result, an access point downstream of a roundabout may have less capacity and higher delay than one



(a) Driveway between crosswalk and roundabout (Bend, Oregon)



(b) Driveway aligned with crosswalk (Sammamish, Washington)



(c) Driveway reconfiguration (Clearwater, Florida)

Exhibit 6-90
Example of Driveway
Challenges near Roundabout

downstream of a traffic signal. Queuing from nearby intersections (the roundabout or others nearby) should be checked to see if the operation of the access point will be affected.

- *The need to provide left-turn storage on the major street to serve the access point.* For all but low-volume driveways it is often desirable to provide separate left-turn storage for access points downstream of a roundabout to minimize the likelihood that a left-turning vehicle will block the major street traffic flow. If quantification is desired, a probability analysis can be used to determine the likelihood of an impeding left-turning vehicle, and a queuing analysis can be used to determine the length of the queue behind the impeding left-turning vehicle. If the number of left-turning vehicles is sufficiently small and/or the distance between the access point and the roundabout is sufficiently large, a left-turn pocket may not be necessary.
- *The available space between the access point and the roundabout.* Exhibit 6-91 presents a figure showing typical dimensions associated with a roundabout and left-turn storage for a downstream minor street. As the figure demonstrates, a minimum distance is required to provide adequate roundabout splitter island design and left-turn pocket channelization. In addition, access is restricted along the entire length of the splitter island and left-turn pocket channelization.

Exhibit 6-91
Typical Dimensions for
Left-Turn Access near
Roundabouts

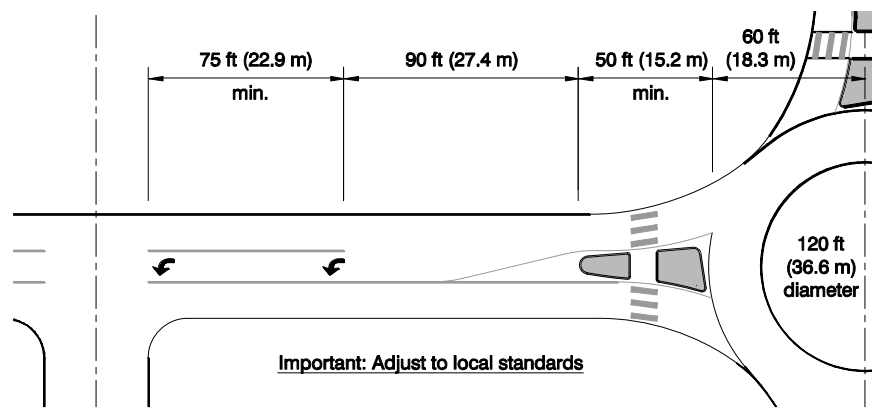

- *Sight distance needs.* A driver at the access point should have proper intersection sight distance and should be visible when approaching or departing the roundabout, as applicable.

6.12 STAGING OF IMPROVEMENTS

When projected traffic volumes indicate that a multilane roundabout is required for future year conditions, engineers should evaluate the duration of time that a single-lane roundabout would operate acceptably before requiring

additional lanes. Where a single-lane roundabout will be sufficient for much of its design life, engineers should evaluate whether it is best to first construct a single-lane roundabout until traffic volumes dictate the need for expansion to a multi-lane roundabout. One reason to stage the construction of a multi-lane roundabout is that future traffic predictions may never materialize due to the significant number of assumptions that must be made when developing volume estimates for a 20- or 30-year design horizon.

Single-lane roundabouts are generally simpler for motorists to learn and are more easily accepted in new locations. This, combined with fewer vehicle conflicts, should result in a better overall crash experience and allow for a smooth transition into the ultimate multi-lane build-out of the intersection. Single-lane roundabouts introduce fewer conflicts to pedestrians and provide increased safety benefits and usability to pedestrians by minimizing the crossing distance and limiting their exposure time to vehicles while crossing an approach. Single-lane roundabouts are also safer and easier for bicyclists to use, making it more likely that cyclists will be able to use the roundabout like other vehicles.

When considering an interim single-lane roundabout, the engineer should evaluate the right-of-way and geometric needs for both the single-lane and multi-lane configurations. Consideration should also be given to the future construction staging for the additional lanes. Discussed below are two ways to expand from a single-lane to a double-lane roundabout.

6.12.1 EXPANSION TO THE OUTSIDE

Expansion to the outside involves adding any necessary lanes for the ultimate configuration to the outside of the interim roundabout configuration, with the central island and splitter islands remaining the same in both interim and ultimate configurations. Assuming that the right-of-way was purchased for the ultimate design, the interim sidewalks and landscaping could also be constructed in their ultimate location.

When using this option, care should be taken to provide adequate geometric features, including entry and splitter island design, to ensure that speed reduction and adequate natural paths will be provided at build-out. In preparing for this type of construction staging, it may be appropriate to initially design the roundabout for the ultimate double-lane condition to ensure adequate geometry and then remove the outside lanes from the design to form the initial single-lane roundabout. It is also helpful to evaluate the ultimate footprint of the roundabout to reserve right-of-way to accommodate the future widening.

This configuration has the potential to be less of a disruption to vehicular traffic during the expansion since the majority of the improvements are on the outside of the roadway. Drainage structures will typically need to be relocated, and the new outside curb lines will need to be constructed first. The original curb line is then demolished and replaced with pavement. The original pavement markings should be ground off and final markings and signs should be placed before the additional lanes of traffic are opened for use. In locations where concrete pavement

is used, grinding off of the pavement markings may leave a permanent mark on the roadway surface that may be confusing to drivers. Therefore, particular care should be taken in locating the markings in the interim configuration where concrete paving is used to minimize the need for relocation of the markings in the ultimate configuration.

6.12.2 EXPANSION TO THE INSIDE

Expansion to the inside involves adding any necessary lanes for the ultimate configuration to the inside of the interim roundabout configuration, with the outer curbs and inscribed circle diameter remaining the same in both interim and ultimate configurations. This allows the engineer to set the outer limits of the intersection during the initial construction and limits the future construction impacts to surrounding properties during widening, as sidewalks and outer curb lines will not typically require adjustment.

As with the other option, the roundabout is initially designed for the ultimate multilane configuration. However, the modification to a single-lane design is done by providing wide splitter islands and an enlarged central island that occupy the space required for the inside travel lanes. Future expansion to the multilane roundabout is accomplished by reducing the width of the splitter islands and widening on the inside of the existing travel lanes. Typically, the splitter islands, central island curbing, and truck apron would require replacement. This type of expansion is illustrated in Exhibit 6-92.

This process typically requires short-term lane closures and therefore may be best accomplished by working on one approach at a time and implementing localized detours for the approach that is undergoing demolition. The remainder of the intersection can continue to operate normally. Additionally, if demolition is staged from the entry lanes of the intersection, the exit on the leg where demolition is occurring may be able to remain open. Once the old splitter island is removed, work on forming and pouring concrete for the new splitter island can be accomplished from the new inside lane developed as part of the initial demolition. This may allow for the original outside entry lane to be re-opened to traffic, subject to flagging or other necessary traffic control. Once the new splitter island has been constructed and the additional roadway pavement is placed for an approach, the new inside lanes should remain coned off until the remaining approaches have been completed and the final markings and signing have been placed for the full intersection.

In cases where the interim configuration of the roundabout is expected to be in place for a limited time before the ultimate configuration is implemented, it may be possible to construct the splitter island in its ultimate location with a narrower width and add supplemental pavement markings to channelize the single-lane approach width for the interim configuration. This would minimize the reconstruction of the splitter island for the future configuration; however, the striped portion of the splitter island would require ongoing maintenance and may not be as effective at providing vehicle deflection at the roundabout entrance.

Exhibit 6-92
Staged Multilane Roundabout

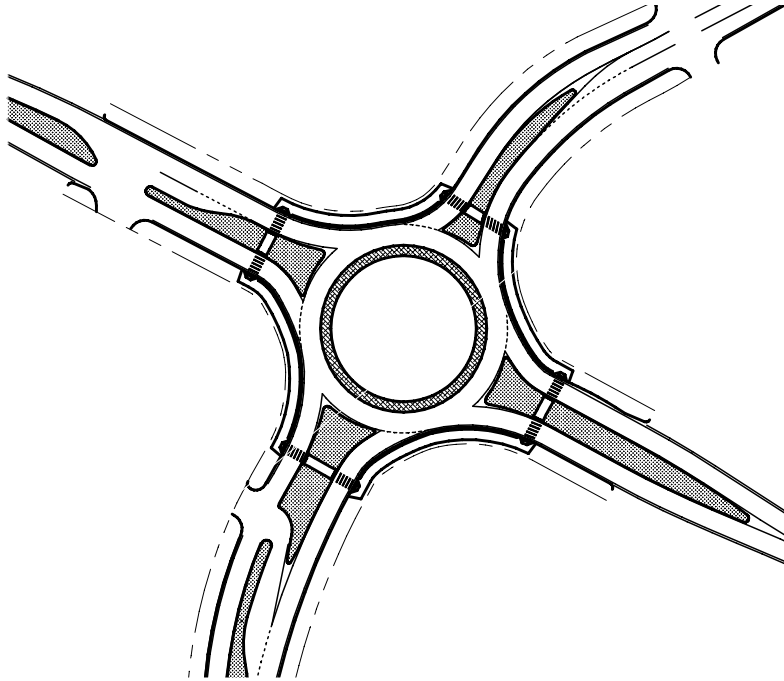

(a) Staged Multilane Roundabout: Interim Configuration

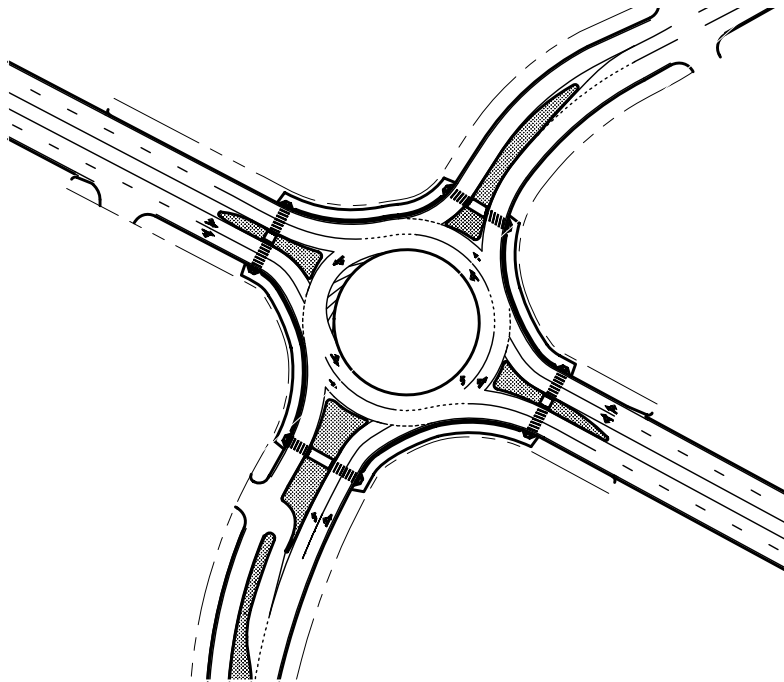

(b) Staged Multilane Roundabout: Ultimate Configuration