



Bridge Design - Steel Plate Girders

Course Number: CE-02-407

PDH: 9

Approved for: AK, AL, AR, FL, GA, IA, IL, IN, KS, KY, LA, MD, ME, MI, MN, MO, MS, MT, NC, ND, NE, NH, NJ, NM, NV, NY, OH, OK, OR, PA, SC, SD, TN, TX, UT, VA, VT, WI, WV, and WY

New Jersey Professional Competency Approval #24GP00025600

North Carolina Approved Sponsor #S-0695

Maryland Approved Provider of Continuing Professional Competency

Indiana Continuing Education Provider #CE21800088

Florida Provider #0009553 License #868

NYSED Sponsor #274

This document is the course text. You may review this material at your leisure before or after you purchase the course. In order to obtain credit for this course, complete the following steps:

- 1) Log in to My Account and purchase the course. If you don't have an account, go to New User to create an account.
- 2) After the course has been purchased, review the technical material and then complete the quiz at your convenience.
- 3) A Certificate of Completion is available once you pass the exam (70% or greater). If a passing grade is not obtained, you may take the quiz as many times as necessary until a passing grade is obtained (up to one year from the purchase date).

If you have any questions or technical difficulties, please call (508) 298-4787 or email us at admin@PDH-Pro.com.



Division of Engineering Services

BRIDGE DESIGN PRACTICE

4th Edition

2015



State of California
Department of Transportation

CHAPTER 9

STEEL PLATE GIRDERS

TABLE OF CONTENTS

9.1	INTRODUCTION.....	1
9.2	STRUCTURAL MATERIALS.....	1
	9.2.1 Structural Steel.....	1
	9.2.2 Concrete.....	2
9.3	SPAN AND FRAMING ARRANGEMENT.....	2
	9.3.1 Span Configuration.....	2
	9.3.2 Girder Spacing.....	2
	9.3.3 Diaphragms and Cross Frames.....	3
	9.3.4 Lateral Bracing.....	5
	9.3.5 Field Splice Locations.....	5
	9.3.6 Expansion Joints and Hinges.....	5
9.4	SECTION PROPORTION.....	6
	9.4.1 Depth to Span Ratios.....	6
	9.4.2 Webs.....	6
	9.4.3 Flanges.....	7
	9.4.4 Stiffeners.....	8
9.5	STRUCTURAL MODELING AND ANALYSIS.....	8
9.6	DESIGN LIMIT STATES AND PROCEDURES.....	9
	9.6.1 Design Limit States.....	9
	9.6.2 Design Procedure.....	9
9.7	DESIGN EXAMPLE - THREE-SPAN CONTINUOUS COMPOSITE PLATE GIRDER BRIDGE.....	11
	9.7.1 Steel Girder Bridge Data.....	11
	9.7.2 Design Requirements.....	12
	9.7.3 Select Girder Layout and Sections.....	13
	9.7.4 Perform Load and Structural Analysis.....	18
	9.7.5 Calculate Live Load Distribution Factors.....	22
	9.7.6 Determine Load and Resistance Factors and Load Combinations.....	25
	9.7.7 Calculate Factored Moments and Shears – Strength Limit States.....	26



9.7.8	Calculate Factored Moments and Shears – Fatigue Limit States	28
9.7.9	Calculate Factored Moments – Service Limit State II	30
9.7.10	Design Composite Section in Positive Moment Region at 0.5 Point of Span 2..	31
9.7.11	Design Noncomposite Section in Negative Moment Region at Bent 3	45
9.7.12	Design Shear Connectors for Span 2.....	64
9.7.13	Design Bearing Stiffeners at Bent 3	67
9.7.14	Design Intermediate Cross Frames.....	70
9.7.15	Design Bolted Field Splices	77
9.7.16	Calculate Deflection and Camber.....	98
9.7.17	Identify and Designate Steel Bridge Members and Components.....	100
NOTATION	101
REFERENCES	105

CHAPTER 9

STEEL PLATE GIRDERS

9.1 INTRODUCTION

Girder bridges are structurally the simplest and the most commonly used on short to medium span bridges. Figure 9.1-1 shows the Central Viaduct in San Francisco. Steel I-section is the simplest and most effective solid section for resisting bending and shear. In this chapter straight composite steel-concrete plate girder bridges are discussed. Design considerations for span and framing arrangement, and section proportion are presented. A design example of the three span continuous composite plate girder bridge is given to illustrate the design procedure. For a more detailed discussion, reference may be made to texts by Chen and Duan (2014), Baker and Puckett (2013), FHWA (2012), and Taly (2014).



Figure 9.1-1 Central Viaduct in San Francisco

9.2 STRUCTURAL MATERIALS

9.2.1 Structural Steel

ASTM A 709 or AASHTO M 270 (Grades 36, 50, 50S, 50W, HPS 50W, HPS 70W and 100/100W) structural steels are commonly used for bridge structures. Chapter 6 provides a more detailed discussion.

9.2.2 Concrete

Concrete with 28-day compressive strength $f'_c = 3.6$ ksi is commonly used in concrete deck slab construction. Caltrans MTD 10-20 (Caltrans, 2008) provides concrete deck slab thickness and reinforcement. The transformed area of concrete is used to calculate the composite section properties. For normal weight concrete of $f'_c = 3.6$ ksi, the ratio of the modulus of elasticity of steel to that of concrete, $n = E/E_c = 8$ is recommended by AASHTO (2012).

For unshored construction, the modular ratio n is used for transient loads applied to the short-term composite sections, and the modular ratio $3n$ is used for permanent loads applied to the long-term composite sections.

9.3 SPAN AND FRAMING ARRANGEMENT

9.3.1 Span Configuration

Span configuration plays an important role in the efficient and cost-effective use of steel. For cases where pier locations are flexible, designers should optimize the span arrangement. Two-span continuous girders/beams are not the most efficient system because of high negative moments. Three- and four-span continuous girders are preferable, but may not always be possible. For multi-span continuous girders, a good span arrangement is to have the end span lengths approximately 70 to 80 percent of the interior span lengths. Equal interior span arrangements are also relatively economical. A span configuration with uplift due to live load plus impact should be avoided.

The use of simply supported girders under construction load and continuous girders through steel reinforcement for live load can be an economical framing method (Azizinamini, 2007). This type of framing presents possible advantages over continuous beam designs by eliminating costly splices and heavy lifts during girder erection. The potential drawbacks are that more section depth may be required and the weight of steel per unit deck area may be higher. This framing method needs to be investigated on a case-by-case basis to determine whether it can be economically advantageous.

When simply supported span configurations are used, special attention should be given to seismic performance detailing.

9.3.2 Girder Spacing

As a general rule, the most economical superstructure design can be achieved using girder spacing within an 11 ft. to 14 ft. range. For spans less than 140 ft., 10 ft. to 12 ft. spacing is preferred. For spans greater than 140 ft., 11 ft. to 14 ft. spacing is recommended. The use of metal deck form panels will limit the spacing to about 16 ft. Girder spacings over 16 ft. may require a transversely post-tensioned deck system. Parallel girder layout should be used wherever possible.

9.3.3 Diaphragms and Cross Frames

The terms diaphragm and cross frame are synonymous. Figure 9.3-1 shows typical types of diaphragms and cross frames used in I-shaped plate girder and rolled beam spans. The K-frames and X-frames usually include a top strut as shown in Figure 9.3-1. Intermediate cross frames provide bracing against lateral torsional buckling of compression flanges during erection and deck concrete placement, and for all loading stages in negative flexure regions. They also provide lateral bracing for wind loads. End cross frames or diaphragms at piers and abutments are provided to transmit lateral wind loads and seismic loads to the bearings.

9.3.3.1 Spacing

Arbitrary 25 ft. spacing limit for diaphragms and cross frames was specified in the *AASHTO Standard Design Specifications* (AASHTO, 2002) and the *Caltrans Bridge Design Specifications* (Caltrans, 2000). The *AASHTO LRFD Bridge Design Specifications* (AASHTO, 2012), however, no longer specify a limit on the cross frame spacing, but instead require rational analysis to investigate needs for all stages of assumed construction procedures and the final conditions. Spacing should be compatible with the transverse stiffeners.

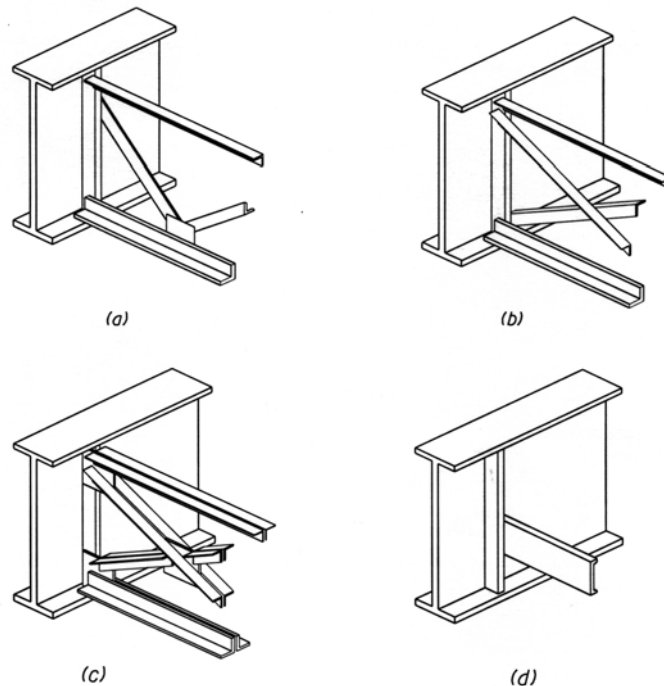

Figure 9.3-1 Typical Diaphragms and Cross Frames

9.3.3.2 Orientation

Intermediate cross frames shall be placed parallel to the skew up to a 20° skew and normal to the girders for a skew angle larger than 20°. On skewed bridges with cross frames placed normal to the girders, there may be situations where the cross frames are staggered or discontinuous across the width of the bridge. At these discontinuous cross frames, lateral flange bending stresses may be introduced into the girder flanges and should be considered. Install stiffeners on the back side of connection plates if staggered cross frames are used. Horizontally curved girders should always have the cross frames placed on radial lines.

A good economical design will minimize the number of diaphragms with varying geometries. Superelevation changes, vertical curves, different connection plate widths, and flaring girders all work against this goal.

9.3.3.3 Connections

Cross frames are typically connected to transverse stiffeners. The stiffeners shall have a positive connection to the girder flange and may either be bolted or welded, although welding is preferred.

For bridges built in stages or with larger skew angles, differential deflections between girders due to slab placement can be significant. If differential deflections are significant, slotted holes and hand tight erection bolts with jamb nuts shall be provided during concrete placement, and permanent bolts fully tensioned or field welded connections shall be installed after the barriers are placed. The bolt holes can be field drilled to insure proper fit. Intermediate cross frames between stages shall be eliminated if possible.

9.3.3.4 Design Guidelines

- The diaphragm or cross frame shall be as deep as practicable to transfer lateral load and to provide lateral stability. They shall be at least 0.5 of the beam depth for rolled beams and 0.75 of the girder depth for plate girders (AASHTO 6.7.4.2).
- Cross frames should be designed and detailed such that they can be erected as a single unit, and all welding during fabrication should be done from one side to minimize handling costs. As a minimum, cross frames shall be designed to resist lateral wind loads. A rational analysis is preferred to determine actual lateral forces.

- End diaphragms and cross frames at bearings shall be designed to resist all lateral forces transmitted to the substructure. Unless they are detailed as ductile elements, the end diaphragms or cross frames shall be designed to resist the overstrength shear capacity of the substructures. Shear connectors should be provided to transfer lateral loads from the deck to the end diaphragm in accordance with the Caltrans *Guide Specifications for Seismic Design of Steel Bridges* (Caltrans 2014). When an expansion joint occurs at a support, the end diaphragm shall be designed to resist truck wheel and impact loads.
- Effective slenderness ratios (KL/r) for compression diagonals shall be less than or equal to 120 and 140 for horizontally curved girders and straight girders, respectively (AASHTO 6.9.3); and for tension members (L/r) less than or equal to 240 (AASHTO 6.8.4).
- Cross frame members and gussets consisting of single angle or WT shapes should be designed for the eccentricity inherent at the gusset connections. Use rectangular gusset plates in lieu of multi-sided polygons.
- Steel plate, I girder, and concrete diaphragms may be used at abutments and piers. The use of integral abutments, piers, and bents is encouraged.

9.3.4 Lateral Bracing

Bottom chord lateral bracing should be avoided because the bracing creates fatigue-sensitive details and is costly to fabricate, install, and maintain. Flange sizes should be sufficient to preclude the need for bottom flange lateral bracing.

9.3.5 Field Splice Locations

Field splices shall preferably be located at points of dead load contraflexure and at points of section change and spaced more than 50 ft. apart. The splice locations are also dependent on shipping and fabrication limits. The length of shipping piece is usually less than 125 ft. and weight less than 40 tons. It is not necessary to locate the splices at the exact contraflexure point, but they should be reasonably close. Field splices are sometimes required to be placed near points of maximum moment in longer spans in order to meet erection requirements. Field splices should always be bolted. Welded field splices shall not be used (CA 6.13.6.2). Adjacent girders should be spliced in approximately the same location.

9.3.6 Expansion Joints and Hinges

In-span hinges are generally not recommended for steel bridges since there are not many acceptable solutions for the design of hinges to resist seismic loads. Steel bridges have been designed without expansion joints and hinges at lengths up to 1200 ft. When dropped cap bents are utilized, the superstructure may be separated from the

substructure with expansion bearings to prevent undue temperature effects on the substructure.

9.4 SECTION PROPORTION

9.4.1 Depth to Span Ratios

Figure 9.4-1 shows a typical portion of a composite I-girder bridge consisting of a concrete deck and built-up plate girder I-section with stiffeners and cross frames. The first step in the structural design of a plate girder bridge is to initially size the web and flanges.

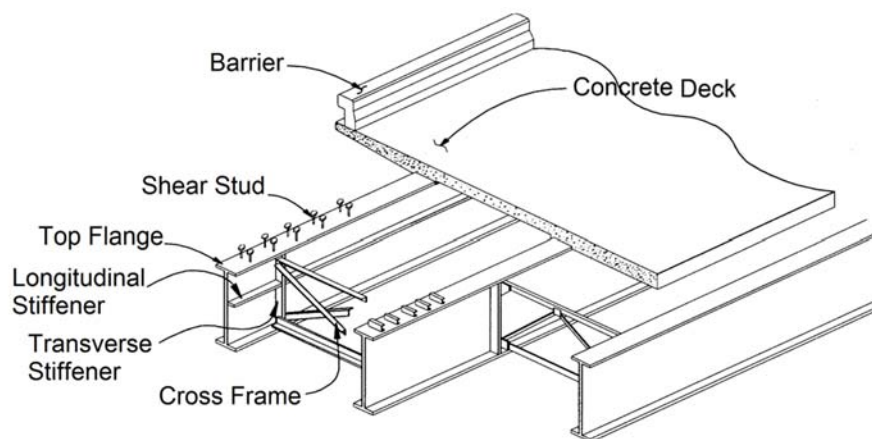

Figure 9.4-1 Components of Typical I-Girder Bridge

For straight girders, AASHTO Table 2.5.2.6.3-1 specifies the minimum ratio of the depth of steel girder portion to the span length is 0.033 for simply supported spans and 0.027 for continuous spans; the minimum ratio of the overall depth (concrete slab plus steel girder) to span length is 0.04 for simply supported spans and 0.032 for continuous spans. Caltrans traditionally prefers that the minimum ratio of overall depth to span length is 0.045 for simply supported spans and 0.04 for continuous spans. For horizontally curved girders, the minimum depth will more than likely need to be increased by 10 to 20%.

9.4.2 Webs

The web mainly provides shear strength for the girder. Since the web contributes little to the bending resistance, its thickness should be as small as practical to meet the web depth to thickness ratio limits $D/t_w \leq 150$ for webs without longitudinal stiffeners, and $D/t_w \leq 300$ for webs with longitudinal stiffeners, respectively (AASHTO 6.10.2.1). It is preferable to have web depths in increments of 2 or 3 in.

for convenience. Web depths greater than 120 in. will require both longitudinal and vertical splices.

The web thickness is preferred to be not less than ½ inch. A thinner plate is subject to excessive distortion from welding. The thickness should be sufficient to preclude the need for longitudinal stiffeners. Web thickness should be constant or with a limited number of changes. A reasonable target would be one or two web sizes for a continuous girder and one web size for a simple span. Web thickness increments should be 1/16 in. or 1/8 in. for plate thicknesses up to 1 inch, and ¼ inch increments for plates greater than 1 inch.

9.4.3 Flanges

The flanges provide bending strength. Flanges should be at least 12 in. wide. A constant flange width for the entire length of the girder is preferred. If the flange area needs to be increased, it is preferable to change the flange thickness. If flange widths need to be changed, it is best to change the width at field splices only. Width increments should be in multiples of 2 or 3 inches. For horizontally curved girders, the flange width should be about one-fourth of the web depth. For straight girders, a flange width of approximately one-fifth to one-sixth of the web depth should be sufficient.

For straight girders, the minimum flange thickness should be ¾ inch. For curved girders, 1 in. thickness is a practical minimum. The desirable maximum flange thickness is 3 inches. Grade 50 and HPS 70W steels are not available in thicknesses greater than 4 inches. Flange thickness increments should be 1/8 in. for thicknesses up to 1 in., 1/4 in. from 1 to 3 in., and 1/2 in. from 3 to 4 inches. At the locations where the flange thickness is changed, the thicker flange should provide about 25 percent more area than the thinner flange. In addition, the thicker flange should be not greater than twice the thickness of the thinner flange.

Both the compression and tension flanges shall meet the following proportion requirements (AASHTO 6.10.2.2) as follows:

$$\frac{b_f}{2t_f} \leq 12 \quad (\text{AASHTO 6.10.2.2-1})$$

$$b_f \geq \frac{D}{6} \quad (\text{AASHTO 6.10.2.2-2})$$

$$t_f \geq 1.1t_w \quad (\text{AASHTO 6.10.2.2-3})$$

$$0.1 \leq \frac{I_{yc}}{I_{yt}} \leq 10 \quad (\text{AASHTO 6.10.2.2-4})$$

where b_f and t_f are full width and thickness of the flange (in.); t_w is web thickness (in.); I_{yc} and I_{yt} are the moment of inertia of the compression flange and the tension flange about the vertical axis in the plane of web, respectively (in.⁴); D is web depth

(in.). Equation AASHTO 6.10.2.2-1 ensures the flange will not distort excessively when welded to the web. Equation AASHTO 6.10.2.2-2 ensures that stiffened interior web panels can develop post-elastic buckling shear resistance by the tension field action. Equation AASHTO 6.10.2.2-3 ensures that flanges can provide some restraint and proper boundary conditions to resist web shear buckling. Equation AASHTO 6.10.2.2-4 ensures more efficient flange proportions and prevents the use of sections that may be difficult to handle during construction. It also ensures that the lateral torsional buckling formulas used in AASHTO are valid.

9.4.4 Stiffeners

Intermediate transverse stiffeners together with the web are used to provide post-elastic shear buckling resistance by the tension field action and are usually placed near the supports and large concentrated loads. Stiffeners without connecting cross frames/diaphragms are typically welded to the girder web and shall be welded to the compression flange and fitted tightly to the tension flange (CA 6.10.11.1.1). Stiffener plates are preferred to have even inch widths from the flat bar stock sizes.

Bearing stiffeners are required at all bearing locations. Bearing stiffeners shall be welded or bolted to both sides of the web. Bearing stiffeners should be thick enough to preclude the need for multiple pairs of bearing stiffeners to avoid multiple-stiffener fabrication difficulties. AASHTO 6.10.11.2 requires that the stiffeners shall extend the full depth of the web and as close as practical to the edge of the flanges.

Longitudinal stiffeners are required to increase flexure resistance of the web by controlling lateral web deflection and preventing the web bending buckling. They are, therefore, attached to the compression portion of the web. It is recommended that sufficient web thickness be used to eliminate the need for longitudinal stiffeners as they can cause difficulty in fabrication and create fatigue-prone details.

9.5 STRUCTURAL MODELING AND ANALYSIS

Steel girder bridges are commonly modeled as beam elements and analyzed as unshored construction. Flexural stiffness of composite section is assumed over the entire bridge length even though the negative moment regions may be designed as non-composite for the section capacity. Longitudinal reinforcing steel in the top mat of the concrete deck within the effective deck width is generally not included in calculating section properties.

In the preliminary analysis, a constant flexural stiffness may be assumed. In the final analysis of composite flexural members, the stiffness properties of the steel section alone for the loads applied to noncomposite sections, the stiffness properties of the long-term composite section for permanent loads applied to composite sections, and the stiffness properties of the short-term composite section properties for transient loads, shall be used over the entire bridge length (AASHTO 6.10.1.5), respectively.

Dead loads are usually distributed to the girders based on tributary area. Live loads distribution is dependent on the girder spacing S , span length L , concrete slab depth t_s , longitudinal stiffness parameter K_g , and number of girders N_b (AASHTO 4.6.2.2.1).

The more refined analysis using the finite element method may be used in analyzing complex bridge systems such as skewed and horizontally curved bridges.

9.6 DESIGN LIMIT STATES AND PROCEDURES

9.6.1 Design Limit States

Steel girder bridges shall be designed to meet the requirements for all applicable limit states specified by AASHTO (2012) and the California Amendments (Caltrans 2014) such as Strength I, Strength II, Service II, Fatigue I and II, and extreme events. Constructability (AASHTO 6.10.3) must be considered. See Chapters 3, 4, and 6 for more detailed discussion.

9.6.2 Design Procedure

The steel girder design may follow the flowchart as shown in Figure 9.6-1.

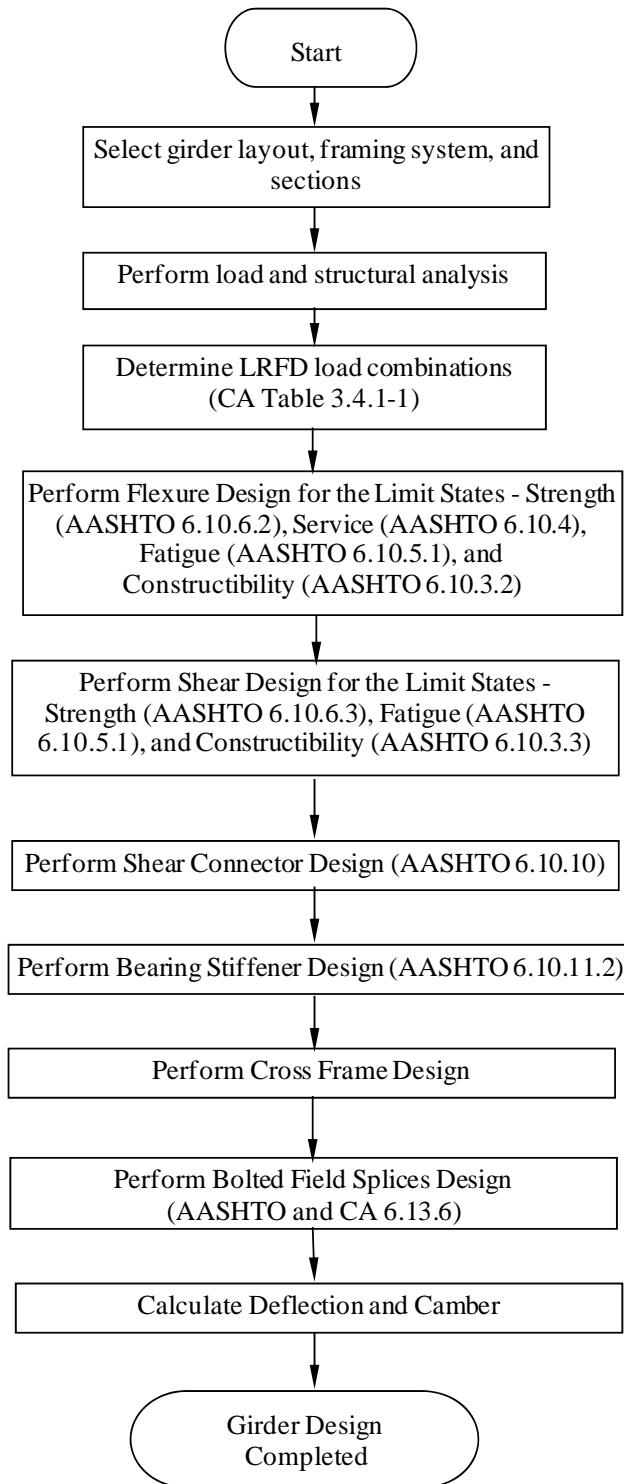

Figure 9.6-1 Steel I-Girder Design Flowchart

9.7 DESIGN EXAMPLE – THREE-SPAN CONTINUOUS COMPOSITE PLATE GIRDER BRIDGE

9.7.1 Steel Girder Bridge Data

A three-span continuous composite plate girder bridge has spans of 110 ft – 165 ft – 125 ft. The superstructure is 58 ft wide. The elevation and plan are shown in Figure 9.7-1.

Structural steel: A 709 Grade 50 for web, flanges and splice plates $F_y = 50$ ksi
 A 709 Grade 36 for cross frames and stiffeners, etc. $F_y = 36$ ksi
 Concrete: $f'_c = 3600$ psi; $E_c = 3,640$ ksi; modular ratio $n = 8$
 Deck: Concrete deck slab thickness = 9.125 in.
 Construction: Unshored construction

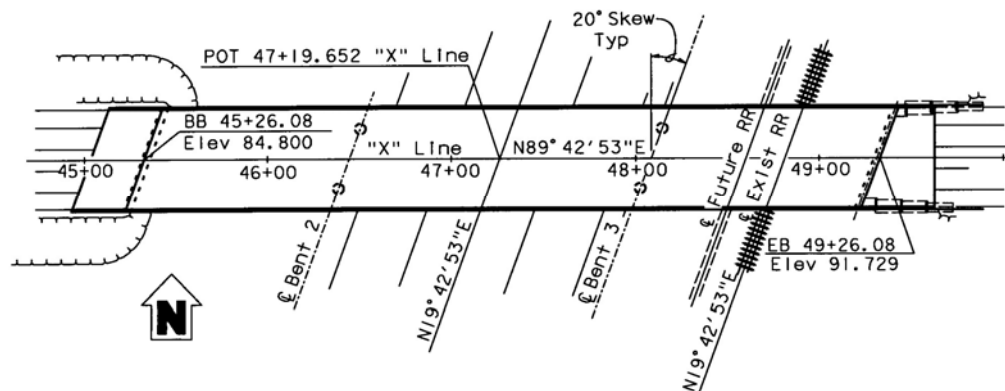
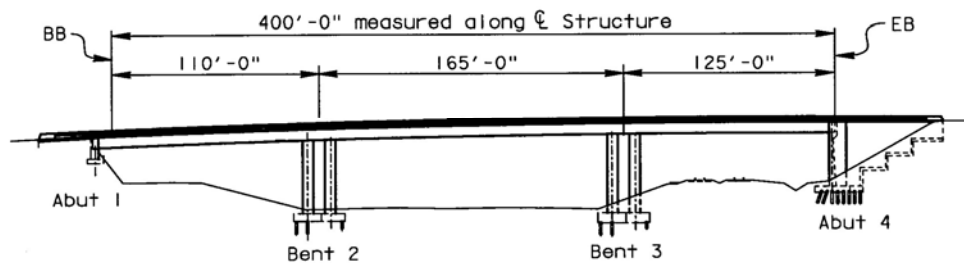

Figure 9.7-1 Three-span Continuous Steel Plate Girder Bridge

9.7.2 Design Requirements

Perform the following design portions for an interior plate girder in accordance with the *AASHTO LRFD Bridge Design Specifications*, 6th Edition (AASHTO 2012) with the *California Amendments* (Caltrans 2014).

- Select Girder Layout and Sections
- Perform Load and Structural Analysis
- Calculate Live Load Distribution Factors
- Determine Load and Resistance Factors and Load Combinations
- Calculate Factored Moments and Shears – Strength Limit States
- Calculate Factored Moments and Shears – Fatigue Limit States
- Calculate Factored Moments – Service Limit State II
- Design Composite Section in Positive Moment Region at 0.5 Point of Span 2
- Design Noncomposite Section in Negative Moment Region at Bent 3
- Design Shear Connectors for Span 2
- Design Bearing Stiffeners at Bent 3
- Design Intermediate Cross Frames
- Design Bolted Field Splices
- Calculate Camber and Plot Camber Diagram
- Identify and Designate Steel Bridge Members and Components

The following notation is used in this example:

- “AASHTO xxx” denotes “AASHTO Article xxx”
- “AASHTO xxx-x” denotes “AASHTO Equation/Table xxx-x”
- “CA xxx” denotes “California Amendment Article xxx”
- “CA xxx-x” denotes “California Amendment Equation/Table xxx-x”
- “MTD xxx” denotes “Caltrans Bridge Memo to Designers Article xxx”

9.7.3 Select Girder Layout and Sections

9.7.3.1 Select Girder Spacing

A girder spacing of 12 ft is selected as shown in Figure 9.7-2a.

9.7.3.2 Select Intermediate Cross Frame Spacing

Cross frames at spacing of 27.5 ft and 25 ft are selected as shown in Figure 9.7-3 to accommodate transverse stiffener spacing for web design and to facilitate a reduction in required flange thickness of the girder section at the bent.

9.7.3.3 Select Steel Girder Section for Positive Flexure Regions

The cross section is usually proportioned based on past practice and proportion limits specified in AASHTO 6.10.2. Interior girder section is shown in Figures 9.7-2b and 9.7-4. Haunch depth shall be carefully selected by considering road slope, top flange thickness, correction of sagging and cambers, embedment of shear connectors as discussed in MTD 12-4 (Caltrans, 2004a).

Top Compression Flange

The maximum transported length of a steel plate girder is generally limited to a length of about 120 ft and a weight of about 180 kips and may vary due to the locations. It is common practice that the unsupported length of each shipping piece divided by the minimum width of compression flange should be less than or equal to about 85 (AASHTO C 6.10.3.4). For a length of 120 ft, the width of compression flange is preferably larger than $(120 \times 12) / 85 = 17$ in. Try top compression flange $b_{fc} \times t_{fc} = 18 \times 1$ (in. \times in.).

Web

AASHTO Table 2.5.2.6.3-1 specifies that for composite girders, the minimum ratio of the depth of steel girder portion to the length of span is 0.033 for simple span and 0.027 for continuous spans. For this design example, the depth of steel girder shall be larger than $0.027(165) = 4.46$ ft. = 53.5 in. Try web $D \times t_w = 78 \times 0.625$ (in. \times in.).

Bottom Tension Flange

Try bottom tension flange $b_{ft} \times t_{ft} = 18 \times 1.75$ (in. \times in.).

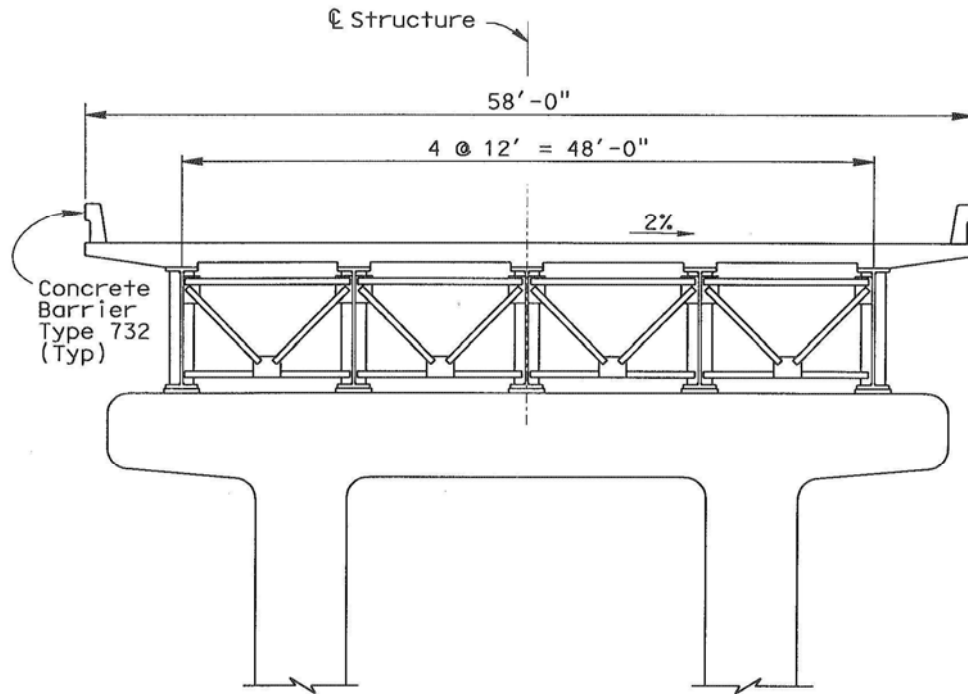

(a) Bridge Cross Section

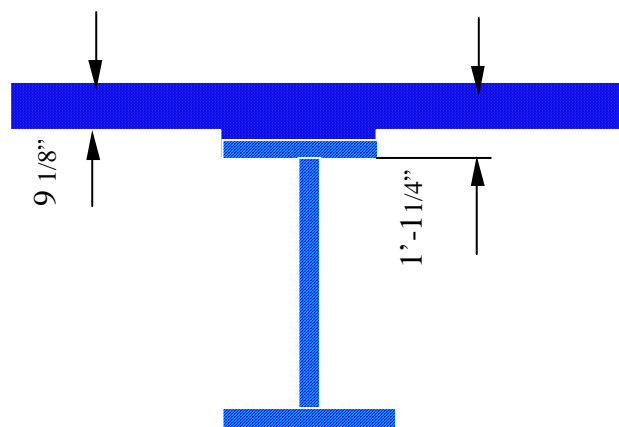

(b) Interior Girder Section

Figure 9.7-2 Typical Cross Sections

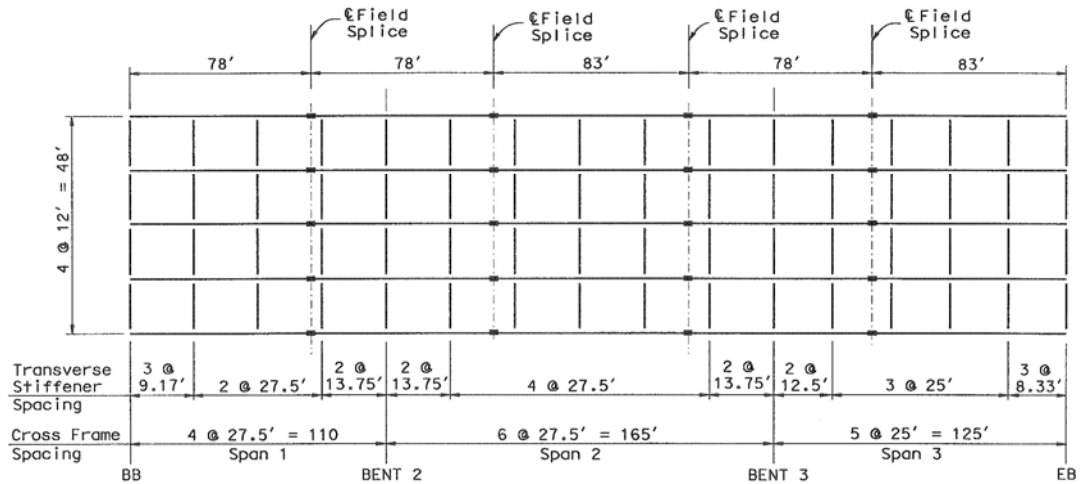
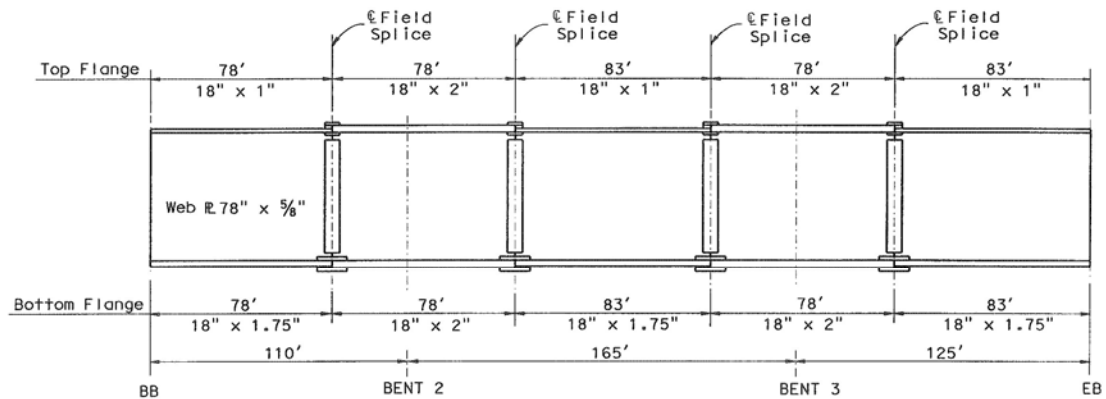

Figure 9.7-3 Framing Plan

(Skew not Shown)



For convenience in this example, the ends of the girder have been assumed to match the BB and EB locations.

Figure 9.7-4 Elevation of Interior Girder

Check Section Proportion Limits

- Web without longitudinal stiffeners

$$\frac{D}{t_w} = \frac{78}{0.625} = 124.8 < 150 \quad \text{O.K.} \quad (\text{AASHTO 6.10.2.1.1-1})$$

- Compression flange

$$\frac{b_{fc}}{2t_{fc}} = \frac{18}{2(1.0)} = 9 < 12 \quad \text{O.K.} \quad (\text{AASHTO 6.10.2.2-1})$$

$$b_{fc} = 18 > \frac{D}{6} = \frac{78}{6} = 13 \quad \text{O.K.} \quad (\text{AASHTO 6.10.2.2-2})$$

$$t_{fc} = 1.0 \text{ in.} > 1.1t_w = 1.1(0.625) = 0.69 \text{ in.} \quad \text{OK.} \\ (\text{AASHTO 6.10.2.2-3})$$

- Tension flange

$$\frac{b_{ft}}{2t_{ft}} = \frac{18}{2(1.75)} = 5.14 < 12 \quad \text{O.K.} \quad (\text{AASHTO 6.10.2.2-1})$$

$$b_{ft} = 18 > \frac{D}{6} = \frac{78}{6} = 13 \quad \text{O.K.} \quad (\text{AASHTO 6.10.2.2-2})$$

$$t_{ft} = 1.75 \text{ in.} > 1.1t_w = 1.1(0.625) = 0.69 \text{ in.} \quad \text{OK.} \\ (\text{AASHTO 6.10.2.2-3})$$

- Flanges Ratio

The flange shall meet the requirement of $0.1 \leq (I_{yc} / I_{yt}) \leq 10$, where I_{yc} and I_{yt} are the moment of inertia of the compression flange and the tension flange about the vertical axis in the plane of web, respectively. This limit ensures more efficient flange proportions and prevents the use of sections that may be difficult to handle during construction. It also ensures that the lateral torsional buckling formulas are valid.

$$0.1 < \frac{I_{yc}}{I_{yt}} = \frac{(1)(18)^3 / 12}{(1.75)(18)^3 / 12} = 0.57 < 10 \quad \text{O.K.} \\ (\text{AASHTO 6.10.2.2-4})$$

9.7.3.4 Select Steel Girder Section for Negative Flexure Regions

Flanges

In the negative moment region, non-composite symmetric steel section is generally used. Try flange plates $b_f \times t_f = 18 \times 2$ (in. \times in.).

Web

It is more cost effective to use one thickness plate for the web through whole bridge. Try web $D \times t_w = 78 \times 0.625$ (in. \times in.).

Check Section Proportion Limits

- Web without longitudinal stiffeners:

$$\frac{D}{t_w} = \frac{78}{0.625} = 124.8 < 150 \quad \text{O.K.} \quad (\text{AASHTO 6.10.2.1.1-1})$$

- Compression and tension flanges

$$\frac{b_f}{2t_f} = \frac{18}{2(2.0)} = 4.5 < 12 \quad \text{O.K.} \quad (\text{AASHTO 6.10.2.2-1})$$

$$b_f = 18 > \frac{D}{6} = \frac{78}{6} = 13 \quad \text{O.K.} \quad (\text{AASHTO 6.10.2.2-2})$$

$$t_f = 2.0 \text{ in.} > 1.1t_w = 1.1(0.625) = 0.69 \text{ in.}$$

O.K. (AASHTO 6.10.2.2-3)

- Flange ratio

$$0.1 < \frac{I_{yc}}{I_{yt}} = \frac{(2)(18)^3 / 12}{(2)(18)^3 / 12} = 1.0 < 10$$

O.K. (AASHTO 6.10.2.2-4)

9.7.3.5 Select Transverse Stiffeners

It is normal to use stiffener width of 7.5 in. to provide allowances for gusset plate connections of cross frames. Try a pair of stiffeners $b_t \times t_p = 7.5 \times 0.5$ (in. \times in.).

9.7.3.6 Select Bolted Splice Locations

For flexural members, splices shall preferably be made at or near points of dead load contraflexure in continuous spans and at points of the section change. As shown in Figure 9.7-3, splices locations for Spans 1 and 3 are selected approximately at 0.7 and 0.3 points, respectively, and for Span 2 are selected approximately at 0.3 and 0.7 points.

9.7.4 Perform Load and Structural Analysis

9.7.4.1 Calculate Permanent Loads for an Interior Girder

The permanent load or dead load of an interior girder includes *DC* and *DW*. *DC* is dead load of structural components and nonstructural attachments. *DW* is dead load of wearing surface. For design purposes, the two parts of *DC* are defined as, *DC1*, structural dead load, acting on the non-composite section, and *DC2*, nonstructural dead load, acting on the long-term composite section.

DC1 usually consists of deck slab concrete (unit weight 150 lbs/ft³), steel girder including bracing system and details (estimated weight 460 lbs/ft for each girder), and an additional 10 percent of deck weight between girders to compensate for the use of permanent steel deck forms as specified in MTD 8-7 (Caltrans, 2015) for bridges designed that are over vehicular or rail traffic in Climate Areas I and II. *DC1* is assumed to be distributed to each girder by the tributary area. The tributary width for the interior girder is 12 feet.

$$DC1 = [(1.1)(9.125/12)(12 - 1.5) + (1.5)(13.25 - 1.5)/12](0.15) + 0.46 = 2.0 \text{ kip/ft}$$

DC2 usually consists of the barrier rails and specified utility. Type 732 Concrete Barriers (0.41 kips/ft and bottom width = 1.43 ft) are used and no utility is considered for this bridge. *DC2* is assumed to be distributed equally to each girder.

$$DC2 = (2)(0.41)/5 = 0.164 \text{ kip/ft}$$

A future wearing surface 35 psf as specified in MTD 15-17 (Caltrans 1988) is assumed. *DW* is assumed to be distributed equally to each girder.

$$\begin{aligned} DW &= (\text{deck width} - \text{barrier width}) (\text{wearing surface pressure})/5 \\ &= [58 - 2(1.43)] (0.035)/5 = 0.386 \text{ kip/ft} \end{aligned}$$

9.7.4.2 Determine Live Load and Dynamic Load Allowance

The design live load *LL* is the AASHTO HL-93 (AASHTO 3.6.1.2) and Caltrans P15 vehicular live loads (CA 3.6.1.8). To consider the wheel-load impact from moving vehicles, the dynamic load allowance *IM* = 33% for the Strength I Limit State, 25% for the Strength II Limit State, and 15% for the Fatigue Limit States are used (CA Table 3.6.2.1-1).

9.7.4.3 Perform Structural Analysis

A structural analysis for three-span continuous beams shall be performed to obtain moments and shear effects due to dead loads and live loads including impact. In the preliminary analysis, a constant flexural stiffness may be assumed. In the final analysis of composite flexural members, the stiffness properties of the steel section alone for the loads applied to noncomposite sections, the stiffness properties of the long-term composite section for permanent loads applied to composite sections and

the stiffness properties of the short-term composite section properties for transient loads, shall be used over the entire bridge length (AASHTO 6.10.1.5), respectively. In this design example, the analysis is performed by the CT-Bridge computer program and checked by the CSiBridge program. A constant flexural stiffness is assumed for simplicity.

Unfactored dead load for an interior girder and live load moments, shears, and support forces for one lane loaded are listed in Tables 9.7-1, 9.7-2, and 9.7-3, respectively. Unfactored moment and shear envelopes for one lane loaded in Span 2 are plotted in Figures 9.7-5 and 9.7-6, respectively.

Table 9.7-1 Unfactored Dead and Live Load Moments

Span	Point <i>x/L</i>	Dead Load			Live Load			
		(Interior Girder)			(One Lane)			
		<i>DC1</i>	<i>DC2</i>	<i>DW</i>	<i>(LL+IM)HL-93</i>		<i>(LL+IM)P15</i>	
		<i>M_dc1</i> (kip-ft)	<i>M_dc2</i> (kip-ft)	<i>M_dw</i> (kip-ft)	<i>+M</i> (kip-ft)	<i>-M</i> (kip-ft)	<i>+M</i> (kip-ft)	<i>-M</i> (kip-ft)
1	0.0	0	0	0	0	0	0	0
	0.1	693	57	135	1143	-249	1937	-576
	0.2	1144	94	223	1960	-498	3236	-1152
	0.3	1353	111	264	2465	-747	4118	-1728
	0.4	1329	108	258	2713	-996	4564	-2304
	0.5	1045	86	204	2702	-1245	4473	-2880
	0.6	528	43	103	2470	-1495	4092	-3457
	0.7	-231	-19	-45	1995	-2104	3136	-4033
	0.8	-1232	-101	-240	1317	-2404	1758	-4609
	0.9	-2474	-203	-483	585	-2796	931	-5185
1.0	-3959	-325	-772	489	-3426	1035	-5782	
2	0.0	-3959	-325	-772	489	-3426	1035	-5782
	0.1	-1555	-128	-303	638	-1802	623	-2877
	0.2	304	25	59	1585	-961	2442	-1857
	0.3	1619	133	316	2586	-838	4883	-1537
	0.4	2389	196	466	3236	-751	6316	-1216
	0.5	2615	215	510	3455	-727	6897	-1218
	0.6	2297	188	448	3274	-886	6410	-1669
	0.7	1434	118	280	2660	-1045	5021	-2119
	0.8	26	2	5	1663	-1220	2661	-2570
	0.9	-1926	-158	-376	643	-1998	687	-3075
1.0	-4422	-363	-862	360	-3563	705	-5981	
3	0.0	-4422	-363	-862	360	-3563	705	-5981
	0.1	-2574	-211	-502	574	-2663	635	-4821
	0.2	-1038	-85	-202	1417	-2237	2058	-4285
	0.3	186	15	36	2245	-1623	3814	-3750
	0.4	1097	90	214	2832	-1391	5068	-3214
	0.5	1695	139	331	3136	-1159	5723	-2678
	0.6	1981	162	386	3168	-927	5737	-2143
	0.7	1955	160	381	2893	-696	5167	-1607
	0.8	1616	133	315	2303	-464	4112	-1071
	0.9	964	79	188	1344	-232	2419	-536
1.0	0	0	0	0	0	0	0	

Table 9.7-2 Unfactored Dead and Live Load Shears

Span	Point <i>x/L</i>	Dead Load			Live Load			
		(Interior Girder)			(One Lane)			
		<i>DC1</i>	<i>DC2</i>	<i>DW</i>	<i>(LL+IM)HL-93</i>		<i>(LL+IM)P15</i>	
		<i>V_DC1</i> (kip)	<i>V_DC2</i> (kip)	<i>V_DW</i> (kip)	+ <i>V</i> (kip)	- <i>V</i> (kip)	+ <i>V</i> (kip)	- <i>V</i> (kip)
1	0.0	74.0	6.1	14.4	116.2	-22.6	210.2	-52.4
	0.1	52.0	4.3	10.1	100.8	-23.1	176.1	-52.4
	0.2	30.0	2.5	5.9	83.8	-25.6	137.8	-52.4
	0.3	8.0	0.7	1.6	67.9	-37.9	105.3	-62.9
	0.4	-14.0	-1.1	-2.7	53.4	-52.0	77.4	-83.7
	0.5	-36.0	-3.0	-7.0	38.2	-66.7	50.0	-109.2
	0.6	-58.0	-4.8	-11.3	28.6	-81.2	35.7	-138.5
	0.7	-80.0	-6.6	-15.6	18.5	-96.0	21.0	-170.9
	0.8	-102.0	-8.4	-19.9	10.7	-110.6	10.8	-200.1
	0.9	-124.0	-10.2	-24.2	5.2	-124.9	9.4	-227.7
1.0	-146.0	-12.0	-28.5	4.5	-136.8	9.4	-262.5	
2	0.0	162.2	13.3	31.6	147.1	-12.9	325.5	-27.3
	0.1	129.2	10.6	25.2	130.7	-13.3	279.2	-27.4
	0.2	96.2	7.9	18.8	112.0	-16.4	225.5	-27.3
	0.3	63.2	5.2	12.3	93.2	-27.7	173.9	-33.5
	0.4	30.2	2.5	5.9	74.8	-41.4	127.8	-57.2
	0.5	-2.8	-0.2	-0.5	55.5	-57.2	86.5	-88.2
	0.6	-35.8	-2.9	-7.0	41.4	-74.4	58.5	-124.0
	0.7	-68.8	-5.6	-13.4	27.4	-92.7	34.2	-169.5
	0.8	-101.8	-8.3	-19.9	15.8	-111.7	19.4	-220.6
	0.9	-134.8	-11.1	-26.3	10.3	-130.5	19.4	-274.3
1.0	-167.8	-13.8	-32.7	9.9	-147.2	19.4	-321.0	
3	0.0	160.4	13.2	31.3	141.9	-2.9	290.1	-5.6
	0.1	135.4	11.1	26.4	129.3	-4.5	249.7	-5.6
	0.2	110.4	9.1	21.5	114.2	-10.0	205.7	-11.1
	0.3	85.4	7.0	16.6	98.9	-18.3	175.3	-21.8
	0.4	60.4	5.0	11.8	83.4	-28.6	142.1	-37.5
	0.5	35.4	2.9	6.9	65.9	-40.7	103.5	-58.1
	0.6	10.4	0.9	2.0	52.9	-54.3	78.9	-83.4
	0.7	-14.6	-1.2	-2.9	38.3	-69.5	56.4	-114.4
	0.8	-39.6	-3.2	-7.7	24.6	-86.1	42.9	-151.3
	0.9	-64.6	-5.3	-12.6	19.0	-104.1	42.9	-193.5
1.0	-89.6	-7.3	-17.5	18.6	-120.8	42.9	-233.7	

Table 9.7-3 Unfactored Support Forces

Location	Dead Load			Live Load	
	(Interior Girder)			(One Lane)	
	<i>DC1</i>	<i>DC2</i>	<i>DW</i>	<i>(LL+IM)HL-93</i>	
	<i>R_DC1</i> (kip)	<i>R_DC2</i> (kip)	<i>R_DW</i> (kip)	+ <i>R</i> (kip)	+ <i>R</i> (kip)
Abutment 1	74.0	6.1	14.4	116.2	210.2
Bent 2	308.2	25.3	60.1	244.5	445.3
Bent 3	328.2	27.0	64.0	249.2	447.0
Abutment 4	89.6	7.3	17.5	120.8	233.7

9.7.5 Calculate Live Load Distribution Factors

9.7.5.1 Check Ranges of Applicability of Live Load Distribution Factors

For beam-slab bridges, the distribution of live load is dependent on the girder spacing S , span length L , concrete slab depth t_s , longitudinal stiffness parameter K_g , and number of girders N_b . This example is categorized Type “a” (AASHTO Table 4.6.2.2.1-1).

The preliminary section shown in Table 9.7-4 is assumed to estimate the longitudinal stiffness parameter, K_g (AASHTO 4.6.2.2.1-1) for the positive moment region in Span 2.

Table 9.7-4 Preliminary Section Properties

Component	A_i (in. ²)	y_i (in.)	$A_i y_i$ (in. ³)	$y_i - y_{NCb}$ (in.)	$A_i (y_i - y_{NCb})^2$ (in. ⁴)	I_o (in. ⁴)
Top flange 18 × 1	18.00	80.25	1,444.5	45.05	36,531	1.5
Web 78 × 0.625	48.75	40.75	1,986.6	5.55	1,502	24,716
Bottom flange 18 × 1.75	31.50	0.875	27.6	-34.325	37,113	8.04
Σ	98.25	-	3,458.7	-	75,146	24,726

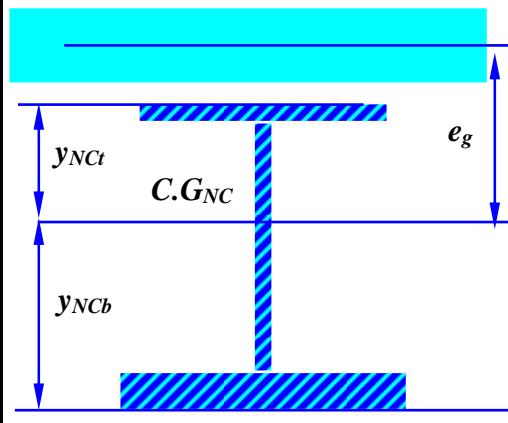

$y_{NCb} = \frac{\sum A_i y_i}{\sum A_i} = \frac{3,458.7}{98.25} = 35.2 \text{ in.}$

$y_{NCt} = (1.75 + 78 + 1) - 35.2 = 45.55 \text{ in.}$

$I_{NC} = \sum I_o + \sum A_i (y_i - y_{NCb})^2$
 $= 24,726 + 75,146 = 99,872 \text{ in.}^4$

$e_g = 45.55 - 1.0 + 13.25 - \frac{9.125}{2} = 53.24 \text{ in.}$

$K_g = n(I_{NC} + A e_g^2) = 8 \left[99,872 + (98.25)(53.24)^2 \right] = 3,026,891 \text{ in.}^4$

$y_{NCb} = \frac{\sum A_i y_i}{\sum A_i} = \frac{3,458.7}{98.25} = 35.2 \text{ in.}$

$y_{NCt} = (1.75 + 78 + 1) - 35.2 = 45.55 \text{ in.}$

$I_{NC} = \sum I_o + \sum A_i (y_i - y_{NCb})^2$
 $= 24,726 + 75,146 = 99,872 \text{ in.}^4$

$e_g = 45.55 - 1.0 + 13.25 - \frac{9.125}{2} = 53.24 \text{ in.}$

$K_g = n(I_{NC} + A e_g^2) = 8 \left[99,872 + (98.25)(53.24)^2 \right] = 3,026,891 \text{ in.}^4$

Check ranges of applicability of AASHTO Tables 4.6.2.2.2b-1 and 4.6.2.2.3a-1 for Type “a” structure.

Girder spacing: $3.5 \text{ ft} < S = 12 \text{ ft} < 16 \text{ ft}$
 Span length: $20 \text{ ft} < L = (110, 165 \text{ and } 125) \text{ ft} < 240 \text{ ft}$
 Concrete deck: $4.5 \text{ in.} < t_s = 9.125 \text{ in.} < 12.0 \text{ in.}$
 Number of girders: $N_b = 5 > 4$
 Stiffness parameter: $10,000 \text{ in.}^4 < K_g = 3,026,891 \text{ in.}^4 < 7,000,000 \text{ in.}^4$

It is seen that the girder satisfies the limitation of ranges of applicability of the approximate live load distribution factors specified in AASHTO Tables 4.6.2.2.2b-1 and 4.6.2.2.3a-1. Section type “a” (AASHTO Table 4.6.2.2.1-1) will be used.

For preliminary design, the term $K_g / (12Lt_s^3)$ may be taken as 1.0. Although the K_g term varies slightly along the span and between spans, the distribution factor is typically not sensitive to the value of K_g . For simplicity, the K_g of Span 2 is used for all spans of this example.

9.7.5.2 Determine Span Length for Use in Live Load Distribution Equations

AASHTO Table C4.6.2.2.1-1 recommends the L for use in live load distribution equations as shown in Table 9.7-5.

Table 9.7- 5 Span Length for Use in Live Load Distribution Equations

Force Effects	L (ft)
<ul style="list-style-type: none"> • Positive Moment • Negative Moment—Other than near interior supports of continuous spans • Shear • Exterior Reaction 	The length of the span for which moment/shear/reaction is being calculated
<ul style="list-style-type: none"> • Negative Moment—Near interior supports of continuous spans from point of contraflexure to point of contraflexure under a uniform load on all spans • Interior Reaction of Continuous Span 	The average length of the two adjacent spans

9.7.5.3 Calculate Live Load Distribution Factors

Live load distribution factors are calculated and listed in Tables 9.7-6 and 9.7-7 in accordance with AASHTO Tables 4.6.2.2.2b-1 and 4.6.2.2.3a-1.

One design lane loaded

$$DF_m = 0.06 + \left(\frac{S}{14}\right)^{0.4} \left(\frac{S}{L}\right)^{0.3} \left(\frac{K_g}{12Lt_s^3}\right)^{0.1}; \quad DF_v = 0.36 + \frac{S}{25}$$

Two or more design lanes loaded

$$DF_m = 0.075 + \left(\frac{S}{9.5}\right)^{0.6} \left(\frac{S}{L}\right)^{0.2} \left(\frac{K_g}{12Lt_s^3}\right)^{0.1}; \quad DF_v = 0.2 + \frac{S}{12} - \left(\frac{S}{35}\right)^2$$

$$K_g = 3,026,891 \text{ in.}^4$$

$$S = 12 \text{ ft}$$

$$t_s = 9.125 \text{ in.}$$

**Table 9.7-6 Live Load Distribution Factors for Interior Girder
for Strength Limit State**

Span	Lane loaded	Moment DF_m (Lane)		Shear DF_v (Lane)	
		One	Two or More	One	Two or More
1*	$L = 110$ ft	0.600	0.900	0.840	1.082
1 & 2**	$L = 137.5$ ft	0.554	0.846	0.840	1.082
2*	$L = 165$ ft	0.519	0.805	0.840	1.082
2 & 3**	$L = 145$ ft	0.544	0.834	0.840	1.082
3*	$L = 125$ ft	0.573	0.869	0.840	1.082

Note:

- * The span length for which moment is being calculated for positive moment, negative moment—other than near interior supports of continuous spans, shear, and exterior reaction.
- ** Average span length for negative moment—near interior supports of continuous spans from point of contraflexure to point of contraflexure under a uniform load on all spans, and interior reaction of continuous span.

Multiple lane presence factors have been included in the above live load distribution factors.

It is seen that live load distribution factors for the case of two or more lanes loaded control the strength and service limit states. For the fatigue limit states, since live load is one HL-93 truck or one P9 truck as specified CA 3.6.1.4.1, multiple lane presence factor of 1.2 should be removed from above factors for the case of one lane loaded (AASHTO 3.6.1.1.2).

**Table 9.7-7 Live Load Distribution Factors for Interior Girder
for Fatigue Limit State**

Span	Lane loaded	Moment DF_m (Lane)	Shear DF_v (Lane)
		One	One
1*	$L = 110$ ft	0.500	0.700
1 & 2**	$L = 137.5$ ft	0.462	0.700
2*	$L = 165$ ft	0.433	0.700
2 & 3**	$L = 145$ ft	0.453	0.700
3*	$L = 125$ ft	0.478	0.700

Note:

- * The span length for which moment is being calculated for positive moment, negative moment—other than near interior supports of continuous spans, shear, and exterior reaction.
- ** Average span length for negative moment—near interior supports of continuous spans from point of contraflexure to point of contraflexure under a uniform load on all spans, and interior reaction of continuous span.

9.7.6 Determine Load and Resistance Factors and Load Combinations

A steel girder bridge is usually designed for the Strength Limit State, and checked for the Fatigue Limit State, Service Limit State II, and Constructibility.

9.7.6.1 Determine Design Equation

AASHTO 1.3.2.1 requires that following design equation shall be satisfied for all limit states:

$$\sum \eta_i \gamma_i Q_i \leq \phi R_n = R_r \quad (\text{AASHTO 1.3.2.1-1})$$

where γ_i is load factor and ϕ is resistance factor; Q_i represents force effect; R_n is nominal resistance; η_i is load modifier factor related to ductility, redundancy, and operational importance and is defined as follows when a maximum value of γ_i is used:

$$\eta_i = \eta_D \eta_R \eta_I \geq 0.95 \quad (\text{AASHTO 1.3.2.1-2})$$

where η_D , η_R , and η_I are ductility and redundancy and operational factors, respectively. CA 1.3.3, 1.3.4 and 1.3.5 specify that they are all taken to 1.0 for all limit states. Therefore, $\eta_i = 1.0$. For this example, the design equation becomes:

$$\sum \gamma_i Q_i \leq \phi R_n = R_r$$

9.7.6.2 Determine Applicable Load Factors and Load Combinations

According to CA Table 3.4.1-1, considering live load distribution factors for the interior girder and denoting $(LL+IM)$ as unfactored force effect due to one design lane loaded, the following load combinations are obtained as:

Strength I: $1.25(DC) + 1.5(DW) + 1.75(DF)(LL+IM)_{HL-93}$

Strength II: $1.25(DC) + 1.5(DW) + 1.35(DF)(LL+IM)_{P15}$

Service II: $1.0(DC) + 1.0(DW) + 1.30(DF)(LL+IM)_{HL-93}$

Fatigue I: $1.75(DF)(LL+IM)_{HL-93}$

Fatigue II: $1.0(DF)(LL+IM)_{P9}$

where DF is the live load distribution factor.

9.7.6.3 Determine Applicable Resistance Factors

According to AASHTO 6.5.4.2, the following resistance factors are used for the strength limit states in this example.

For flexure $\phi_f = 1.00$

For shear $\phi_v = 1.00$

For axial compression $\phi_c = 0.90$

For tension, fracture in net section $\phi_u = 0.80$

For tension, yielding in gross section $\phi_y = 0.95$

For bearing on milled surfaces $\phi_b = 1.00$

For bolts bearing on material $\phi_{bb} = 0.80$

For shear connector $\phi_{sc} = 0.85$

For block shear $\phi_{bs} = 0.8$
 For A325 bolts in shear $\phi_s = 0.8$
 For weld metal in fillet weld
 – shear in throat of weld metal $\phi_{e2} = 0.8$

9.7.7 Calculate Factored Moments and Shears – Strength Limit States

Using live load distribution factors in Table 9.7-6, factored moments, shears, and support forces for strength limit states I and II are calculated and listed in Tables 9.7-8, 9.7-9 and 9.7-10, respectively.

Strength I: $1.25(DC) + 1.5(DW) + 1.75(DF)(LL+IM)_{HL-93}$
 Strength II: $1.25(DC) + 1.5(DW) + 1.35(DF)(LL+IM)_{P15}$

Table 9.7-8 Factored Moment Envelopes for Interior Girder

Span	Point <i>x/L</i>	Dead Load			Live Load				Load Combination			
		<i>DC1</i>	<i>DC2</i>	<i>DW</i>	<i>(LL+IM)HL-93</i>		<i>(LL+IM)P15</i>		Strength I		Strength II	
		<i>M_DC1</i> (kip-ft)	<i>M_DC2</i> (kip-ft)	<i>M_DW</i> (kip-ft)	+ <i>M</i> (kip-ft)	- <i>M</i> (kip-ft)	+ <i>M</i> (kip-ft)	- <i>M</i> (kip-ft)	+ <i>M</i> (kip-ft)	- <i>M</i> (kip-ft)	+ <i>M</i> (kip-ft)	- <i>M</i> (kip-ft)
1	0.0	0	0	0	0	0	0	0	0	0	0	0
	0.1	866	71	203	1800	-392	2354	-700	2940	748	3494	440
	0.2	1430	118	335	3087	-784	3932	-1400	4969	1098	5814	482
	0.3	1691	139	396	3882	-1177	5004	-2100	6108	1049	7230	126
	0.4	1661	135	387	4273	-1569	5545	-2800	6456	615	7728	-617
	0.5	1306	108	306	4256	-1961	5434	-3500	5975	-241	7154	-1780
	0.6	660	54	155	3890	-2355	4972	-4200	4759	-1486	5840	-3331
	0.7	-289	-24	-68	3142	-3115	3811	-4606	2762	-3495	3431	-4986
	0.8	-1540	-126	-360	2074	-3559	2136	-5264	48	-5585	110	-7290
	0.9	-3093	-254	-725	921	-4139	1131	-5922	-3149	-8210	-2939	-9992
1.0	-4949	-406	-1158	770	-5072	1257	-6604	-5743	-11585	-5256	-13117	
2	0.0	-4949	-406	-1158	689	-5072	1124	-6604	-5824	-11585	-5389	-13117
	0.1	-1944	-160	-455	899	-2668	677	-3286	-1659	-5226	-1882	-5844
	0.2	380	31	89	2233	-1354	2654	-2018	2733	-854	3154	-1518
	0.3	2024	166	474	3643	-1181	5307	-1670	6307	1483	7971	994
	0.4	2986	245	699	4559	-1058	6864	-1322	8489	2872	10794	2608
	0.5	3269	269	765	4867	-1024	7495	-1324	9170	3278	11797	2979
	0.6	2871	235	672	4612	-1248	6966	-1814	8390	2530	10744	1965
	0.7	1793	148	420	3747	-1472	5456	-2303	6107	888	7816	57
	0.8	33	3	8	2343	-1719	2891	-2793	2385	-1676	2934	-2751
	0.9	-2408	-198	-564	906	-2916	747	-3462	-2263	-6085	-2422	-6631
1.0	-5528	-454	-1293	507	-5200	767	-6734	-6767	-12474	-6508	-14008	
3	0.0	-5528	-454	-1293	547	-5200	828	-6734	-6727	-12474	-6447	-14008
	0.1	-3218	-264	-753	873	-3887	745	-5428	-3361	-8121	-3489	-9662
	0.2	-1298	-106	-303	2155	-3265	2414	-4825	448	-4972	708	-6532
	0.3	233	19	54	3414	-2468	4475	-4399	3719	-2163	4780	-4094
	0.4	1371	113	321	4307	-2115	5946	-3771	6112	-311	7751	-1966
	0.5	2119	174	497	4769	-1763	6714	-3142	7558	1026	9503	-353
	0.6	2476	203	579	4818	-1410	6730	-2514	8075	1848	9988	744
	0.7	2444	200	572	4400	-1058	6061	-1885	7615	2157	9276	1330
	0.8	2020	166	473	3502	-706	4824	-1257	6161	1953	7482	1402
	0.9	1205	99	282	2044	-353	2838	-628	3630	1233	4424	957
1.0	0	0	0	0	0	0	0	0	0	0	0	

Table 9.7-9 Factored Shear Envelopes for Interior Girder

Span	Point x/L	Dead Load			Live Load				Load Combination			
		DC1	DC2	DW	(LL+IM)HL-93		(LL+IM)P15		Strength I		Strength II	
		V_DC1 (kip)	V_DC2 (kip)	V_DW (kip)	+V (kip)	-V (kip)	+V (kip)	-V (kip)	+V (kip)	-V (kip)	+V (kip)	-V (kip)
1	0.0	92.5	7.6	21.6	220.0	-42.8	307.0	-76.5	341.7	78.9	428.7	45.2
	0.1	65.0	5.4	15.2	190.9	-43.7	257.2	-76.5	276.4	41.8	342.8	9.0
	0.2	37.5	3.1	8.9	158.7	-48.5	201.3	-76.5	208.2	1.0	250.8	-27.0
	0.3	10.0	0.9	2.4	128.6	-71.8	153.8	-91.9	141.8	-58.5	167.1	-78.6
	0.4	-17.5	-1.4	-4.1	101.1	-98.5	113.1	-122.2	78.2	-121.4	90.2	-145.1
	0.5	-45.0	-3.8	-10.5	72.3	-126.3	73.1	-159.5	13.1	-185.5	13.8	-218.8
	0.6	-72.5	-6.0	-17.0	54.2	-153.8	52.1	-202.3	-41.3	-249.2	-43.3	-297.8
	0.7	-100.0	-8.3	-23.4	35.0	-181.8	30.7	-249.7	-96.6	-313.4	-101.0	-381.3
	0.8	-127.5	-10.5	-29.9	20.3	-209.4	15.7	-292.3	-147.6	-377.3	-152.1	-460.2
	0.9	-155.0	-12.8	-36.3	9.8	-236.5	13.7	-332.6	-194.2	-440.5	-190.3	-536.6
1.0	-182.5	-15.0	-42.8	8.5	-259.0	13.7	-383.5	-231.7	-499.3	-226.5	-623.7	
2	0.0	202.8	16.6	47.4	278.5	-24.4	475.5	-39.9	545.3	242.3	742.3	226.9
	0.1	161.5	13.3	37.8	247.5	-25.2	407.8	-40.0	460.0	187.4	620.4	172.6
	0.2	120.3	9.9	28.2	212.1	-31.1	329.3	-39.9	370.4	127.3	487.6	118.4
	0.3	79.0	6.5	18.5	176.5	-52.4	254.0	-48.9	280.4	51.5	357.9	55.1
	0.4	37.8	3.1	8.9	141.6	-78.4	186.7	-83.5	191.4	-28.7	236.4	-33.8
	0.5	-3.5	-0.3	-0.8	105.1	-108.3	126.4	-128.9	100.6	-112.8	121.9	-133.4
	0.6	-44.8	-3.6	-10.5	78.4	-140.9	85.5	-181.2	19.5	-199.8	26.6	-240.1
	0.7	-86.0	-7.0	-20.1	51.9	-175.5	49.9	-247.5	-61.2	-288.6	-63.2	-360.6
	0.8	-127.3	-10.4	-29.9	29.9	-211.5	28.4	-322.2	-137.6	-379.0	-139.1	-489.7
	0.9	-168.5	-13.9	-39.5	19.5	-247.1	28.4	-400.7	-202.3	-468.9	-193.5	-622.5
1.0	-209.8	-17.3	-49.1	18.7	-278.7	28.4	-468.9	-257.3	-554.8	-247.7	-745.0	
3	0.0	200.5	16.5	47.0	268.7	-5.5	423.8	-8.2	532.6	258.5	687.7	255.7
	0.1	169.3	13.9	39.6	244.8	-8.5	364.7	-8.2	467.6	214.2	587.4	214.5
	0.2	138.0	11.4	32.3	216.2	-18.9	300.4	-16.3	397.9	162.7	482.1	165.4
	0.3	106.8	8.8	24.9	187.3	-34.7	256.0	-31.8	327.7	105.7	396.4	108.6
	0.4	75.5	6.3	17.7	157.9	-54.2	207.5	-54.8	257.4	45.3	306.9	44.6
	0.5	44.3	3.6	10.4	124.8	-77.1	151.1	-84.9	183.0	-18.8	209.3	-26.7
	0.6	13.0	1.1	3.0	100.2	-102.8	115.3	-121.8	117.3	-85.7	132.4	-104.7
	0.7	-18.3	-1.5	-4.4	72.5	-131.6	82.4	-167.1	48.4	-155.7	58.3	-191.2
	0.8	-49.5	-4.0	-11.6	46.6	-163.0	62.6	-221.1	-18.5	-228.1	-2.5	-286.1
	0.9	-80.8	-6.6	-18.9	36.0	-197.1	62.6	-282.7	-70.3	-303.4	-43.7	-389.0
1.0	-112.0	-9.1	-26.3	35.2	-228.7	62.6	-341.3	-112.2	-376.1	-84.8	-488.7	

Table 9.7-10 Factored Support Forces for Interior Girder

Factored Support Forces							
Location	Dead Load			Live Load		Load Combination	
	(Interior Girder)			(LL+I)HL-93	(LL+I)P15	Strength I	Strength II
	R_DC1 (kip)	R_DC2 (kip)	R_DW (kip)	+R (kip)	+R (kip)	+R (kip)	+R (kip)
Abutment 1	92.5	7.6	21.6	220.0	307.0	341.7	428.8
Bent 2	385.3	31.6	90.2	463.0	650.4	970.0	1157.4
Bent 3	410.3	33.8	96.0	471.9	652.9	1011.9	1192.9
Abutment 4	112.0	9.1	26.3	228.7	341.4	376.1	488.7

9.7.8 Calculate Factored Moments and Shears – Fatigue Limit States

For load-induced fatigue consideration (CA Table 3.4.1-1), the fatigue moment and shear force ranges are caused by live load only and are calculated by the following equations:

$$\text{Fatigue I (HL-93 Truck): } \gamma(\Delta F) = 1.75 (DF)(LL+IM)_{HL-93}$$

$$\text{Fatigue II (P-9 Truck): } \gamma(\Delta F) = 1.0(DF)(LL+IM)_{P9}$$

Using live load distribution factors in Table 9.7-7, fatigue limit moment and shear ranges for an interior girder are calculated and listed in Tables 9.7-11 and 9.7-12. V_u , shear due to the unfactored dead load plus the factored fatigue load (Fatigue I) is also calculated for checking the special fatigue requirement for webs as required by AASHTO 6.10.5.3.

$$V_u = V_{dc1} + V_{dc2} + V_{dw} + (1.75)(DF_v)(LL+IM)_{HL-93}$$

Table 9.7-11 Fatigue I Limit State - Moment and Shears for Interior Girder

Span	Point x/L	Fatigue Moment					Fatigue Shear						
		<i>(LL+IM)HL-93</i>		Factored <i>(LL+IM)HL-93</i>			<i>(LL+IM)HL-93</i>		Factored <i>(LL+IM)HL-93</i>				
		One Lane		Interior Girder			One Lane		Interior Girder				
		+M (kip-ft)	-M (kip-ft)	+M (kip-ft)	-M (kip-ft)	<i>M_{sr}</i> (kip-ft)	+V (kip)	-V (kip)	+V (kip)	-V (kip)	<i>V_{sr}</i> (kip)	+ <i>V_u</i> (kip)	- <i>V_u</i> (kip)
1	0.0	0	0	0	0	0	64.6	-11.1	79.2	-13.6	92.8	173.7	80.9
	0.1	624	-122	546	-107	653	56.7	-11.1	69.4	-13.6	83.1	135.8	52.8
	0.2	1081	-245	946	-214	1160	47.3	-11.1	57.9	-13.6	71.5	96.3	24.8
	0.3	1306	-367	1143	-321	1464	38.3	-15.2	46.9	-18.6	65.4	57.2	-8.3
	0.4	1397	-489	1222	-428	1650	29.8	-23.1	36.4	-28.3	64.7	18.6	-46.1
	0.5	1358	-611	1189	-535	1724	20.5	-32.6	25.1	-40.0	65.1	-20.9	-86.0
	0.6	1264	-734	1106	-642	1748	14.7	-41.8	18.0	-51.2	69.1	-56.1	-125.3
	0.7	1016	-856	889	-692	1581	9.2	-50.5	11.3	-61.8	73.1	-90.9	-164.0
	0.8	640	-978	560	-791	1351	5.5	-58.5	6.7	-71.7	78.4	-123.6	-202.0
	0.9	246	-1101	216	-890	1105	2.3	-66.0	2.9	-80.8	83.7	-155.5	-239.2
1.0	257	-1223	224	-989	1213	2.3	-71.5	2.9	-87.5	90.4	-183.6	-274.0	
2	0.0	257	-1223	194	-989	1183	74.8	-6.8	91.6	-8.3	99.9	298.7	198.8
	0.1	303	-596	229	-482	712	68.3	-6.8	83.7	-8.3	92.0	248.7	156.7
	0.2	843	-509	639	-385	1024	59.9	-6.8	73.3	-8.3	81.6	196.2	114.6
	0.3	1338	-421	1014	-319	1333	50.6	-12.8	62.0	-15.7	77.7	142.7	65.0
	0.4	1638	-333	1241	-252	1494	40.9	-21.1	50.1	-25.8	75.9	88.7	12.8
	0.5	1715	-302	1299	-229	1528	30.0	-30.2	36.8	-37.0	73.8	33.3	-40.5
	0.6	1656	-413	1255	-313	1568	21.9	-39.9	26.8	-48.9	75.7	-18.9	-94.6
	0.7	1375	-525	1042	-398	1440	13.4	-49.6	16.5	-60.8	77.2	-71.3	-148.6
	0.8	891	-637	675	-482	1157	6.9	-59.0	8.4	-72.3	80.7	-121.6	-202.3
	0.9	323	-748	245	-593	838	5.3	-67.7	6.5	-82.9	89.4	-165.7	-255.1
1.0	193	-1139	147	-903	1049	5.3	-74.4	6.5	-91.1	97.6	-207.8	-305.4	
3	0.0	193	-1139	162	-903	1065	73.4	-1.6	89.9	-1.9	91.8	294.8	203.0
	0.1	267	-1025	223	-813	1036	68.0	-2.2	83.3	-2.7	86.0	256.2	170.2
	0.2	719	-911	601	-722	1324	60.7	-5.4	74.4	-6.6	81.0	215.4	134.4
	0.3	1156	-797	967	-667	1634	52.8	-9.2	64.6	-11.3	75.9	173.6	97.7
	0.4	1456	-683	1218	-572	1790	44.1	-15.4	54.1	-18.9	72.9	131.3	58.3
	0.5	1586	-569	1327	-476	1803	33.5	-22.7	41.1	-27.8	68.9	86.3	17.4
	0.6	1628	-456	1362	-381	1743	25.4	-30.7	31.1	-37.7	68.8	44.4	-24.4
	0.7	1525	-342	1276	-286	1561	16.1	-39.4	19.8	-48.3	68.0	1.1	-67.0
	0.8	1215	-228	1017	-191	1207	10.0	-48.6	12.3	-59.5	71.8	-38.2	-110.0
	0.9	728	-114	609	-95	704	9.1	-58.2	11.2	-71.3	82.5	-71.3	-153.8
1.0	0	0	0	0	0	9.1	-66.6	11.2	-81.5	92.7	-103.2	-195.9	

Table 9.7-12 Fatigue II Limit State - Moment and Shears for Interior Girder

Span	Point x/L	Fatigue Moment					Fatigue Shear				
		<i>(LL+IM)P9</i> (One Lane)		Factored <i>(LL+IM)P9</i> (Interior Girder)			<i>(LL+IM)P9</i> (One Lane)		Factored <i>(LL+IM)P9</i> (Interior Girder)		
		+ <i>M</i> (kip-ft)	- <i>M</i> (kip-ft)	+ <i>M</i> (kip-ft)	- <i>M</i> (kip-ft)	<i>M_{sr}</i> (kip-ft)	+ <i>V</i> (kip)	- <i>V</i> (kip)	+ <i>V</i> (kip)	- <i>V</i> (kip)	<i>V_{sr}</i> (kip)
1	0.0	0	0	0	0	0	178.6	-35.4	125.0	-24.8	149.8
	0.1	1686	-390	843	-195	1038	153.2	-35.4	107.3	-24.8	132.1
	0.2	2749	-779	1375	-390	1764	123.7	-35.4	86.6	-24.8	111.4
	0.3	3579	-1169	1789	-584	2374	96.0	-35.4	67.2	-24.8	92.0
	0.4	3904	-1558	1952	-779	2731	71.2	-52.6	49.9	-36.8	86.7
	0.5	3885	-1948	1942	-974	2916	46.0	-74.7	32.2	-52.3	84.5
	0.6	3476	-2337	1738	-1169	2907	32.8	-102.9	23.0	-72.0	95.0
	0.7	2725	-2727	1363	-1260	2622	19.3	-131.6	13.5	-92.1	105.6
	0.8	1542	-3116	771	-1440	2211	9.9	-160.8	6.9	-112.5	119.5
	0.9	714	-3506	357	-1620	1977	7.2	-188.1	5.0	-131.7	136.7
1.0	793	-3895	397	-1800	2196	7.2	-208.9	5.0	-146.2	151.3	
2	0.0	793	-3895	344	-1800	2143	229.2	-20.9	160.4	-14.7	175.1
	0.1	531	-1796	230	-830	1060	205.0	-20.9	143.5	-14.7	158.2
	0.2	2188	-1532	948	-663	1611	174.9	-20.9	122.4	-14.7	137.1
	0.3	3793	-1267	1642	-549	2191	143.1	-28.7	100.2	-20.1	120.3
	0.4	4795	-1003	2076	-434	2511	111.1	-50.4	77.8	-35.3	113.1
	0.5	5144	-933	2228	-404	2632	76.7	-77.5	53.7	-54.3	108.0
	0.6	4857	-1279	2103	-554	2657	52.5	-108.0	36.7	-75.6	112.3
	0.7	3909	-1624	1693	-703	2396	30.1	-139.9	21.1	-97.9	119.0
	0.8	2339	-1970	1013	-853	1866	16.0	-171.8	11.2	-120.3	131.5
	0.9	599	-2315	259	-1049	1308	16.0	-202.4	11.2	-141.7	152.9
1.0	582	-3626	252	-1643	1895	16.0	-227.2	11.2	-159.0	170.2	
3	0.0	582	-3626	278	-1643	1921	220.3	-4.7	154.2	-3.3	157.5
	0.1	524	-3264	250	-1478	1729	199.7	-4.7	139.8	-3.3	143.1
	0.2	1792	-2901	857	-1314	2171	173.0	-10.2	121.1	-7.2	128.3
	0.3	3189	-2538	1524	-1213	2738	144.2	-20.0	100.9	-14.0	115.0
	0.4	4119	-2176	1969	-1040	3009	113.6	-34.5	79.5	-24.2	103.7
	0.5	4639	-1813	2217	-867	3084	80.0	-53.5	56.0	-37.4	93.4
	0.6	4689	-1450	2242	-693	2935	57.7	-76.3	40.4	-53.4	93.8
	0.7	4305	-1088	2058	-520	2578	35.4	-102.8	24.8	-71.9	96.8
	0.8	3330	-725	1592	-347	1938	29.0	-131.4	20.3	-92.0	112.3
	0.9	2023	-363	967	-173	1140	29.0	-161.9	20.3	-113.3	133.6
1.0	0	0	0	0	0	29.0	-188.6	20.3	-132.0	152.4	

9.7.9 Calculate Factored Moments – Service Limit State II

Using live load distribution factors in Table 9.7-6, factored moments for an interior girder at the Service Limit State II are calculated and listed in Table 9.7-13.

$$\text{Service II: } 1.0(DC) + 1.0(DW) + 1.30(DF)(LL+IM)_{HL-93}$$

**Table 9.7-13 Factored Moments for Interior Girder
– Service Limit State II**

Span	Point x/L	Dead Load			Live Load	
		<i>DC1</i>	<i>DC2</i>	<i>DW</i>	<i>(LL+IM)HL-93</i>	
		<i>M_DC1</i> (kip-ft)	<i>M_DC2</i> (kip-ft)	<i>M_DW</i> (kip-ft)	<i>+M</i> (kip-ft)	<i>-M</i> (kip-ft)
1	0.0	0	0	0	0	0
	0.1	693	57	135	1337	-291
	0.2	1144	94	223	2293	-583
	0.3	1353	111	264	2884	-874
	0.4	1329	108	258	3174	-1165
	0.5	1045	86	204	3161	-1457
	0.6	528	43	103	2890	-1749
	0.7	-231	-19	-45	2334	-2314
	0.8	-1232	-101	-240	1541	-2644
	0.9	-2474	-203	-483	684	-3075
1.0	-3959	-325	-772	572	-3768	
2	0.0	-3959	-325	-772	512	-3768
	0.1	-1555	-128	-303	668	-1982
	0.2	304	25	59	1659	-1006
	0.3	1619	133	316	2706	-877
	0.4	2389	196	466	3386	-786
	0.5	2615	215	510	3616	-761
	0.6	2297	188	448	3426	-927
	0.7	1434	118	280	2784	-1094
	0.8	26	2	5	1740	-1277
	0.9	-1926	-158	-376	673	-2166
1.0	-4422	-363	-862	377	-3863	
3	0.0	-4422	-363	-862	407	-3863
	0.1	-2574	-211	-502	648	-2887
	0.2	-1038	-85	-202	1601	-2425
	0.3	186	15	36	2536	-1834
	0.4	1097	90	214	3199	-1571
	0.5	1695	139	331	3543	-1309
	0.6	1981	162	386	3579	-1047
	0.7	1955	160	381	3268	-786
	0.8	1616	133	315	2602	-524
	0.9	964	79	188	1518	-262
1.0	0	0	0	0	0	

9.7.10 Design Composite Section in Positive Moment Region at 0.5 Point of Span 2

For midspan sections, design is normally governed by the bending moments. In following, only flexural design for 0.5 Point Section is illustrated. A similar shear design procedure is shown in Section 9.7.11.

9.7.10.1 Illustrate Calculations of Factored Moments – Strength Limit States

Factored force effects are calculated and summarized in Section 9.7.7. Table 9.7-14 illustrates detailed calculations for factored moments at 0.5 Point of Span 2.

Table 9.7-14 Factored Moments at 0.5 Point of Span 2

Load Type	Unfactored Moment (kip-ft)	Factored Moment (kip-ft)
<i>DC1</i>	2,615	$M_{DC1} = 1.25(2,615) = 3,269$ (applied to steel section alone)
<i>DC2</i>	215	$M_{DC2} = 1.25(215) = 269$ (applied to long-term composite section $3n = 24$)
<i>DW</i>	510	$M_{DW} = 1.5(510) = 765$ (applied to long-term composite section $3n = 24$)
$(LL+IM)_{HL-93}$	3,455 (one lane)	$M_{(LL+IM)_{HL-93}} = 1.75(0.805)(3,455) = 4,867$ (applied to short-term composite section $n = 8$)
$(LL+IM)_{P15}$	6,897 (one lane)	$M_{(LL+IM)_{P15}} = 1.35(0.805)(6,897) = 7,495$ (applied to short-term composite section $n = 8$)
Controlling <i>DC+DW+(LL+I M)</i>		$M_u = 3,269 + 269 + 765 + 7,495 = 11,798$
Strength I:	$1.25(DC) + 1.5(DW) + 1.75(DF)(LL+IM)_{HL-93}$	
Strength II:	$1.25(DC) + 1.5(DW) + 1.35(DF)(LL+IM)_{P15}$	

9.7.10.2 Calculate Elastic Section Properties

Determine Effective Flange Width

According to the CA 4.6.2.6, the effective flange width is dependent on the girder spacing to span length ratio (S/L). In this design example, $S = 12$ ft and $L = 165$ ft. For the interior girder in Span 2, the effective flange width is as:

$$\begin{aligned} \therefore S/L &= 12/165 = 0.073 < 0.32 \\ \therefore b_{eff} &= b = 12 \text{ ft} = 144 \text{ in.} \end{aligned} \quad \text{(CA 4.6.2.6.1-2)}$$

Calculate Elastic Section Properties

Elastic section properties for the steel section alone, the steel section and deck slab longitudinal reinforcement, the short-term composite section ($n = 8$), and the long-term composite section ($3n = 24$) are calculated and shown from Table 9.7-15 to 9.7-18.

Table 9.7-15 Properties of Steel Section Alone

Component	A_i (in. ²)	y_i (in.)	$A_i y_i$ (in. ³)	$y_i - y_{NCb}$ (in.)	$A_i (y_i - y_{NCb})^2$ (in. ⁴)	I_o (in. ⁴)
Top flange 18 × 1	18.00	80.25	1,444.5	45.05	36,531	1.5
Web 78 × 0.625	48.75	40.75	1,986.6	5.55	1,502	24,716
Bottom flange 18 × 1.75	31.50	0.875	27.6	-34.325	37,113	8.04
Σ	98.25	-	3,458.7	-	75,146	24,726

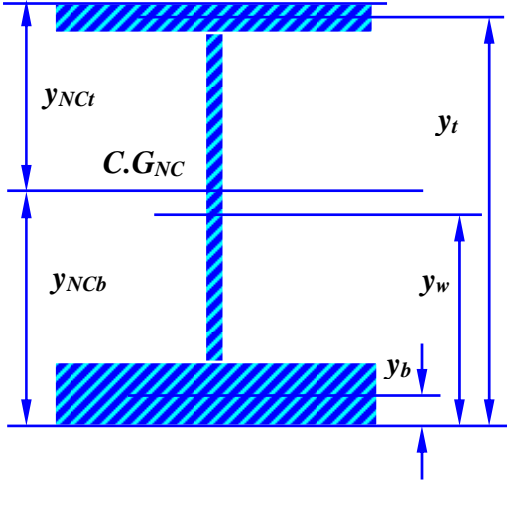

$$y_{NCb} = \frac{\sum A_i y_i}{\sum A_i} = \frac{3,458.7}{98.25} = 35.2 \text{ in.}$$

$$y_{NCt} = (1.75 + 78 + 1) - 35.2 = 45.55 \text{ in.}$$

$$I_{NC} = \sum I_o + \sum A_i (y_i - y_{NCb})^2$$

$$= 24,726 + 75,146 = 99,872 \text{ in.}^4$$

$$S_{NCb} = \frac{I_{NC}}{y_{NCb}} = \frac{99,872}{35.2} = 2,837 \text{ in.}^3$$

$$S_{NCt} = \frac{I_{NC}}{y_{NCt}} = \frac{99,872}{45.55} = 2,193 \text{ in.}^3$$

Properties of the steel section alone may be conservatively used for calculating stresses under negative moments. In this example, properties of the steel section and deck slab longitudinal reinforcement are used for calculating stresses due to negative moments (AASHTO 6.10.1.1.c). Assume the total area of longitudinal reinforcement in the deck slab is 1% of concrete deck slab area, we have A_s as follows:

$$A_s = 0.01(12 \times 12)(9.125) = 13.14 \text{ in.}^2$$

Table 9.7-16 Properties of Steel Section and Deck Slab Reinforcement

Component	A_i (in. ²)	y_i (in.)	$A_i y_i$ (in. ³)	$y_i - y_{NSb}$ (in.)	$A_i (y_i - y_{NSb})^2$ (in. ⁴)	I_o (in. ⁴)
Top Reinforcement	13.14	88.44	1162.1	46.96	28,977	0
Steel section	98.25	35.2	3,458.4	-6.28	3,875	99,872
Σ	111.39	-	4,620.5	-	32,852	99,872

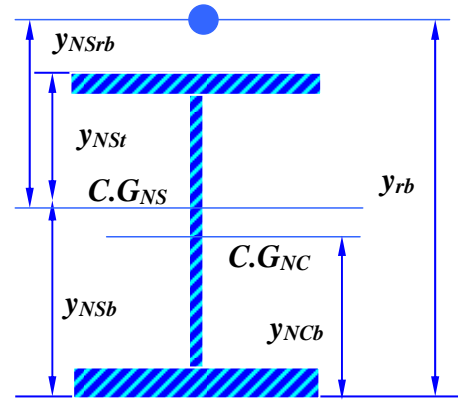

$$y_{NSb} = \frac{\sum A_i y_i}{\sum A_i} = \frac{4,620.5}{111.39} = 41.48 \text{ in.}$$

$$y_{NSr} = (1 + 78 + 1.75) - 41.48 = 39.27 \text{ in.}$$

$$y_{NSrb} = 88.44 - 41.48 = 46.96 \text{ in.}$$

$$I_{NS} = \sum I_o + \sum A_i (y_i - y_{NSb})^2 = 99,872 + 32,852 = 132,724 \text{ in.}^4$$

$$S_{NSb} = \frac{I_{NS}}{y_{NSb}} = \frac{132,724}{41.48} = 3,200 \text{ in.}^3$$

$$S_{NSr} = \frac{I_{NS}}{y_{NSr}} = \frac{132,724}{39.27} = 3,380 \text{ in.}^3$$

$$S_{NSrb} = \frac{I_{NS}}{y_{NSr}} = \frac{132,724}{46.96} = 2,826 \text{ in.}^3$$

Table 9.7-17 Properties of Short-term Composite Section ($n = 8$)

Component	A_i (in. ²)	y_i (in.)	$A_i y_i$ (in. ³)	$y_i - y_{STb}$ (in.)	$A_i (y_i - y_{STb})^2$ (in. ⁴)	I_o (in. ⁴)
Steel section	98.25	35.2	3,458.4	-33.31	109,014	99,872
Concrete Slab 144/8 × 9.125	164.25	88.44	14,526.3	19.93	65,241	1,140
Σ	262.5	-	17,984.7	-	174,255	101,012

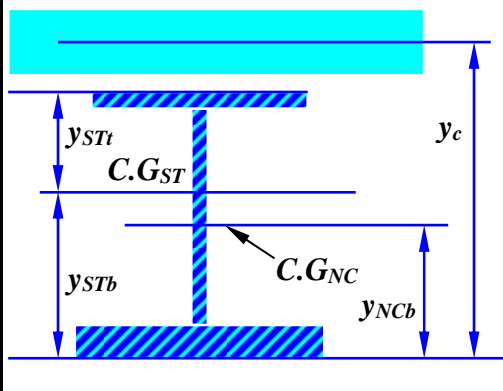

$$y_{STb} = \frac{\Sigma A_i y_i}{\Sigma A_i} = \frac{17,984.7}{262.5} = 68.51 \text{ in.}$$

$$y_{STt} = (1.75 + 78 + 1) - 68.51 = 12.24 \text{ in.}$$

$$I_{ST} = \Sigma I_o + \Sigma A_i (y_i - y_{STb})^2$$

$$= 101,012 + 174,255 = 275,267 \text{ in.}^4$$

$$S_{STb} = \frac{I_{ST}}{y_{STb}} = \frac{275,267}{68.51} = 4,018 \text{ in.}^3$$

$$S_{STt} = \frac{I_{ST}}{y_{STt}} = \frac{275,267}{12.24} = 22,489 \text{ in.}^3$$

Table 9.7-18 Properties of Long-term Composite Section ($3n = 24$)

Component	A_i (in. ²)	y_i (in.)	$A_i y_i$ (in. ³)	$y_i - y_{LTb}$ (in.)	$A_i (y_i - y_{LTb})^2$ (in. ⁴)	I_o (in. ⁴)
Steel section	98.25	35.2	3,458.4	-19.05	35,655	99,872
Concrete Slab 144/24 × 9.125	54.75	88.44	4,842.1	34.19	64,000	380
Σ	153	-	8,300.5	-	99,655	100,252

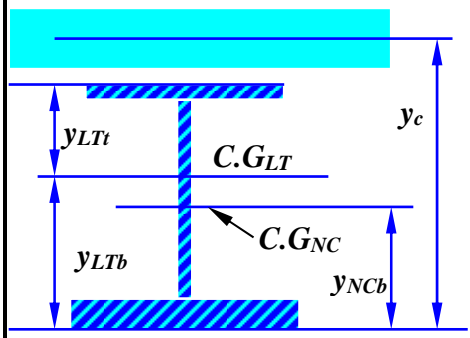

$$y_{LTb} = \frac{\Sigma A_i y_i}{\Sigma A_i} = \frac{8,300.5}{153} = 54.25 \text{ in.}$$

$$y_{LTt} = (1.75 + 78 + 1) - 54.25 = 26.5 \text{ in.}$$

$$I_{LT} = \Sigma I_o + \Sigma A_i (y_i - y_{LTb})^2$$

$$= 100,252 + 99,655 = 199,907 \text{ in.}^4$$

$$S_{LTb} = \frac{I_{LT}}{y_{LTb}} = \frac{199,907}{54.25} = 3,685 \text{ in.}^3$$

$$S_{LTt} = \frac{I_{LT}}{y_{LTt}} = \frac{199,907}{26.5} = 7,544 \text{ in.}^3$$

It should be pointed out that the concrete haunch is ignored in calculating composite section properties.

9.7.10.3 Design for Flexure – Strength Limit State

General Requirement

At the strength limit state, the composite compact section in positive moment regions shall satisfy the requirement as follows:

$$M_u + \frac{1}{3}f_l S_{xt} \leq \phi_f M_n \quad (\text{AASHTO 6.10.7.1.1-1})$$

In this example of the straight bridge, flange lateral bending stress for interior girders $f_l = 0$. The design equation, therefore, is simplified as follows:

$$M_u \leq \phi_f M_n$$

Check Section Compactness

For composite sections in the positive moment region, it is usually assumed that the top flange is adequately braced by the hardened concrete deck. There is no requirement for the compression flange slenderness and bracing for compact composite sections at the strength limit state. Three requirements (AASHTO 6.10.6.2.2) for a compact composite section in straight bridges are checked as follows:

Specified minimum yield strength of flanges:

$$F_{yf} = 50 \text{ ksi} < 70 \text{ ksi} \quad \text{O.K.} \quad (\text{AASHTO 6.10.6.2.2})$$

$$\text{Web:} \quad \frac{D}{t_w} = 124.8 < 150 \quad \text{O.K.} \quad (\text{AASHTO 6.10.2.1.1-1})$$

$$\text{Section:} \quad \frac{2D_{cp}}{t_w} \leq 3.76 \sqrt{\frac{E}{F_{yc}}} \quad (\text{AASHTO 6.10.6.2.2-1})$$

where D_{cp} is depth of the web in compression at the plastic moment state and is determined in the following.

Compressive force in concrete slab:

$$P_s = 0.85f'_c b_{eff} t_s = 0.85(3.6)(144)(9.125) = 4,021 \text{ kips}$$

in which t_s is thickness of concrete slab

Yield force in the top compression flange:

$$P_c = A_{fc} F_{yc} = (18 \times 1)(50) = 900 \text{ kips}$$

Yield force in the web:

$$P_w = A_w F_{yw} = (78 \times 0.625)(50) = 2,438 \text{ kips}$$

Yield force in the bottom tension flange:

$$P_t = A_{ft} F_{yt} = (18 \times 1.75)(50) = 1,575 \text{ kips}$$

$$\therefore P_s + P_c = 4,021 + 900 = 4,921 \text{ kips} > P_w + P_t = 2,438 + 1,575 = 4,013 \text{ kips}$$

\therefore Plastic neutral axis is within the top compression flange and D_{cp} is equal to zero.

$$\frac{2D_{cp}}{t_w} = 0.0 < 3.76 \sqrt{\frac{E}{F_{yc}}} \quad \text{O.K.} \quad (\text{AASHTO 6.10.6.2.2-1})$$

The nominal flexural resistance, M_n , of the composite compact section is, therefore, computed in accordance with AASHTO 6.10.7.1.2.

Calculate Plastic Moment M_p

At the plastic moment state, the compressive stress in the concrete slab of a composite section is assumed equal to $0.85 f'_c$, and tensile stress in the concrete slab is neglected. The stress in reinforcement and steel girder section is assumed equal to F_y . The reinforcement in the concrete slab is neglected in this example. The plastic moment M_p is determined using equilibrium equations and is the first moment of all forces about the plastic neutral axis (AASHTO D6.1).

Determine Location of Plastic Neutral Axis (PNA)

As calculated above, the plastic neutral axis (PNA) is within the top flange of steel girder. Denote that \bar{y} is the distance from the top of the compression flange to the PNA as shown in Figure 9.7-7, we obtain:

$$P_s + P_{c1} = P_{c2} + P_w + P_t$$

where

$$P_{c1} = \bar{y} b_{fc} F_{yc}$$

$$P_{c2} = (t_{fc} - \bar{y}) b_{fc} F_{yc}$$

in which b_{fc} and t_{fc} are width and thickness of top flange of steel section, respectively; F_{yc} is yield strength of top compression flange of steel section.

Substituting above expressions into the equilibrium equation for \bar{y} , obtain

$$\bar{y} = \frac{t_{fc}}{2} \left(\frac{P_w + P_t - P_s}{P_c} + 1 \right)$$

$$\bar{y} = \frac{1}{2} \left(\frac{2,438 + 1,575 - 4,021}{900} + 1 \right) = 0.496 \text{ in.} < t_{fc} = 1.0 \text{ in.} \quad \text{O.K.}$$

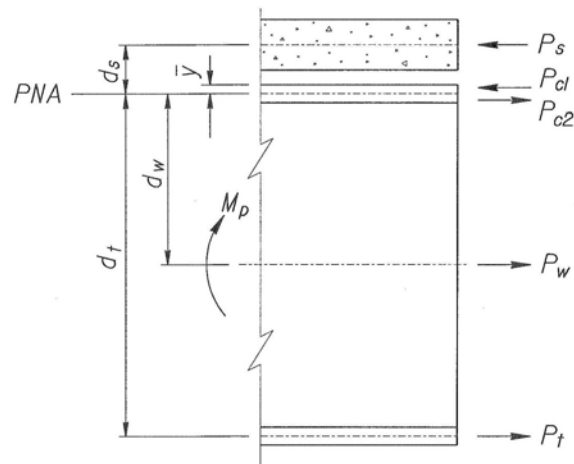

Figure 9.7-7 Plastic Moment Capacity State

Calculate Plastic Moment M_p

Summing all forces about the PNA, obtain:

$$\begin{aligned}
 M_p = \sum M_{PNA} &= P_s d_s + P_{c1} \left(\frac{\bar{y}}{2} \right) + P_{c2} \left(\frac{t_{cf} - \bar{y}}{2} \right) + P_w d_w + P_t d_t \\
 &= P_s d_s + b_{fc} F_{yc} \left(\frac{(\bar{y})^2 + (t_{cf} - \bar{y})^2}{2} \right) + P_w d_w + P_t d_t
 \end{aligned}$$

where

$$d_s = \frac{9.125}{2} + 4.125 - 1 + 0.496 = 8.18 \text{ in.}$$

$$d_w = \frac{78}{2} + 1 - 0.496 = 39.50 \text{ in.}$$

$$d_t = \frac{1.75}{2} + 78 + 1 - 0.496 = 79.38 \text{ in.}$$

$$\begin{aligned}
 M_p &= (4,021)(8.18) + (18)(50) \left(\frac{0.496^2 + (1 - 0.496)^2}{2} \right) \\
 &\quad + (2,438)(39.5) + (1,575)(79.38) \\
 &= 254,441 \text{ kip-in.} = 21,203 \text{ kip-ft}
 \end{aligned}$$

Calculate Yield Moment M_y

The yield moment M_y corresponds to the first yielding of either steel flange. It is obtained by the following formula (AASHTO D6.2):

$$M_y = M_{D1} + M_{D2} + M_{AD} \quad (\text{AASHTO D6.2.2-2})$$

From Section 9.7.10.1, factored moments, M_{D1} and M_{D2} are as follows:

$$M_{D1} = M_{DC1} = 3,269 \text{ kip-ft}$$

$$M_{D2} = M_{DC2} + M_{DW} = 269 + 765 = 1,034 \text{ kip-ft}$$

Using section moduli S_{NC} , S_{ST} and S_{LT} as shown in Section 9.7.10.2 for the non-composite steel, the short-term and the long-term composite section, we have:

$$M_{AD} = S_{ST} \left(F_y - \frac{M_{D1}}{S_{NC}} - \frac{M_{D2}}{S_{LT}} \right)$$

For the top flange:

$$M_{AD} = (22,489) \left(50 - \frac{3,269(12)}{2,193} - \frac{1,034(12)}{7,544} \right)$$

$$= 685,182 \text{ kip-in.} = 57,099 \text{ kip-ft}$$

For the bottom flange:

$$M_{AD} = (4,018) \left(50 - \frac{3,269(12)}{2,837} - \frac{1,034(12)}{3,685} \right) \quad (\text{Control})$$

$$= 131,813 \text{ kip-in.} = 10,984 \text{ kip-ft}$$

$$\therefore M_y = 3,269 + 1,034 + 10,984 = 15,287 \text{ kip-ft}$$

Calculate Flexural Resistance

In this example, it is assumed that the adjacent interior-bent sections are non-compact non-composite sections that do not satisfy requirements of AASHTO B6.2. The nominal flexural resistance of the composite compact section in positive flexure is calculated in accordance with AASHTO and CA 6.10.7.1.2:

$$M_n = \min \begin{cases} M_p & \text{for } D_p \leq 0.1D_t \\ M_p \left[1 - \left(1 - \frac{M_y}{M_p} \right) \left(\frac{D_p / D_t - 0.1}{0.32} \right) \right] & \text{for } D_p > 0.1D_t \\ 1.3 R_h M_y & \text{for a continuous span} \end{cases}$$

(AASHTO and CA 6.10.7.1.2-1,2, 3)

where R_h is hybrid factor (AASHTO 6.10.1.10.1) and equal to 1.0 for this example; D_p is the depth from the top of the concrete deck to the PNA; D_t is total depth of the composite section.

The compact and noncompact sections shall satisfy the following ductility requirement to ensure that the tension flange of the steel section reaches significant yielding before the crushing strain is reached at the top of concrete deck.

$$D_p \leq 0.42D_t \quad (\text{AASHTO 6.10.7.3-1})$$

$$D_p = 13.25 - 1 + 0.496 = 12.75 \text{ in.}$$

$$D_t = 1.75 + 78 + 13.25 = 93 \text{ in.}$$

$$D_p = 12.75 \text{ in.} < 0.42D_t = 0.42(93) = 39.06 \text{ in.} \quad \text{O.K.}$$

$$D_p = 12.75 \text{ in.} > 0.1D_t = 9.3 \text{ in.}$$

$$\begin{aligned} M_n &= \left[1 - \left(1 - \frac{M_y}{M_p} \right) \left(\frac{D_p / D_t - 0.1}{0.32} \right) \right] M_p \\ &= \left[1 - \left(1 - \frac{15,287}{21,203} \right) \left(\frac{12.75/93 - 0.1}{0.32} \right) \right] (21,203) = 20,517 \text{ kip-ft} \\ &> 1.3R_h M_y = (1.3)(1.0)(15,287) = 19,873 \text{ kip-ft} \end{aligned}$$

Use $M_n = 19,873 \text{ kip-ft}$

Check Design Requirement

$$M_u = 11,798 \text{ kip-ft} < \phi_f M_n = (1.0)(19,873) = 19,873 \text{ kip-ft} \quad \text{OK.}$$

(AASHTO 6.10.7.1.1-1)

9.7.10.4 Illustrate Calculations of Fatigue Moment Ranges

Fatigue moment ranges are calculated and summarized in Section 9.7.8. For 0.5 Point of Span 2, using live load distribution factor $DF_m = 0.433$ (Table 9.7.7), fatigue moment ranges are as follows:

Fatigue I:

$$M = \gamma(DF_m)(LL+IM)_{HL} = (1.75)(0.433)(LL+IM)_{HL-93}$$

$$+M = (1.75)(0.433)(1,715) = 1,299 \text{ kip-ft}$$

$$-M = (1.75)(0.433)(-302) = -229 \text{ kip-ft}$$

Fatigue II:

$$M = \gamma(DF_m)(LL+IM)_{P9} = (1.0)(0.433)(LL+IM)_{P9}$$

$$+M = (1.0)(0.433)(5,144) = 2,227 \text{ kip-ft}$$

$$-M = (1.0)(0.433)(-933) = -404 \text{ kip-ft}$$

9.7.10.5 Check Typical Girder Details – Fatigue Limit States

For load-induced fatigue consideration, the most common types of details in a typical plate girder are (AASHTO Table 6.6.1.2.3-1) listed in Table 6.8-1 and nominal fatigue resistance for those typical details are shown in Table 6.8-2 in Chapter 6.

For a section in the positive moment region within mid-span, such as the section at 0.5 Point of Span 2, flexural behavior usually dominates the design. Positive live load moments are applied to the short-term composite section and negative live load moments are applied to the steel section and deck slab longitudinal reinforcement (AASHTO 6.10.1.1.1c). Fatigue stress ranges at the bottom flanges and the top flanges are checked as follows:

Fatigue I - HL-93 Truck for Infinite Life:

Flexural fatigue stress ranges at the bottom flange:

$$\begin{aligned} \gamma(\Delta f) &= \left| \frac{+M}{S_{STb}} \right| + \left| \frac{-M}{S_{NCb}} \right| = \frac{1,299(12)}{4,018} + \frac{229(12)}{3,200} \\ &= 3.88 + 0.86 = 4.74 \text{ ksi} < 12.0 \text{ ksi O.K. for Category C'} \\ & < 16.0 \text{ ksi O.K. for Category B} \end{aligned}$$

Flexural fatigue stress ranges at the top flange:

$$\begin{aligned} \gamma(\Delta f) &= \left| \frac{+M}{S_{STt}} \right| + \left| \frac{-M}{S_{NCt}} \right| = \frac{1,299(12)}{22,489} + \frac{229(12)}{3,380} \\ &< 10.0 \text{ ksi O.K. for Category C} \\ &= 0.69 + 0.81 = 1.50 \text{ ksi} < 12.0 \text{ ksi O.K. for Category C'} \\ &< 16.0 \text{ ksi O.K. for Category B} \end{aligned}$$

Fatigue II - P-9 Truck for Finite Life:

Flexural fatigue stress ranges at the bottom flange:

$$\begin{aligned} \gamma(\Delta f) &= \left| \frac{+M}{S_{STb}} \right| + \left| \frac{-M}{S_{NCb}} \right| = \frac{2,227(12)}{4,018} + \frac{404(12)}{3,200} \\ &= 6.65 + 1.52 = 8.17 \text{ ksi} < 21.58 \text{ ksi O.K. for Category C'} \\ &< 30.15 \text{ ksi O.K. for Category B} \end{aligned}$$

Flexural fatigue stress ranges at the top flange:

$$\begin{aligned} \gamma(\Delta f) &= \left| \frac{+M}{S_{STI}} \right| + \left| \frac{-M}{S_{NCI}} \right| = \frac{2,227(12)}{22,489} + \frac{404(12)}{3,380} \\ &< 21.58 \text{ ksi O.K. for Category C} \\ &= 1.19 + 1.43 = 2.62 \text{ ksi} < 21.58 \text{ ksi O.K. for Category C'} \\ &< 30.15 \text{ ksi O.K. for Category B} \end{aligned}$$

9.7.10.6 Check Requirements - Service Limit State

General Requirements

Service Limit State II is to control the elastic and permanent deflections under the design live load HL-93 (AASHTO 6.10.4). Live load deflection Δ may not exceed $L/800$ (AASHTO 2.5.2.6.2) and is calculated and checked in Section 9.7.16.

Illustrate Calculations of Factored Moments - Service Limit State II

It is noted that for unshored construction, $DC1$, $DC2+DW$, and live load are applied to the non-composite (steel section alone), long-term and short-term composite sections, respectively. Factored moments at the Service Limit State II are calculated and summarized in Table 9.7.13. The calculation of factored moments for 0.5 Point of Span 2 are illustrated as follows:

$$\begin{aligned} M_{DC1} &= 2,615 \text{ kip-ft} && \text{(applied to steel section alone)} \\ M_{DC2} + M_{DW} &= 215 + 510 = 725 \text{ kip-ft} && \text{(applied to long-term composite section)} \\ M_{(LL+IM)HL-93} &= (1.3)(0.805)(3,455) \\ &= 3,616 \text{ kip-ft} && \text{(applied to short-term composite section)} \end{aligned}$$

Check Flange Stresses

In this example, $f_i = 0$ for this interior girder. The requirement becomes:

$$\begin{aligned} f_f &= \frac{M_{DC1}}{S_{NC}} + \frac{M_{DC2} + M_{DW}}{S_{LT}} + \frac{M_{(LL+IM)HL-93}}{S_{ST}} \leq 0.95R_h F_{yf} \\ &= 0.95(1.0)(50) = 47.5 \text{ ksi} \end{aligned}$$

- For the top flange

$$f_f = \frac{(2615)(12)}{2,193} + \frac{(725)(12)}{7,544} + \frac{(3,616)(12)}{22,489}$$

$$= 14.31 + 1.15 + 1.93 = 17.39 \text{ ksi} < 47.5 \text{ ksi}$$

O.K. (AASHTO 6.10.4.2.2-1)

- For the bottom flange

$$f_f = \frac{(2615)(12)}{2,837} + \frac{(725)(12)}{3,685} + \frac{(3,616)(12)}{4,018}$$

$$= 11.06 + 2.36 + 10.80 = 24.22 \text{ ksi} < 47.5 \text{ ksi}$$

O.K. (AASHTO 6.10.4.2.2-2)

- For the compression flange

AASHTO 6.10.4.2.2 states that for composite sections in positive flexure in which the web satisfies the requirement of AASHTO 6.10.2.1.1, i.e., $D/t_w \leq 150$, satisfying AASHTO 6.10.4.2.2-4 is not required. In this example,

$$\frac{D}{t_w} = \frac{78}{0.625} = 124.8 < 150 \quad (\text{AASHTO 6.10.2.1.1-1})$$

∴ The compression flange check is not required.

9.7.10.7 Check Requirements - Constructibility

General Requirements

At construction stages, steel girders of Span 2 with an unbraced compression flange length $L_b = 330$ in. carry out the construction load including dead load (self-weight of steel girders and concrete deck slab) and other loads acting on the structure during construction. To prevent nominal yielding or reliance on post-buckling resistance of the steel girder during critical stages of construction, the following AASHTO 6.10.3 requirements for flexural stresses are checked. For 0.5 Point Section, shear effects are very small and shear strength check is not illustrated. A similar design procedure is shown in Section 9.7.11.

Calculate Factored Moment – Constructibility

In the constructibility check, all loads shall be factored as specified in AASHTO 3.4.2. In this example, no other construction load is assumed and only factored dead loads are applied on the noncomposite section. The compression flange is discretely braced with an unbraced length $L_b = 330$ in. within Span 2. The factored moment at 0.5 Point of Span 2 is:

$$M_u = M_{DC1} = 1.25(2,615) = 3,269 \text{ kip-ft}$$

Check Compression Flange

- Web Compactness

Limiting slenderness ratio for a noncompact web:

$$\lambda_{rw} = 5.7 \sqrt{\frac{E}{F_{yc}}} = 5.7 \sqrt{\frac{29,000}{50}} = 137.3 \quad (\text{AASHTO 6.10.1.10.2-4})$$

$$D_c = y_{NCt} - t_{fc} = 45.55 - 1.0 = 44.55 \quad (\text{See Table 9.7-15})$$

$$\therefore \frac{2D_c}{t_w} = \frac{2(44.55)}{(0.625)} = 142.6 > \lambda_{rw} = 137.3$$

The web is slender, and AASHTO Equations 6.10.3.2.1-2 and 6.10.3.2.1-3 shall be checked.

- Calculate Flange-Strength Reduction Factors R_h and R_b

Since homogenous plate girder sections are used for this example, hybrid factor R_h is taken as 1.0 (AASHTO 6.10.1.10.1).

When checking constructibility according to AASHTO 6.10.3.2, web load-shedding factor R_b is taken as 1.0 (AASHTO 6.10.1.10.2).

- Calculate Flexural Resistance

Nominal flexural resistance of the compression flange is the smaller of the local buckling resistance (AASHTO 6.10.8.2.2) and the lateral torsional buckling resistance (AASHTO 6.10.8.2.3)

Local buckling resistance

$$\therefore \lambda_f = \frac{b_{fc}}{2t_{fc}} = \frac{18}{2(1)} = 9 < \lambda_{pf} = 0.38 \sqrt{\frac{E}{F_{yc}}} = 0.38 \sqrt{\frac{29,000}{50}} = 9.15$$

$$F_{nc(FLB)} = R_b R_h F_{yc} = (1.0)(1.0)(50) = 50 \text{ ksi} \quad (\text{AASHTO 6.10.8.2.2-1})$$

Lateral torsional buckling resistance

$$r_t = \frac{b_{fc}}{\sqrt{12 \left(1 + \frac{1}{3} \frac{D_c t_w}{b_{fc} t_{fc}} \right)}} = \frac{18}{\sqrt{12 \left(1 + \frac{1}{3} \frac{(44.55)(0.625)}{(18)(1.0)} \right)}} = 4.22 \text{ in.}$$

(AASHTO 6.10.8.2.3-9)

$$L_p = 1.0 r_t \sqrt{\frac{E}{F_{yc}}} = (1.0)(4.22) \sqrt{\frac{29,000}{50}} = 101.6 \text{ in.}$$

$$F_{yr} = \text{smaller} \left\{ \begin{array}{l} 0.7 F_{yc} = (0.7)(50) \\ F_{yw} = 50 \end{array} \right\} = 35 \text{ ksi} > 0.5 F_{yc} = 25 \text{ ksi}$$

Use $F_{yr} = 35 \text{ ksi}$

$$L_r = \pi r_t \sqrt{\frac{E}{F_{yr}}} = (\pi)(4.22) \sqrt{\frac{29,000}{35}} = 381.6 \text{ in.} \quad (\text{AASHTO 6.10.8.2.3-5})$$

$$\therefore L_p = 101.6 \text{ in.} < L_b = 330 \text{ in.} < L_r = 381.6 \text{ in.}$$

$$\begin{aligned} F_{nc(LTB)} &= C_b \left[1 - \left(1 - \frac{F_{yr}}{R_h F_{yc}} \right) \left(\frac{L_b - L_p}{L_r - L_p} \right) \right] R_b R_h F_{yc} \\ &= (1.0) \left[1 - \left(1 - \frac{35}{(1.0)(50)} \right) \left(\frac{330 - 101.6}{381.6 - 101.6} \right) \right] (1.0)(1.0)(50) \\ &= 37.8 \text{ ksi} < R_b R_h F_{yc} = (1.0)(1.0)(50) = 50 \text{ ksi} \end{aligned}$$

(AASHTO 6.10.8.2.3-2)

Use $F_{nc(LTB)} = 37.8 \text{ ksi}$

It should be pointed out that C_b factor is taken as 1.0 conservatively for 0.5 Point of Span 2. The nominal flexural resistance of the compression flange is:

$$F_{nc} = \min (F_{nc(FLB)}, F_{nc(LTB)}) = \min (50, 37.8) = 37.8 \text{ ksi}$$

$$\begin{aligned} f_{bu} &= \frac{M_u}{S_{NCt}} = \frac{3,269(12)}{2,193} = 17.9 \text{ ksi} && \text{O.K.} && (\text{AASHTO 6.10.3.2.1-2}) \\ &< \phi_f F_{nc} = 37.8 \text{ ksi} \end{aligned}$$

Calculate Web Bend-buckling Resistance

$$k = 9 \left(\frac{D}{D_c} \right)^2 = 9 \left(\frac{78}{44.55} \right)^2 = 27.59 \quad (\text{AASHTO 6.10.1.9.1-2})$$

$$F_{crw} = \frac{0.9 E k}{\left(\frac{D}{t_w} \right)^2} = \frac{0.9(29,000)(27.59)}{\left(\frac{78}{0.625} \right)^2} = 46.2 \text{ ksi}$$

$$< \text{smaller} \left\{ \begin{array}{l} R_h F_{yc} = (1.0)(50) = 50 \text{ ksi} \\ F_{yw} / 0.7 = 50 / 0.7 = 71.4 \text{ ksi} \end{array} \right\} = 50 \text{ ksi}$$

(AASHTO 6.10.1.9.1-1)

Use $F_{crw} = 46.2 \text{ ksi}$

$$f_{bu} = 17.9 \text{ ksi} < \phi_f F_{crw} = 46.2 \text{ ksi} \quad \text{O.K.} \quad (\text{AASHTO 6.10.3.2.1-3})$$

Check Tension Flange

$$f_{bu} = \frac{M_u}{S_{NCb}} = \frac{3,269(12)}{2,837} = 13.8 \text{ ksi} < \phi_f R_h F_{yt} = 50 \text{ ksi}$$

O.K. (AASHTO 6.10.3.2.2-1)

9.7.11 Design Noncomposite Section in Negative Moment Region at Bent 3

In this example, steel girder sections in negative moment regions are designed as noncomposite sections. When shear connectors are provided in negative moment regions according to AASHTO 6.10.10, sections are considered as composite sections.

9.7.11.1 Illustrate Calculations of Factored Moments and Shears – Strength Limit States

Factored moments and shears are calculated and summarized in Section 9.7.7. Tables 9.7-19 and 9.7-20 illustrate detailed calculations for the section at Bent 3.

Table 9.7-19 Factored Moments at Section of Bent 3

Load Type	Unfactored Moment (kip-ft)	Factored Moment (kip-ft)
<i>DC1</i>	-4,422	$M_{DC1} = 1.25(-4,422) = -5,527.5$
<i>DC2</i>	-363	$M_{DC2} = 1.25(-363) = -453.8$
<i>DW</i>	-862	$M_{DW} = 1.5(-862) = -1,293.0$
<i>(LL+IM)HL-93</i>	-3,563 (one lane)	$M_{(LL+IM)HL-93} = 1.75(0.834)(-3,563)$ $= -5,200.2$
<i>(LL+IM)P15</i>	-5,981 (one lane)	$M_{(LL+IM)P15} = 1.35(0.834)(-5,981) = -6,734.0$
Controlling <i>DC+DW+(LL+IM)</i>		$M_u = -5,527.5 + (-453.8) + (-1,293.0) + (-6,734.0)$ $= -14,008$
Strength I:	$1.25(DC) + 1.5(DW) + 1.75(DF)(LL+IM)_{HL-93}$	
Strength II:	$1.25(DC) + 1.5(DW) + 1.35(DF)(LL+IM)_{P15}$	

Table 9.7-20 Factored Shears at Section of Bent 3

Load Type	Unfactored Shear (kip)	Factored Shear (kip)
<i>DC1</i>	-167.8	$V_{DC1} = 1.25(-167.8) = -209.75$
<i>DC2</i>	-13.8	$V_{DC2} = 1.25(-13.8) = -17.25$
<i>DW</i>	-32.7	$V_{DW} = 1.5(-32.7) = -49.05$
<i>(LL+IM)HL-93</i>	-147.2 (one lane)	$V_{(LL+IM)HL-93} = 1.75(1.082)(-147.2) = -278.72$
<i>(LL+IM)P15</i>	-321.0 (one lane)	$V_{(LL+IM)P15} = 1.35(1.082)(-321.0) = -468.89$
Controlling <i>DC+DW+(LL+IM)</i>		$V_u = -209.75 + (-17.25) + (-49.05) + (-468.89)$ $= -745.0$

9.7.11.2 Calculate Elastic Section Properties

In order to calculate the stresses, deflection, and camber for this continuous composite girder, the elastic section properties for the steel section alone, the steel section and the deck slab longitudinal reinforcement, the short-term composite section, and the long-term composite section are calculated in Tables 9.7-21, 9.7-22, 9.7-23 and 9.7-24, respectively.

Table 9.7-21 Properties of Steel Section Alone

Component	A_i (in. ²)	y_i (in.)	$A_i y_i$ (in. ³)	$y_i - y_{NCb}$ (in.)	$A_i (y_i - y_{NCb})^2$ (in. ⁴)	I_o (in. ⁴)
Top flange 18 × 2	36.0	81.0	2,916.0	40.0	57,600	12
Web 78 × 0.625	48.75	41.0	1,998.75	0	0	24,716
Bottom flange 18 × 2	36.0	1.0	36.0	-40.0	57,600	12
Σ	120.75	-	4,950.75	-	115,200	24,740

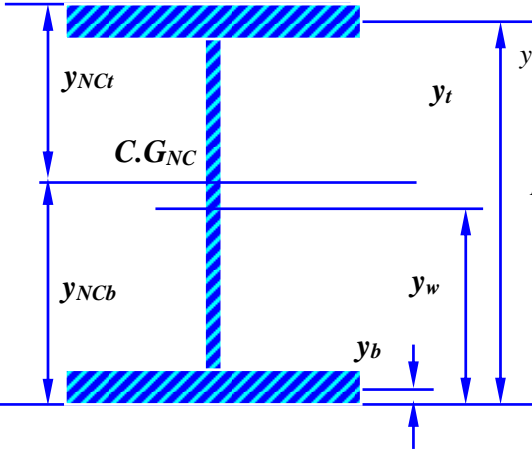

$$y_{NCb} = \frac{\sum A_i y_i}{\sum A_i} = \frac{4,950.75}{120.75} = 41.0 \text{ in.}$$

$$y_{NCt} = (2 + 78 + 2) - 41.0 = 41.0 \text{ in.}$$

$$I_{NC} = \sum I_o + \sum A_i (y_i - y_{NCb})^2$$

$$= 24,740 + 115,200 = 139,940 \text{ in.}^4$$

$$S_{NCb} = \frac{I_{NC}}{y_{NCb}} = \frac{139,940}{41.0} = 3,413 \text{ in.}^3$$

$$S_{NCt} = \frac{I_{NC}}{y_{NCt}} = \frac{139,940}{41.0} = 3,413 \text{ in.}^3$$

Assuming the total area of longitudinal reinforcement is 1% of the concrete area at the interior supports, $A_s = 0.01(12 \times 12)(9.125) = 13.14 \text{ in.}^2$, elastic section properties of the steel section and deck slab longitudinal reinforcement are calculated in Table 9.7-22 as follows.

Table 9.7-22 Properties of Steel Section and Deck Slab Reinforcement

Component	A_i (in. ²)	y_i (in.)	$A_i y_i$ (in. ³)	$y_i - y_{NSb}$ (in.)	$A_i (y_i - y_{NSb})^2$ (in. ⁴)	I_o (in. ⁴)
Top reinforcement	13.14	88.69	1,165.4	43.01	24,307	0
Steel section	120.75	41.0	4,950.8	-4.68	2,645	139,940
Σ	133.89	-	6,116.15	-	26,952	139,940

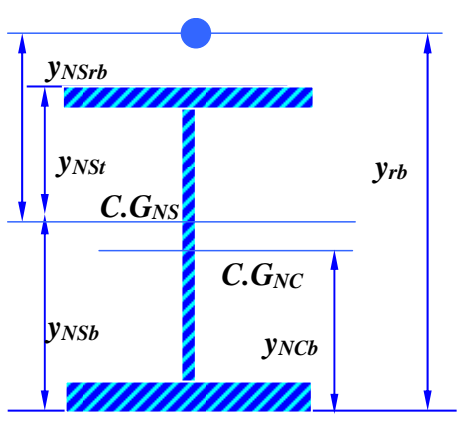

$$y_{NSb} = \frac{\sum A_i y_i}{\sum A_i} = \frac{6,116.15}{133.89} = 45.68 \text{ in.}$$

$$y_{NSt} = (2 + 78 + 2) - 45.68 = 36.32 \text{ in.}$$

$$y_{NSrb} = 88.69 - 45.68 = 43.01 \text{ in.}$$

$$I_{NS} = \sum I_o + \sum A_i (y_i - y_{NSb})^2$$

$$= 139,940 + 26,952 = 166,892 \text{ in.}^4$$

$$S_{NSb} = \frac{I_{NS}}{y_{NSb}} = \frac{166,892}{45.68} = 3,654 \text{ in.}^3$$

$$S_{NSt} = \frac{I_{NS}}{y_{NSt}} = \frac{166,892}{36.32} = 4,595 \text{ in.}^3$$

$$S_{NSrb} = \frac{I_{NS}}{y_{NSrb}} = \frac{166,892}{43.01} = 3,880 \text{ in.}^3$$

Table 9.7-23 Properties of Short-term Composite Section ($n = 8$)

Component	A_i (in. ²)	y_i (in.)	$A_i y_i$ (in. ³)	$y_i - y_{STb}$ (in.)	$A_i (y_i - y_{STb})^2$ (in. ⁴)	I_o (in. ⁴)
Steel section	120.75	41.0	4,950.8	-27.48	91,184	139,940
Concrete slab 144/8 × 9.125	164.25	88.69	14,567.3	20.21	67,087	1,140
Σ	285.0	-	19,518.1	-	158,271	141,080

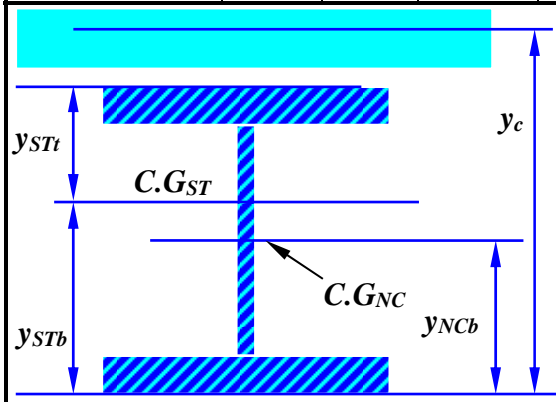

$$y_{STb} = \frac{\sum A_i y_i}{\sum A_i} = \frac{19,518.1}{285.0} = 68.48 \text{ in.}$$

$$y_{STt} = (2 + 78 + 2) - 68.48 = 13.52 \text{ in.}$$

$$I_{ST} = \sum I_o + \sum A_i (y_i - y_{STb})^2$$

$$= 141,080 + 158,271 = 299,351 \text{ in.}^4$$

$$S_{STb} = \frac{I_{ST}}{y_{STb}} = \frac{299,351}{68.48} = 4,371 \text{ in.}^3$$

$$S_{STt} = \frac{I_{ST}}{y_{STt}} = \frac{299,351}{13.52} = 22,141 \text{ in.}^3$$

Table 9.7-24 Properties of Long-term Composite Section (3n = 24)

Component	A_i (in. ²)	y_i (in.)	$A_i y_i$ (in. ³)	$y_i - y_{LTb}$ (in.)	$A_i (y_i - y_{LTb})^2$ (in. ⁴)	I_o (in. ⁴)
Steel section	120.75	41	4,950.8	-14.88	26,736	139,940
Concrete slab 144/24 × 9.125	54.75	88.69	4,855.8	32.81	58,938	380
Σ	175.5	-	9,806.6	-	85,674	140,320

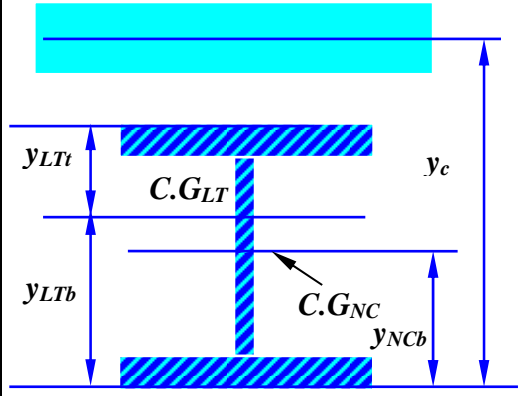

$$y_{LTb} = \frac{\sum A_i y_i}{\sum A_i} = \frac{9,806.6}{175.5} = 55.88 \text{ in.}$$

$$y_{STt} = (2 + 78 + 2) - 55.88 = 26.12 \text{ in.}$$

$$I_{ST} = \sum I_o + \sum A_i (y_i - y_{LTb})^2$$

$$= 140,320 + 85,674 = 225,994 \text{ in.}^4$$

$$S_{LTb} = \frac{I_{LT}}{y_{LTb}} = \frac{225,994}{55.88} = 4,044 \text{ in.}^3$$

$$S_{LTt} = \frac{I_{LT}}{y_{LTt}} = \frac{225,994}{26.12} = 8,652 \text{ in.}^3$$

It should be pointed out that the concrete haunch is ignored in calculating composite section properties.

9.7.11.3 Design for Flexure - Strength Limit States

General Requirements

For composite I-sections in negative flexure and non-composite I-sections with compact or non-compact webs in straight bridges, it is strongly recommended to use provisions in AASHTO Appendix A6. In this example of the straight bridge, flange lateral bending stress for interior girders $f_l = 0$. The design equations, therefore, are simplified as follows:

$$M_u \leq \phi_f M_{nc}$$

$$M_u \leq \phi_f M_{nt}$$

Check Section Compactness

Three requirements for noncompact sections are checked as follows:

Specified minimum yield strength of the flanges and web:

$$F_y \leq 70 \text{ ksi} \qquad \text{(AASHTO A6.1)}$$

$$\text{Web: } \frac{2D_c}{t_w} = \frac{78}{0.625} = 124.8 < \lambda_{rw} = 5.7 \sqrt{\frac{E}{F_{yc}}} = 5.7 \sqrt{\frac{29,000}{50}} = 137.3 \quad (\text{AASHTO A6.1-1})$$

$$\text{Flange ratio: } \frac{I_{yc}}{I_{yt}} = \frac{(2)(18)^3 / 12}{(2)(18)^3 / 12} = 1.0 > 0.3 \quad (\text{AASHTO A6.1-2})$$

Since the section at Bent 3 is noncompact, nominal flexural resistance of the I-section is calculated in accordance with AASHTO Appendix A6. It is the smaller of the local buckling resistance (AASHTO A6.3.2) and the lateral torsional buckling resistance (AASHTO A6.3.3).

Calculate Flange-Strength Reduction Factors R_h and R_b

Since homogenous plate girder sections are used for this example, hybrid factor R_h is taken as 1.0 (AASHTO 6.10.1.10.1). As shown above, the web is noncompact and web load-shedding factor R_b is taken as 1.0 (AASHTO 6.10.1.10.2).

Calculate Flexural Resistance – Based on Compression Flange

Nominal flexural resistance based on the compression flange is the smaller of the local buckling resistance (AASHTO A6.3.2) and the lateral torsional buckling resistance (AASHTO A6.3.3).

- *Calculate Local Buckling Resistance*

$$\therefore \lambda_f = \frac{b_{fc}}{2t_{fc}} = \frac{18}{2(2)} = 4.5 < \lambda_{pf} = 0.38 \sqrt{\frac{E}{F_{yc}}} = 0.38 \sqrt{\frac{29,000}{50}} = 9.15$$

$$M_{nc(FLB)} = R_{pc} M_{yc} \quad (\text{AASHTO A6.3.2-1})$$

$$M_p = 2[(18 \times 2)(50)(40) + (39 \times 0.625)(50)(19.5)] \\ = 191,532 \text{ kip-in.} = 15,961 \text{ kip-ft}$$

$$M_{yc} = S_x F_{yf} = (3,413)(50) = 170,650 \text{ kip-in.} = 14,221 \text{ kip-ft}$$

$$D_{cp} = D_c = 39 \text{ in. (Section is symmetric about neutral axis)}$$

$$\lambda_{rw} = 5.7 \sqrt{\frac{E}{F_{yc}}} = 5.7 \sqrt{\frac{29,000}{50}} = 137.3$$

$$\lambda_{pw(D_{cp})} = \frac{\sqrt{\frac{29,000}{50}}}{\left(0.54 \frac{15,961}{(1.0)(14,221)} - 0.09\right)^2} = 90.43 < \lambda_{rw} \left(\frac{D_{cp}}{D_c}\right) = 137.3$$

$$\therefore \frac{2D_{cp}}{t_w} = \frac{(2)(39)}{0.625} = 124.8 > \lambda_{pw(D_{cp})} = 90.43 \quad (\text{AASHTO A6.2.1-1})$$

$$\text{and } \lambda_w = 124.8 < \lambda_{rw} = 137.3 \quad (\text{AASHTO A6.2.2-1})$$

Therefore, for a symmetric section in this example, web is non-compact and web plastification factor is calculated as follows:

$$\lambda_{pw(D_c)} = \lambda_{pw(D_{cp})} \left(\frac{D_c}{D_{cp}} \right) = 90.43 < \lambda_{rw} = 137.3 \quad (\text{AASHTO A6.2.2-6})$$

$$\begin{aligned} R_{pc} &= \left[1 - \left(1 - \frac{R_h M_y}{M_p} \right) \left(\frac{\lambda_w - \lambda_{pw(D_c)}}{\lambda_{rw} - \lambda_{pw(D_c)}} \right) \right] \frac{M_p}{M_y} \\ &= \left[1 - \left(1 - \frac{(1.0)(14,221)}{15,961} \right) \left(\frac{124.8 - 90.43}{137.3 - 90.43} \right) \right] \frac{15,961}{14,221} \quad (\text{AASHTO A6.2.2-4}) \\ &= 1.033 \end{aligned}$$

$$M_{nc(FLB)} = R_{pc} M_{yc} = (1.033)(14,221) = 14,690 \text{ kip-ft} \quad (\text{AASHTO A6.3.2-1})$$

- *Calculate Lateral Torsional Buckling Resistance*

In negative moment regions, the bottom compression flange is braced by the cross frame with a spacing of $L_b = 330$ in. at Span 2 side.

$$h = \text{depth between centerline of flanges} = (1.0 + 78 + 1.0) = 80 \text{ in.}$$

$$r_t = \frac{b_{fc}}{\sqrt{12 \left(1 + \frac{1}{3} \frac{D_c t_w}{b_{fc} t_{fc}} \right)}} = \frac{18}{\sqrt{12 \left(1 + \frac{1}{3} \frac{(39)(0.625)}{(18)(2.0)} \right)}} = 4.7 \text{ in.}$$

$$L_p = 1.0 r_t \sqrt{\frac{E}{F_{yc}}} = (1.0)(4.7) \sqrt{\frac{29,000}{50}} = 113.2 \text{ in.}$$

Ignoring rebar, from Table 9.7-21 we have $S_{xc} = S_{xt} = S_{NCb} = S_{NCt} = 3,413 \text{ in.}^3$

$$F_{yr} = \text{smaller} \left\{ \begin{array}{l} 0.7F_{yc} = (0.7)(50) = 35 \\ R_h F_{yt} S_{xt} / S_{xc} = (1.0)(50)(1.0) = 50 \\ F_{yw} = 50 \end{array} \right\} = 35 \text{ ksi} > 0.5F_{yc} = 25 \text{ ksi} \quad (\text{AASHTO A6.3.3})$$

Use $F_{yr} = 35$ ksi

$$\begin{aligned}
 J &= \frac{Dt_w^3}{3} + \frac{b_{fc}t_{fc}^3}{3} \left(1 - 0.63 \frac{t_{fc}}{b_{fc}}\right) + \frac{b_{ft}t_{ft}^3}{3} \left(1 - 0.63 \frac{t_{ft}}{b_{ft}}\right) \\
 &= \frac{(78)(0.625)^3}{3} + (2) \frac{(18)(2)^3}{3} \left(1 - 0.63 \frac{2}{18}\right) = 95.6 \text{ in.}^3
 \end{aligned}$$

(AASHTO A6.3.3-9)

$$L_r = 1.95 r_t \frac{E}{F_{yr}} \sqrt{\frac{J}{S_{xc} h}} \sqrt{1 + \sqrt{1 + 6.76 \left(\frac{F_{yr} S_{xc} h}{E J}\right)^2}}$$

(AASHTO A6.3.3-5)

$$\begin{aligned}
 L_r &= 1.95(4.7) \frac{29,000}{35} \sqrt{\frac{95.6}{(3,413)(80)}} \sqrt{1 + \sqrt{1 + 6.76 \left(\frac{35 (3,413)(80)}{29,000 (95.6)}\right)^2}} \\
 &= 449.7 \text{ in.}
 \end{aligned}$$

(AASHTO A6.3.3-5)

It is noted that a conservative L_r can be obtained by AASHTO Equation 6.10.8.2.3-5 as follows:

$$L_r = \pi r_t \sqrt{\frac{E}{F_{yr}}} = (\pi)(4.7) \sqrt{\frac{29,000}{35}} = 425.0 \text{ in.}$$

(AASHTO 6.10.8.2.3-5)

In this example, $L_r = 449.7$ in. is used.

Since $L_b = 330$ in. $>$ $L_p = 113.2$ in., C_b , an equivalent uniform moment factor for lateral torsional buckling which has a minimum value of 1.0 under the uniform moment condition, needs to be calculated. The use of the moment envelope values at both brace points will be conservative for both single and reverse curvature. In this example, the moments M_1 and M_2 at braced points are estimated from the factored moment envelope shown in Table 9.7-8. At Bent 3, $M_u = -14,008$ kip-ft and at 0.8 Point with a distance of 33 ft = 396 in. from Bent 3, $M_u = -2,751$ kip-ft. At braced point with a distance of 27.5 ft. = 330 in. from Bent 3 (Figure 9.7-8), we obtain:

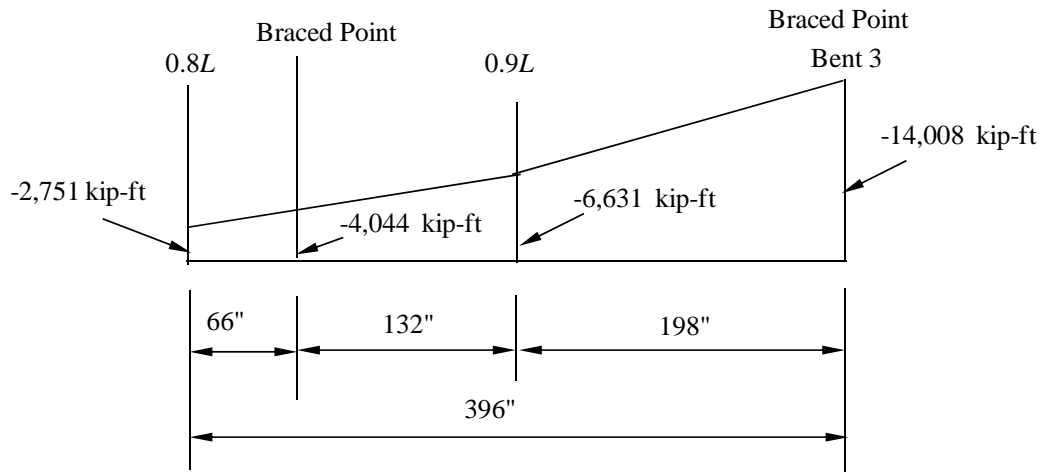

Figure 9.7-8 Factored Moment Envelope at Bent 3

$$M_1 = (-2,751) + \left(\frac{66}{198}\right)(-6,631 + 2,751) = -4,044 \text{ kip-ft}$$

$$C_b = 1.75 - 1.05 \left(\frac{M_1}{M_2}\right) + 0.3 \left(\frac{M_1}{M_2}\right)^2 = 1.75 - 1.05 \left(\frac{4,044}{14,008}\right) + 0.3 \left(\frac{4,044}{14,008}\right)^2$$

$$= 1.47 < 2.3$$

(AASHTO A6.3.3-7)

Use $C_b = 1.47$

$$\therefore L_p = 113.2 \text{ in.} < L_b = 330 \text{ in.} < L_r = 449.7 \text{ in.}$$

$$M_{nc(LTB)} = C_b \left[1 - \left(1 - \frac{F_{yr} S_{xc}}{R_h M_{yc}} \right) \left(\frac{L_b - L_p}{L_r - L_p} \right) \right] R_{pc} M_{yc}$$

$$= (1.47) \left[1 - \left(1 - \frac{(35)(3,413)}{(1.0)(14,221)(12)} \right) \left(\frac{330 - 113.2}{449.7 - 113.2} \right) \right] (1.033)(14,221)$$

$$= 17,421 \text{ kip-ft} > R_{pc} M_{yc} = 14,690 \text{ kip-ft}$$

(AASHTO A6.3.3-2)

Use $M_{nc(LTB)} = 14,690 \text{ kip-ft}$

- Determine Flexural Resistance

$$M_{nc} = \min(M_{nc(FLB)}, M_{nc(LTB)}) = \min(14,690, 14,690) = 14,690 \text{ kip-ft}$$

Calculate Flexural Resistance – Based on Tension Flange

Since the section is symmetric, $R_{pt} = R_{pc}$, $M_{yt} = M_{yc}$

$$M_{nt} = R_{pt} M_{yt} = (1.033)(14,221) = 14,690 \text{ kip-ft} \quad (\text{AASHTO A6.4-1})$$

Check Design Requirement

For both compression and tension flanges:

$$M_u = 14,009 \text{ kips-ft} < \phi_f M_{nc} = \phi_f M_{nt} = 14,690 \text{ kip-ft} \quad \text{O.K.}$$

(AASHTO A6.1.1-1 & A6.1.2-1)

9.7.11.4 Design for Shear – Strength Limit State

Select Stiffener Spacing

AASHTO C6.10.2.1.1 states that by limiting the slenderness of transversely-stiffened webs to $D/t_w \leq 150$, the maximum transverse stiffener spacing up to $3D$ is permitted. For end panels adjacent to simple supports, stiffener spacing d_o shall not exceed $1.5D$ (AASHTO 6.10.9.3.3).

Try interior stiffener spacing $d_o = 165 \text{ in.} < 3D = 3(78) = 234 \text{ in.}$ and end panel stiffener spacing $d_o = 110 \text{ in.}$ (for Span 1) and 100 in. (for Span 3) $< 1.5D = 1.5(78) = 117 \text{ in.}$

Calculate Shear Resistance

Shear resistance for a stiffened interior web is as follows:

For $d_o = 165 \text{ in.}$

$$k = 5 + \frac{5}{(165/78)^2} = 6.12$$

$$\frac{D}{t_w} = \frac{78}{0.625} = 124.8 > 1.4 \sqrt{\frac{Ek}{F_{yw}}} = (1.4) \sqrt{\frac{(29,000)6.12}{50}} = 83.41$$

$$\therefore C = \frac{1.57}{(D/t_w)^2} \left(\frac{Ek}{F_{yw}} \right) = \frac{1.57}{124.8^2} \left(\frac{29,000(6.12)}{50} \right) = 0.358$$

$$V_p = 0.58 F_{yw} D t_w = 0.58(50)(78)(0.625) = 1,413.8 \text{ kips}$$

$$V_{cr} = C V_p = (0.358)(1,413.8) = 506.1 \text{ kips}$$

$$\frac{2D t_w}{(b_{fc} t_{fc} + b_{ft} t_{ft})} = \frac{(2)(78)(0.625)}{(18 \times 2 + 18 \times 2)} = 1.35 \leq 2.5$$

$$\therefore V_n = V_p \left[C + \frac{0.87(1-C)}{\sqrt{1+(d_o/D)^2}} \right] = 1,413.8 \left[0.358 + \frac{0.87(1-0.358)}{\sqrt{1+(165/78)^2}} \right] = 843.6 \text{ kips}$$

Check Design Requirement

$$V_u = 745.1 \text{ kips} < \phi_v V_n = (1.0)(843.6) = 843.6 \text{ kips} \quad \text{O.K.}$$

It is noted that for a web end panel adjacent to the simple support, d_o for the first stiffener adjacent to the simple support shall not exceed $1.5D$ (AASHTO 6.10.9.3.3). In order to provide an anchor for the tension field in adjacent interior panels, nominal shear strength of a web end panel shall be taken as:

$$V_n = V_{cr} = CV_p \quad (\text{AASHTO 6.10.9.3.3-1})$$

Check Transverse Stiffener

The transverse stiffeners consist of plates welded or bolted to either one or both sides of the web and are required to satisfy the following requirements (AASHTO 6.10.11.1):

- *Projecting width*

$$b_t = 7.5 \text{ in.} > 2.0 + \frac{D}{30} = 2.0 + \frac{78}{30} = 4.6 \text{ in.} \quad \text{O.K.} \quad (\text{AASHTO 6.10.11.1.2-1})$$

$$16t_p = (16)(0.5) = 8 \text{ in.} > b_t = 7.5 \text{ in.} > b_f / 4 = 18 / 4 = 4.5 \text{ in.} \quad \text{O.K.}$$

(AASHTO 6.10.11.1.2-2)

- *Moment of inertia*

For the web panels adjacent to Bent 3, $V_u = 745.1 \text{ kips} > \phi_v V_{cr} = (1.0)(506.1) = 506.1 \text{ kips}$, the web tension-field resistance is required in those panels. The moment of inertia of the transverse stiffeners shall satisfy the limit specified in AASHTO 6.10.11.1.3.

$$I_{t1} = b t_w^3 J \quad (\text{AASHTO 6.10.11.1.3-3})$$

$$I_{t2} = \frac{D^4 \rho_t^{1.3}}{40} \left(\frac{F_{yw}}{E} \right)^{1.5} \quad (\text{AASHTO 6.10.11.1.3-4})$$

where I_t is the moment of inertia for the transverse stiffener taken about the edge in contact with the web for single stiffeners and about the mid-thickness of the web for stiffener pairs; b is the smaller of d_o and D ; d_o is the smaller of the adjacent web panel widths.

$$J = \frac{2.5}{(d_o/D)^2} - 2.0 \geq 0.5 \quad (\text{AASHTO 6.10.11.1.3-5})$$

ρ_t is the larger of F_{yw}/F_{crs} and 1.0

$$F_{crs} = \frac{0.31E}{(b_t/t_p)^2} \leq F_{ys} \quad (\text{AASHTO 6.10.11.1.3-6})$$

F_{ys} is specified minimum yield strength of the stiffener

$$\therefore J = \frac{2.5}{(165/78)^2} - 2.0 = -1.441 < 0.5 \quad \therefore \text{Use } J = 0.5$$

b = smaller ($d_o = 165$ in. and $D = 78$ in.) = 78 in.

$$\therefore F_{crs} = \frac{0.31(29,000)}{(7.5/0.5)^2} = 39.96 \text{ ksi} > F_{ys} = 36 \text{ ksi} \quad \text{Use } F_{crs} = 36 \text{ ksi}$$

ρ_t = larger ($F_{yw}/F_{crs} = 50/36 = 1.39$; 1.0) = 1.39

$$I_{t1} = bt_w^3 J = (78)(0.625)^3 (0.5) = 9.52 \text{ in.}^4$$

$$I_{t2} = \frac{D^4 \rho_t^{1.3} \left(\frac{F_{yw}}{E}\right)^{1.5}}{40} = \frac{(78)^4 (1.39)^{1.3} \left(\frac{50}{29000}\right)^{1.5}}{40} = 101.6 \text{ in.}^4$$

$$I_t = 2 \left(\frac{7.5^3 (0.5)}{12} + (7.5)(0.5) \left(3.75 + \frac{0.625}{2} \right)^2 \right) = 158.94 \text{ in.}^4$$

$$\therefore I_{t2} = 101.6 \text{ in.}^4 > I_{t1} = 9.52 \text{ in.}^4$$

$$I_t = 158.94 \text{ in.}^4 > I_{t1} + (I_{t2} - I_{t1}) \left(\frac{V_u - \phi_v V_{cr}}{\phi_v V_n - \phi_v V_{cr}} \right)$$

$$= 9.52 + (101.6 - 9.52) \left(\frac{745.1 - 506.1}{843.6 - 506.1} \right) = 74.73 \text{ in.}^4$$

O.K. (AASHTO 6.10.11.1.3-9)

9.7.11.5 Illustrate Calculations of Fatigue Moments and Shears

For bridge details, fatigue moment and shear ranges are calculated and summarized in Section 9.7.8. For the section at Bent 3, live load moments and shears are applied to the steel section only. Fatigue moment and shear ranges are as follows:

Fatigue I:

$$+M = \gamma(DF_m)(LL+IM)_{HL} = (1.75)(0.478)(LL+IM)_{HL} = 0.837(LL+IM)_{HL}$$

$$-M = \gamma(DF_m)(LL+IM)_{HL} = (1.75)(0.453)(LL+IM)_{HL} = 0.793(LL+IM)_{HL}$$

$$V = \gamma(DF_v)(LL+IM)_{HL} = (1.75)(0.7)(LL+IM)_{HL} = 1.225(LL+IM)_{HL}$$

$$\begin{aligned}
 +M &= (0.837)(193) = 162 \text{ kip-ft} \\
 -M &= (0.793)(-1,139) = -903 \text{ kip-ft} \\
 \gamma(\Delta M) &= 162 + 903 = 1065 \text{ kip-ft} \\
 \gamma(\Delta V) &= 1.225(74.4 + 5.3) = 97.6 \text{ kips}
 \end{aligned}$$

Fatigue II:

$$\begin{aligned}
 +M &= \gamma(DF_m)(LL+IM)_{P9} = (1.0)(0.478)(LL+IM)_{P9} = 0.478(LL+IM)_{P9} \\
 -M &= \gamma(DF_m)(LL+IM)_{P9} = (1.0)(0.453)(LL+IM)_{P9} = 0.453(LL+IM)_{P9} \\
 V &= \gamma(DF_v)(LL+IM)_{P9} = (1.0)(0.7)(LL+IM)_{P9} = 0.7(LL+IM)_{P9} \\
 +M &= (0.478)(582) = 278 \text{ kip-ft} \\
 -M &= (0.453)(-3,626) = -1,643 \text{ kip-ft} \\
 \gamma(\Delta M) &= 278 + 1,643 = 1,921 \text{ kip-ft} \\
 \gamma(\Delta V) &= 0.7(16 + 227.2) = 170.2 \text{ kips}
 \end{aligned}$$

For special fatigue requirement for the web, factored shear, V_u due to the unfactored dead loads plus the factored fatigue load of Fatigue I for infinite life is calculated as follows:

$$\begin{aligned}
 V_u &= V_{dc1} + V_{dc2} + V_{dw} + (1.75)(DF_v)(LL+IM)_{HL} \\
 &= -167.8 - 13.8 - 32.7 + (1.75)(0.7)(-74.4) = -305.4 \text{ kips}
 \end{aligned}$$

9.7.11.6 Check Typical Girder Details and Web - Fatigue Limit States

Check Typical Girder Details

From CA Table 6.6.1.2.5-2, the number of stress-range cycles per truck passage for sections near interior support, $n = 1.5$ for Fatigue I and 1.2 for Fatigue II Limit States. Nominal fatigue resistances are calculated in Table 9.7-25 as follows:

Fatigue I: $ADTT = 2,500$; $N = (365)(75)(1.5)(0.8)(2,500) = 0.8213(10)^8 > N_{TH}$

$$(\Delta F_n) = (\Delta F)_{TH} \quad \text{(AASHTO 6.6.1.2.5-1)}$$

Fatigue II: $ADTT = 20$, $N = (365)(75)(1.2)(0.8)(20) = 525,600 < N_{TH}$

$$(\Delta F_n) = \left(\frac{A}{N} \right)^{\frac{1}{3}} \quad \text{(AASHTO 6.6.1.2.5-2)}$$

Table 9.7-25 Nominal Fatigue Resistance

Detail Category	Constant -A ($\times 10^8$) (ksi ³)	Fatigue II $(\Delta F_n) = \left(\frac{A}{N}\right)^{\frac{1}{3}}$ (ksi)	Fatigue I $(\Delta F_n) = (\Delta F)_{TH}$ (ksi)
B	120.0	28.37	16.0
C	44.0	20.31	10.0
C'	44.0	20.31	12.0
E	11.0	12.79	4.5

The bending stress ranges for typical girder details Category B (Butt weld for tension flange and bolted gusset plate for lateral bracing) and Category C' (Toe of weld for transverse stiffener) are checked as follows:

Fatigue I - HL-93 Truck for infinite life:

$$\gamma(\Delta f) = \frac{\gamma(\Delta M)}{S_{NC}} = \frac{1,065(12)}{3,413} = 3.74 < 12.0 \text{ ksi O.K. for Category C'}$$

$$< 16.0 \text{ ksi O.K. for Category B}$$

Fatigue II - P-9 Truck for finite life:

$$\gamma(\Delta f) = \frac{\gamma(\Delta M)}{S_{NC}} = \frac{1,921(12)}{3,413} = 6.75 < 20.31 \text{ ksi O.K. for Category C'}$$

$$< 28.37 \text{ ksi O.K. for Category B}$$

It should be pointed out that the above stresses are calculated at the extreme fiber of the top flange for Category B and can be conservatively used for Category C'. If the calculation is made at the toe of weld for the transverse stiffeners (Category C'), the stress ranges will be smaller than the stress ranges calculated for Category B.

AASHTO 6.10.11.1.1 states that the distance between the end of the web-to-stiffener weld and the near edge of the adjacent web-to-flange weld or longitudinal stiffener-to-web weld shall not be less than $4t_w$, but not exceed the lesser of $6t_w$ and 4.0 in. We take this distance = $4t_w = 4(0.625) = 2.5$ in. and assume web-to-flange weld size of 0.375 inch. The distance between the toe of the weld for the transverse stiffeners to the neutral axis is equal to $(41 - 2 - 0.375 - 2.5) = 36.125$ in., therefore, stress ranges at the toe of the weld are as follows:

Fatigue I - HL-93 Truck for infinite life:

$$\gamma(\Delta f) = \frac{\gamma(\Delta M)C_{toe}}{I_{NC}} = \frac{1,065(12)(36.125)}{139,940} = 3.30 < 12.0 \text{ ksi O.K. for Category C'}$$

Fatigue II - P-9 Truck for finite life:

$$\gamma(\Delta f) = \frac{\gamma(\Delta M)C_{toe}}{I_{NC}} = \frac{1,921(12)(36.125)}{139,940} = 5.95 < 20.31 \text{ ksi O.K. for Category C'}$$

Check Special Fatigue Requirement for Web

This requirement is to ensure that significant elastic flexing of the web due to shear is not to occur and the member is able to sustain an infinite number of smaller loadings without fatigue cracking due to the shear.

$$V_{cr} = CV_p = (0.358)(1,413.8) = 506.1 \text{ kips} > V_u = 305.4 \text{ kips}$$

O.K. (AASHTO 6.10.5.3-1)

9.7.11.7 Design Flange-to-Web Welds

Typical flange-to-web welds shown in Figure 9.7-9 are designed for Strength Limit State. The shear flow at the flange-to-web welds is:

$$s_u = \frac{V_u Q}{I} = \frac{(745.1)(18)(2)(40)}{139,940} = 7.67 \text{ kip/in.}$$

Q is the first moment of the steel flange about the neutral axis of the steel girder section. According to AASHTO Table 6.13.3.4-1, the minimum size of fillet weld for plate thickness larger than 3/4 in. is 5/16 in., but need not exceed the thickness of the thinner part jointed. Use two fillet welds $t_w = 3/8$ in.

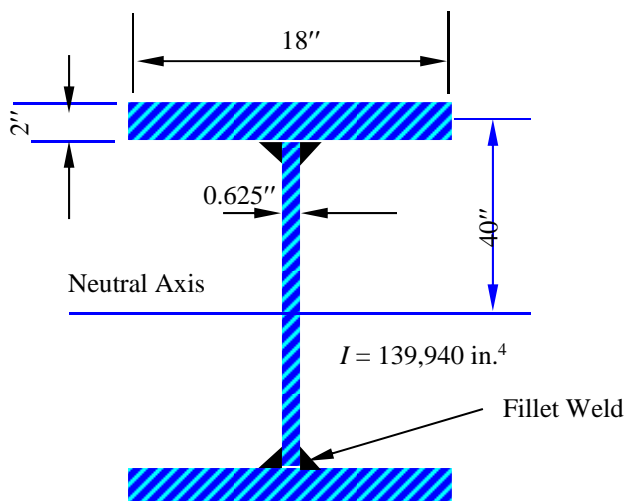

Figure 9.7-9 Flange-to-Web Welds

Shear resistance of fillet welds (AASHTO 6.13.3.2.4b) is

$$R_r = 0.6\phi_{e2}F_{exx} \quad (\text{AASHTO 6.13.3.2.4b-1})$$

F_{exx} is classification strength specified of the weld metal. Using E70XX weld metal, $F_{exx} = 70$ ksi.

$$R_r = 0.6\phi_{e2}F_{exx} = (0.6)(0.8)(70) = 33.6 \text{ ksi}$$

For two fillet welds $t_w = 3/8$ in., shear flow resistance is

$$\begin{aligned} s_r &= (2)t_w(0.707)R_r \\ &= (2)(0.375)(0.707)(33.6) = 17.82 \text{ kip/in.} > s_u = 7.67 \text{ kip/in.} \end{aligned}$$

O.K.

\therefore Use two flange-to-web welds $t_w = 3/8$ in.

Shear resistance of the base metal of the web is

$$R_r = 0.58\phi_v A_g F_y \quad (\text{AASHTO 6.13.5.3-1})$$

For web of $t_w = 0.625$ in., shear flow resistance is

$$\begin{aligned} s_r &= t_w(0.58)\phi_v F_y \\ &= (0.625)(0.58)(1.0)(50) = 18.13 \text{ kip/in.} > s_u = 7.67 \text{ kip/in.} \end{aligned} \quad \text{O.K.}$$

9.7.11.8 Check Requirements – Service Limit State

Calculate Moment at Service II

For the section at Bent 3, dead load, $DC1$, $DC2$, DW , and live load are applied to the noncomposite section. The factored moments at Service II for Bent 3 are as follows:

$$\begin{aligned} M_{DC1} &= -4,422 \text{ kip-ft} \\ M_{DC2} + M_{DW} &= -363 + (-862) = -1,225 \text{ kip-ft} \\ M_{(LL+IM)} &= (1.3)(0.834)(-3,563) = -3,863 \text{ kip-ft} \end{aligned}$$

Calculate Web Bend-buckling Resistance

$$k = 9\left(\frac{D}{D_c}\right)^2 = 9\left(\frac{78}{39}\right)^2 = 36 \quad (\text{AASHTO 6.10.1.9.1-2})$$

$$F_{crw} = \frac{0.9Ek}{\left(\frac{D}{t_w}\right)^2} = \frac{0.9(29,000)(36)}{\left(\frac{78}{0.625}\right)^2} = 60.3 \text{ ksi}$$

$$> \text{smaller} \left\{ \begin{array}{l} R_h F_{yc} = (1.0)(50) = 50 \text{ ksi} \\ F_{yw} / 0.7 = 50 / 0.7 = 71.4 \text{ ksi} \end{array} \right\} = 50 \text{ ksi}$$

(AASHTO 6.10.1.9.1-1)

Use $F_{crw} = 50 \text{ ksi}$

Check Flange Stress

In this example, $f_i = 0$ for this interior girder. The requirement becomes:

$$f_f = \frac{M_{DC1} + M_{DC2} + M_{Dw} + M_{(LL+IM)}}{S_{NC}} \leq 0.8R_h F_{yf} = (0.8)(1.0)(50) = 40.0 \text{ ksi}$$

(AASHTO 6.10.4.2.2-3)

- For both compression and tension flanges

$$f_f = \left(\frac{|-4,422| + |(-1,225)| + |(-3,863)|}{3,413} \right) (12) = 33.4 \text{ ksi} < 40.0 \text{ ksi}$$

O.K.

- For the compression flange

$$f_c = 33.4 \text{ ksi} < F_{crw} = 50.0 \text{ ksi} \quad \text{O.K.}$$

9.7.11.9 Check Requirements - Constructibility

Calculate Factored Moment and Shear - Constructibility

Factored moment and shear at the section of Bent 3 is as:

$$M_u = M_{DC1} = 1.25(-4,422) = -5,528 \text{ kip-ft}$$

$$V_u = V_{DC1} = 1.25(-167.8) = -209.8 \text{ kips}$$

Check Compression Flange

- Check Web Compactness

$$\therefore \frac{2D_c}{t_w} = \frac{78}{0.625} = 124.8 < \lambda_{rw} = 5.7 \sqrt{\frac{E}{F_{yc}}} = 5.7 \sqrt{\frac{29,000}{50}} = 137.3$$

(AASHTO 6.10.1.10.2-4)

The web is noncompact and AASHTO Equations 6.10.3.2.1-1 and 6.10.3.2.1-2 need to be satisfied.

$$R_h = 1.0; \quad R_b = 1.0$$

- Calculate Flexural Resistance

Nominal flexural resistance of the compression flange is the smaller of local buckling resistance (AASHTO 6.10.8.2.2) and the lateral torsional buckling resistance (AASHTO 6.10.8.2.3).

(1) Local buckling resistance

$$\therefore \lambda_f = \frac{b_{fc}}{2t_{fc}} = \frac{18}{2(2)} = 4.5 < \lambda_{pf} = 0.38 \sqrt{\frac{E}{F_{yc}}} = 0.38 \sqrt{\frac{29,000}{50}} = 9.15$$

$$F_{nc(FLB)} = R_b R_h F_{yc} = (1.0)(1.0)(50) = 50.0 \text{ ksi} \quad (\text{AASHTO 6.10.8.2.2-1})$$

(2) Lateral torsional buckling resistance

From Section 9.7.11.3, we have

$$r_t = \frac{b_{fc}}{\sqrt{12 \left(1 + \frac{1}{3} \frac{D_c t_w}{b_{fc} t_{fc}} \right)}} = 4.7 \text{ in.} \quad (\text{AASHTO 6.10.8.2.3-9})$$

$$L_p = 1.0 r_t \sqrt{\frac{E}{F_{yc}}} = 113.2 \text{ in.} \quad (\text{AASHTO 6.10.8.2.3-4})$$

$$F_{yr} = 35 \text{ ksi}$$

$$L_r = \pi r_t \sqrt{\frac{E}{F_{yr}}} = 425.0 \text{ in.} \quad (\text{AASHTO 6.10.8.2.3-5})$$

$$\therefore L_p = 113.2 \text{ in.} < L_b = 330 \text{ in.} < L_r = 425.0 \text{ in.}$$

$$F_{nc(LTB)} = C_b \left[1 - \left(1 - \frac{F_{yr}}{R_h F_{yc}} \right) \frac{L_b - L_p}{L_r - L_p} \right] R_b R_h F_{yc} \leq R_b R_h F_{yc} \quad (\text{AASHTO 6.10.8.2.3-2})$$

$$\begin{aligned} F_{nc(LTB)} &= (1.0) \left[1 - \left(1 - \frac{35}{(1.0)(50)} \right) \frac{330 - 113.2}{425 - 113.2} \right] (1.0)(1.0)(50) \\ &= 39.6 \text{ ksi} \leq R_b R_h F_{yc} = 50 \text{ ksi} \end{aligned}$$

Use $F_{nc(LTB)} = 39.6 \text{ ksi}$

It should be pointed out that the C_b factor is taken as 1.0 conservatively in the constructibility check.

(3) Nominal flexural resistance

$$F_{nc} = \min \left(F_{nc(FLB)}, F_{nc(LTB)} \right) = \min (50.0, 39.6) = 39.6 \text{ ksi}$$

$$f_{bu} = \frac{M_u}{S_{NCb}} = \frac{5,528(12)}{3,413} = 19.4 \text{ ksi} < \phi_f F_{nc} = 39.6 \text{ ksi} \quad \text{O.K.}$$

(AASHTO 6.10.3.2.1-2)

• Calculate Web Bend-Buckling Resistance

$$k = 9 \left(\frac{D}{D_c} \right)^2 = 9 \left(\frac{78}{39} \right)^2 = 36 \quad \text{(AASHTO 6.10.1.9.1-2)}$$

$$F_{crw} = \frac{0.9 E k}{\left(\frac{D}{t_w} \right)^2} = \frac{0.9(29,000)(36)}{\left(\frac{78}{0.625} \right)^2} = 60.3 \text{ ksi} \quad \text{(AASHTO 6.10.1.9.1-1)}$$

$$> \text{smaller} \begin{cases} R_h F_{yc} = (1.0)(50) = 50 \text{ ksi} \\ F_{yw} / 0.7 = 50 / 0.7 = 71.4 \text{ ksi} \end{cases}$$

Use $F_{crw} = 50 \text{ ksi}$

$$f_{bu} = 19.4 \text{ ksi} < \phi_f F_{crw} = 50 \text{ ksi} \quad \text{O.K.} \quad \text{(AASHTO 6.10.3.2.1-3)}$$

Check Tension Flange

$$f_{bu} = \frac{M_u}{S_{NCt}} = \frac{5,528(12)}{3,413} = 19.4 \text{ ksi} < \phi_f R_h F_{yt} = 50 \text{ ksi}$$

O.K. (AASHTO

6.10.3.2.2-1)

Check for Shear

From Section 9.7.11.4, we obtain:

$$C = 0.358, \quad V_p = 0.58 F_{yw} D_t = 1,413.8 \text{ kips}$$

$$V_{cr} = C V_p = (0.358)(1,413.8) = 506.1 \text{ kips}$$

$$V_u = 209.8 \text{ kips} < \phi_v V_{cr} = (1.0)(506.1) = 506.1 \text{ kips} \quad \text{O.K.}$$

(AASHTO 6.10.3.3-1)

9.7.12 Design Shear Connectors for Span 2

The shear connectors are provided in the positive moment regions and usually designed for fatigue and checked for strength.

9.7.12.1 Design for Fatigue

The range of horizontal shear flow, V_{sr} , is as follows:

$$V_{sr} = \frac{V_f Q}{I_{ST}}$$

where V_f is the factored fatigue vertical shear force range as calculated in Tables 9.7-11 and 9.7-12, I_{ST} is the moment of inertia of the transformed short-term composite section, and Q is the first moment of transformed short-term area of the concrete deck about the neutral axis of the short-term composite section.

From Table 9.7-17, $I_{ST} = 275,267 \text{ in.}^4$

$$Q = (A_c / n)(y_c - y_{STb}) = (164.25)(88.44 - 68.51) = 3,274 \text{ in.}^3$$

$$V_{sr} = \frac{V_f Q}{I_{ST}} = \frac{3,274 V_f}{275,267} = 0.012 V_f$$

Try $d = 7/8$ inch diameter stud, 3 per row, the fatigue shear resistance of an individual stud shear connector, Z_r is as follows:

Fatigue I: $ADTT = 2500$

$$N = (365)(75)(1.0)(0.8)(2500) = 0.5475(10)^8 > 5.966(10)^6$$

$$Z_r = 5.5d^2 = 5.5(0.875)^2 = 4.21 \text{ kips} \quad (\text{AASHTO 6.10.10.2-1})$$

Fatigue II: $ADTT = 20$

$$N = (365)(75)(1.0)(0.8)(20) = 438,000 < 5.966(10)^6$$

$$\alpha = 34.5 - 4.28 \log N = 34.5 - 4.28 \log [438,000] = 10.35 \quad (\text{AASHTO 6.10.10.2-3})$$

$$Z_r = \alpha d^2 = 10.35(0.875)^2 = 7.93 \text{ kips} \quad (\text{AASHTO 6.10.10.2-2})$$

For 3 - $d = 7/8$ inch diameter studs, the required pitch of shear connectors, p is obtained as:

$$p = \frac{nZ_r}{V_{sr}} = \frac{3Z_r}{V_{sr}} \quad (\text{AASHTO 6.10.10.1.2-1})$$

For the positive moment region (0.2L to 0.8L) of Span 2, the detailed calculation is shown in Table 9.7-26.

Table 9.7-26 Pitch of Shear Connectors for Span 2

x/L	Fatigue I - HL-93 Truck for infinite life			Fatigue II - P-9 Truck for finite life		
	V_f (kip)	$V_{sr} = 0.012 V_f$ (kip/in.)	p (in.)	V_f (kip)	$V_{sr} = 0.012 V_f$ (kip/in.)	p (in.)
0.2	81.6	0.98	12.9	137.1	1.65	14.4
0.3	77.7	0.93	13.6	120.3	1.44	16.5
0.4	75.9	0.91	13.9	113.1	1.36	17.5
0.5	73.8	0.89	14.1	108.0	1.30	18.3
0.6	75.7	0.91	13.9	112.3	1.35	17.6
0.7	77.2	0.93	13.6	119.0	1.43	16.6
0.8	80.7	0.97	13.0	131.5	1.58	15.1

Select 3-7/8" diameter shear studs with $F_u = 60$ ksi (AASHTO 6.4.4) at spacing of 12" for the positive moment regions, and 24" for the negative moment regions as shown in Figure 9.7-10. Total number of shear studs from 0.2L to 0.8L Points in Span 2, $n = (3)(99+1) = 300$ are provided.

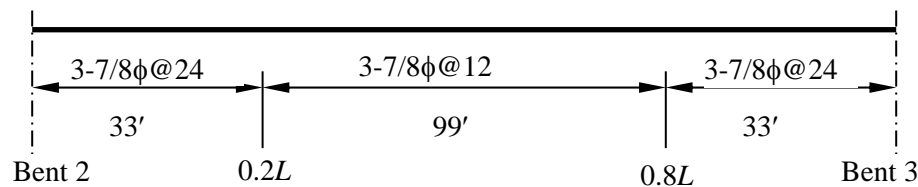

Figure 9.7-10 Pitch of Shear Studs

AASHTO Table 6.6.1.2.3-1 requires that the base metal shall be checked for Category C when the shear studs are attached by fillet welds to the girders. From Section 9.7.10.5, it is seen that this requirement is satisfied.

9.7.12.2 Check for Strength

In this example of straight bridge, the number of shear connectors between the point of maximum positive moment and each adjacent point of zero moment shall satisfy the following requirement:

$$n = \frac{P}{Q_r} \quad (\text{AASHTO 6.10.10.4.1-2})$$

$$P = \text{smaller} \left\{ \begin{array}{l} 0.85 f'_c b t_s = (0.85)(3.6)(144)(9.125) = 4,021 \\ A_s F_y = (98.25)(50) = 4,913 \end{array} \right\} = 4,021 \text{ kips}$$

(AASHTO 6.10.10.4.2-2) and (AASHTO 6.10.10.4.2-3)

The factored shear resistance of a single $d = 7/8$ in. shear stud connector is as:

$$E_c = w^{3/2} (33) \sqrt{f'_c} = (150)^{3/2} (33) \sqrt{3,600} = 3.64 \times 10^6 \text{ psi} = 3,640 \text{ ksi}$$

(AASHTO 5.4.2.4-1)

$$Q_n = 0.5 A_{sc} \sqrt{f'_c E_c} = 0.5 \frac{(0.875)^2 \pi}{4} \sqrt{3.6(3,640)}$$

$$= 34.4 \text{ kips} < A_{sc} F_u = \frac{\pi}{4} (0.875)^2 (60) = 36.1 \text{ kips}$$

(AASHTO 6.10.10.4.3-1)

Use $Q_n = 34.4$ kips

$$n = \frac{300}{2} = 150 > \frac{P}{\phi_{sc} Q_n} = \frac{4,021}{0.85 (34.4)} = 137.5 \quad \text{O.K.}$$

9.7.12.3 Determine Shear Connectors at Points of Contraflexure

AASHTO 6.10.10.3 requires that for members that are noncomposite for negative moment regions in the final condition, additional connectors, n_{ac} shall be placed within a distance equal to one-third of the effective concrete deck width on each side of the point of permanent load contraflexure.

$$n_{ac} = \frac{A_s f_{sr}}{Z_r} \quad (\text{AASHTO 6.10.10.3-1})$$

where f_{sr} is fatigue stress range in the slab reinforcement over the interior support under the Fatigue I load combination for infinite fatigue life.

As calculated in Section 9.7.11.5, factored Fatigue I moment range at Bent 3, $\gamma(\Delta M) = 1,065$ kips-ft. Using the elastic section property of the steel section and deck slab reinforcement calculated in Table 9.7-22, we obtain:

$$f_{sr} = \frac{\gamma(\Delta M)}{S_{NSrb}} = \frac{1,065(12)}{3,880} = 3.3 \text{ ksi}$$

It is noted that f_{sr} can be conservatively taken as the fatigue stress range in the top flange as calculated in Section 9.7.11.6. In the past AASHTO Standard Specifications, f_{sr} was assumed as 10 ksi.

$$n_{ac} = \frac{A_s f_{sr}}{Z_r} = \frac{13.14(3.3)}{4.21} = 10.3 \text{ studs}; \quad \text{Use 12 studs}$$

9.7.13 Design Bearing Stiffeners at Bent 3

The bearing stiffeners consist of one or more plates welded to each side of the web and extend the full height of the web. The purpose of bearing stiffeners is to transmit the full bearing forces from factored loads. The bearing stiffeners shall be designed for axial resistance of a concentrically loaded column (AASHTO 6.10.11.2.4) and for bearing resistance (AASHTO 6.10.11.2.3).

9.7.13.1 Illustrate Calculations of Factored Support Forces at Bent 3

Factored support forces for four supports at the strength limit states are summarized in Table 9.7-10. The calculations of factored support forces at Bent 3 are illustrated as follows:

Dead Load

$$R_{DC1} = 1.25(328.2) = 410.3 \text{ kips}$$

$$R_{DC2} = 1.25(27) = 33.8 \text{ kips}$$

$$R_{DW} = 1.5(64) = 96.0 \text{ kips}$$

Live Load

$$R_{(LL+IM)HL-93} = 1.75(1.082)(249.2) = 471.9 \text{ kips}$$

$$R_{(LL+IM)P15} = 1.35(1.082)(447) = 652.9 \text{ kips}$$

Controlling Support Force

$$R_u = 410.3 + 33.8 + 96.0 + 652.9 = 1,193 \text{ kips}$$

9.7.13.2 Select Stiffeners

For a short column, assume $P_r = 0.85F_{ys}A_s = 0.85(36)A_s = 30.6A_s$ and we obtain the initial effective column area as:

$$A_s = \frac{R_u}{30.6} = \frac{1,193}{30.6} = 38.99 \text{ in.}^2$$

Try two stiffeners, 1.875" × 8" PL as shown in Figure 9.7-11.

9.7.13.3 Check Projecting Width

$$b_t = 8 \text{ in.} < 0.48t_p \sqrt{\frac{E}{F_{ys}}} = (0.48)(1.875) \sqrt{\frac{29,000}{36}} = 25.54 \text{ in.} \quad \text{O.K.}$$

(AASHTO 6.10.11.2.2-1)

9.7.13.4 Check Bearing Resistance

Factored bearing resistance is as:

$$(R_{sb})_r = \phi_b (R_{sb})_n = (1.0)(1.4)A_{pn} F_{ys} \quad (\text{AASHTO 6.10.11.2.3-1 and 6.10.11.2.3-2})$$

Assuming 1.5 in. cope on bearing stiffeners, the bearing area is:

$$A_{pn} = (2)(8 - 1.5)(1.875) = 24.375 \text{ in.}^2$$

$$(R_{sb})_r = (1.0)(1.4)(24.375)(36) = 1,228.5 \text{ kips} > R_u = 1,193 \text{ kips} \quad \text{O.K.}$$

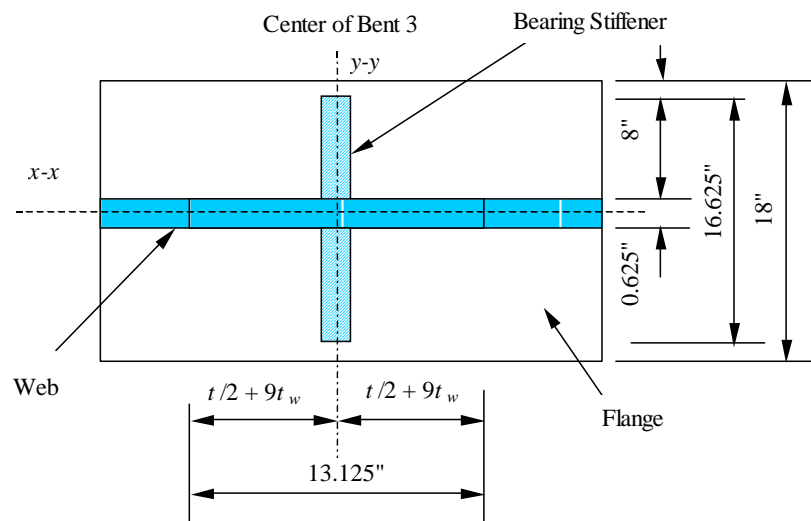

Figure 9.7.11 Bearing Stiffeners

9.7.13.5 Check Axial Resistance

According to AASHTO 6.10.11.2.4b, for stiffeners welded to the web, the effective column section consists of stiffener plates and a centrally loaded strip of the web extending not more than $9t_w$ on each side of the stiffeners.

$$\text{Stiffener area: } A_{st} = (2)(8)(1.875) = 30 \text{ in.}^2$$

$$\begin{aligned} \text{Web area: } A_{web} &= [18 t_w + t_p] t_w = [18(0.625) + 1.875](0.625) \\ &= (13.125)(0.625) = 8.20 \text{ in.}^2 \end{aligned}$$

Total effective column area: $A_y = 30 + 8.20 = 38.2 \text{ in.}^2$

$$I_{x-x} = \frac{(18)(0.625)(0.625)^3 + (1.875)[(2)(8) + 0.625]^3}{12} = 718 \text{ in.}^4$$

$$r_s = \sqrt{\frac{I_{x-x}}{A_y}} = \sqrt{\frac{718}{38.2}} = 4.34 \text{ in.}$$

Use effective length factor $K = 0.75$ for the weld end connection (AASHTO 6.10.11.2.4a), unbraced length for the bearing stiffeners $l = D = 78 \text{ in.}$

$$\frac{Kl}{r_s} = \frac{0.75(78)}{4.34} = 13.5 < 120 \quad \text{O.K.} \quad (\text{AASHTO 6.9.3})$$

Axial resistance is calculated in accordance with AASHTO 6.9.4.1 as follows:

$$P_e = \frac{\pi^2 E}{\left(\frac{Kl}{r_s}\right)^2} A_s = \frac{\pi^2 (29,000)}{(13.5)^2} (38.2) = 59,992.0 \text{ kips} \quad (\text{AASHTO 6.9.4.1.2-1})$$

$P_o = QF_{ys} A_s = (1.0)(36)(38.2) = 1,375.2 \text{ kips}$ (Q is taken equal to 1.0 for bearing stiffeners in accordance with AASHTO 6.9.4.1.1)

$$\therefore \frac{P_e}{P_o} = \frac{59,992.0}{1,375.2} = 43.62 > 0.44$$

$$\therefore P_n = \left[0.658 \left(\frac{P_o}{P_e} \right) \right] P_o = \left[0.658 \left(\frac{1,375.2}{59,992.0} \right) \right] (1,375.2) = 1,362.1 \text{ kips}$$

(AASHTO 6.9.4.1.1-1)

$$P_r = \phi_c P_n = (0.9)(1,362.1) = 1,225.9 \text{ kips} > R_u = 1,193 \text{ kips} \quad \text{O.K.}$$

\therefore Use two 1.875" \times 8" PL bearing stiffeners

9.7.13.6 Design Bearing Stiffener-to-Web Welds

Fillet welds are usually used for bearing stiffener-to-web connections. According to AASHTO Table 6.13.3.4-1, the minimum size of fillet weld for thicker plate thickness joined larger than 3/4 in. is 5/16 in., but need not exceed the thickness of the thinner part joined. Try two fillet welds $t_w = 5/16 \text{ in.}$ on each stiffener.

Shear resistance of fillet welds (AASHTO 6.13.3.2.4b) is

$$R_r = 0.6 \phi_{e2} F_{exx} \quad (\text{AASHTO 6.13.3.2.4b-1})$$

Using E70XX weld metal, $F_{exx} = 70 \text{ ksi.}$

$$R_r = 0.6\phi_{e2}F_{exx} = (0.6)(0.8)(70) = 33.6 \text{ ksi}$$

Total length of welds, allowing 2.5 inches for clips at both the top and bottom of the stiffener, is:

$$L = 78 - 2(2.5) = 73 \text{ in.}$$

Total shear resistance of welds connecting the bearing stiffeners to the web is:

$$\begin{aligned} V_r &= (4)(0.707)t_w L R_r \\ &= (4)(0.707)(0.3125)(73)(33.6) = 2,168 \text{ kips} > V_u = 1,193 \text{ kips} \quad \text{O.K.} \\ \therefore \text{ Use two fillet welds } t_w &= 3/8 \text{ in. on each stiffener} \end{aligned}$$

9.7.14 Design Intermediate Cross Frames

An intermediate cross frame consisting of single angles is selected as shown in Figure 9.7-12.

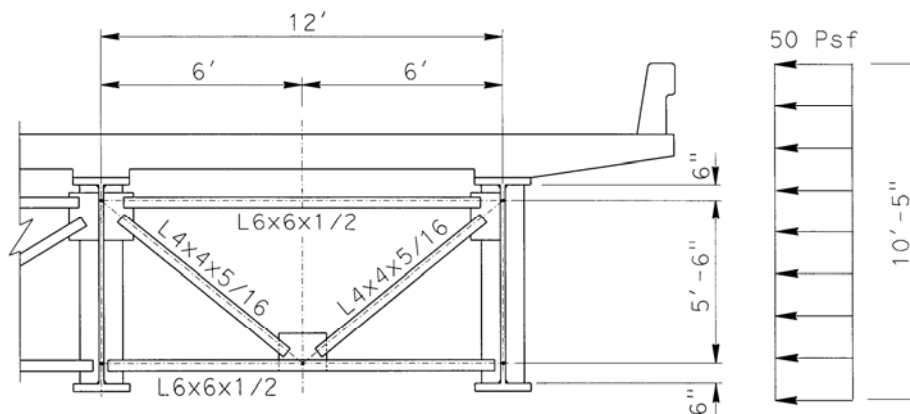

Figure 9.7.12 A Typical Intermediate Cross Frame

9.7.14.1 Calculate Wind Load

Design wind pressure is determined as:

$$P_D = P_B \left(\frac{V_{DZ}}{V_B} \right)^2 = P_B \frac{V_{DZ}^2}{10,000} \quad (\text{AASHTO 3.8.1.2.1-1})$$

$$P_B = \text{base wind pressure} = 0.05 \text{ ksf (for beams)} \quad (\text{AASHTO Table 3.8.1.2.1-1})$$

$$V_{DZ} = 2.5V_o \left(\frac{V_{30}}{V_B} \right) \ln \left(\frac{Z}{Z_o} \right) \quad (\text{AASHTO 3.8.1.1-1})$$

Assume the steel girder is 35 ft. above the low ground, and the bridge is located in the suburban area, $Z = 35$ ft., $Z_o = 3.28$ ft., $V_o = 10.9$ mph, $V_{30} = V_B = 100$ mph (AASHTO Table 3.8.1.1-1).

$$V_{DZ} = 2.5V_o \left(\frac{V_{30}}{V_B} \right) \ln \left(\frac{Z}{Z_o} \right) = (2.5)(10.9) \left(\frac{100}{100} \right) \ln \left(\frac{35}{3.28} \right) = 64.5 \text{ mph}$$

$$P_D = P_B \frac{V_{DZ}^2}{10,000} = (0.05) \frac{64.5^2}{10,000} = 0.02 \text{ ksf}$$

In this example, the midspan girder depth $d = 80.75 \text{ in.} = 6.73 \text{ ft}$, depth of deck and barrier $= 12.25 + 32 = 44.25 \text{ in.} = 3.69 \text{ ft}$.

Wind load acting on the girder span is as:

$$WS_{girder} = P_D(3.69 + 6.73) = (0.02)(10.42) = 0.21 \text{ kip/ft} < 0.3 \text{ kip/ft}$$

Use $WS_{girder} = 0.3 \text{ kip/ft}$ (AASHTO 3.8.1.2.1)

Wind load acting on the bottom flange is as:

$$WS_{bf} = \frac{WS_{girder}(d/2)}{(3.69 + 6.73)} = \frac{(0.3)(6.73/2)}{10.42} = 0.097 \text{ kip/ft}$$

Wind force acting on top flange (directly transmitted to the concrete deck)

$$W_{tf} = 0.3 - 0.097 = 0.203 \text{ kip/ft}$$

9.7.14.2 Check Flexural Resistance of Bottom Flange

For cross frame spacing, $L_b = 27.5 \text{ ft}$, wind induced moment applied on the bottom flange of the exterior girder is estimated as:

$$M_{WS} = \frac{WS_{bf} L_b^2}{10} = \frac{(0.097)(27.5)^2}{10} = 7.34 \text{ kip-ft} \quad (\text{AASHTO C4.6.2.7.1-2})$$

For the smaller bottom flange, wind induced lateral stress is:

$$f_{l-WS} = \frac{M_{WS}}{t_f b_f^2 / 6} = \frac{(7.34)(12)}{(1.75)(18)^2 / 6} = 0.93 \text{ ksi}$$

From CA Table 3.4.1, the load combinations Strength III and V are:

For Strength III: $1.25DC + 1.5DW + 1.4WS$

For Strength V: $1.25DC + 1.5DW + 1.35DF(LL+IM)_{HL-93} + 0.4WS$

It is obvious that Strength V controls design. In this example, the section at 0.5 Point of Span 2 is checked. From Table 9.7-8, Factored moments about major axis of the cross section are as:

$$M_{DC1} = 3,269 \text{ kip-ft}; \quad M_{DC2} = 269 \text{ kip-ft}$$

$$M_{DW} = 765 \text{ kip-ft}; \quad M_{(LL+IM)_{HL-93}} = 1.35(0.805)(3,455) = 3,755 \text{ kip-ft}$$

$$M_u = 3269 + 269 + 765 + 3,755 = 8,058 \text{ kip-ft}$$

The factored lateral bending stress in the bottom flange due to wind load is:

$$f_l = (0.4)f_{l-WS} = (0.4)(0.93) = 0.37 \text{ ksi} < 0.6F_{yf} = 30 \text{ ksi} \quad \text{O.K.}$$

(AASHTO 6.10.1.6-1)

At the strength limit state, the composite compact section in positive moment regions shall satisfy the requirement as follows:

$$M_u + \frac{1}{3}f_l S_{xt} \leq \phi_f M_n \quad (\text{AASHTO 6.10.7.1.1-1})$$

where $S_{xt} = M_{yt}/F_{yt}$

From Section 9.7.10.3, $M_{yt} = 15,287 \text{ kip-ft}$ and $M_n = 19,873 \text{ kip-ft}$

$$S_{xt} = \frac{M_{yt}}{F_{yt}} = \frac{15,287(12)}{50} = 3,669 \text{ in.}^3$$

$$\begin{aligned} M_u + \frac{1}{3}f_l S_{xt} &= 8,058 + \frac{1}{3}(0.37)\frac{3,669}{12} = 8,096 \text{ kip-ft} \\ &\leq \phi_f M_n = 19,873 \text{ kip-ft} \end{aligned} \quad \text{O.K.}$$

9.7.14.3 Calculate Forces Acting on the Cross Frame

In order to find forces acting in the cross frame members, a cross frame is treated like a truss with tension diagonals only and solved using statics. The wind force in the top strut is assumed zero because the diagonals will transfer the wind load directly into the deck slab. The horizontal wind forces applied to the brace points are assumed to be carried fully by the bottom strut in the exterior bays. Therefore, the bottom strut in all bays will be conservatively designed for this force.

At Strength Limit III, factored wind force acting on the bottom strut is:

$$P_u = 1.4WS_{bf}L_b = (1.4)(0.097)(27.5) = 3.73 \text{ kips}$$

Factored force acting on diagonals is:

$$P_u = \frac{3.73}{\cos\phi} = \frac{3.73}{6/\sqrt{5.5^2 + 6^2}} = 5.06 \text{ kips}$$

9.7.14.4 Design Bottom Strut

Select Section

Try L 6×6×1/2 as shown in Figure 9.7-13.

$$\begin{array}{lll}
 A_g = 5.77 \text{ in.}^2; & I_x = I_y = 19.9 \text{ in.}^4; & r_x = r_y = 1.86 \text{ in.} \\
 x = y = 1.67 \text{ in.}; & r_z = 1.18 \text{ in.}; & \text{Tan } \alpha = 1.0
 \end{array}$$

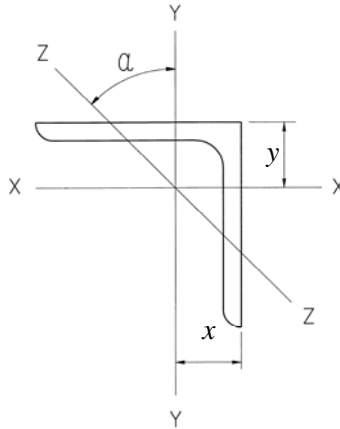

Figure 9.7-13 Single Angle for Bottom Strut

Check Limiting Effective Slenderness Ratio

AASHTO 6.9.3 requires that the effective slenderness ratio, KL/r shall not exceed 140 for compression bracing members. For buckling about minor principal axis (Z-Z), using unbraced length $L_z = 6 \text{ ft} = 72 \text{ in.}$ and effective length factor $K = 1.0$ for single angles regardless of end conditions (AASHTO 4.6.2.5), the effective slenderness ratio is:

$$\frac{KL_z}{r_z} = \frac{(1.0)(72)}{1.18} = 61 < 140 \quad \text{O.K.}$$

For out-plane buckling about vertical geometric axis (Y-Y), using unbraced length $L_y = 12 \text{ ft} = 144 \text{ in.}$ and effective length factor $K = 1.0$, the effective slenderness ratio is:

$$\frac{KL_y}{r_y} = \frac{(1.0)(144)}{1.86} = 77.4 < 140 \quad \text{O.K.}$$

Check Member Strength

Since a single angle member is connected through one leg only, the member is subjected to combined flexural moments about principal axes due to eccentrically

applied axial load and axial compression. AASHTO Article 6.9.4.4 states that single angles subjected to combined axial compression and flexure may be designed as axially loaded compression members in accordance with AASHTO Articles 6.9.2.1, 6.9.4.1.1, and 6.9.4.1.2, as appropriate, using one of the effective slenderness ratios specified by AASHTO Article 6.9.4.4, provided that: (1) end connections are to a single leg of the angle, and are welded or use minimum two-bolt connections; (2) angles are loaded at the ends in compression through the same one leg; and (3) there are no intermediate transverse loads. It is obvious that the bottom strut meets those three conditions and can be designed in accordance with AASHTO Article 6.9.4.4.

- Determine Effective Slenderness Ratio

For equal-leg angles that are individual members, $\frac{L}{r_x} = \frac{(144)}{1.86} = 77 < 80$

$$\left(\frac{KL}{r}\right)_{eff} = 72 + 0.75\frac{L}{r_x} = 72 + (0.75)\frac{144}{1.86} = 130 \quad (\text{AASHTO 6.9.4.4-1})$$

- Determine Slender Element Reduction Factor, Q

$$\therefore \frac{b}{t} = \frac{6}{0.5} = 12 < k\sqrt{\frac{E}{F_y}} = 0.45\sqrt{\frac{29,000}{36}} = 12.8 \quad (\text{AASHTO 6.9.4.2.1-1})$$

$$\therefore Q = 1.0$$

- Determine Nominal Axial Compression Strength

Axial resistance is calculated in accordance with AASHTO 6.9.4.1 as follows:

$$P_e = \frac{\pi^2 E}{\left(\frac{KL}{r_s}\right)_{eff}^2} A_g = \frac{\pi^2 (29,000)}{(130)^2} (5.77) = 97.72 \text{ kips} \quad (\text{AASHTO 6.9.4.1.2-1})$$

$$P_o = QF_{ys} A_s = (1.0)(36)(5.77) = 207.72 \text{ kips}$$

$$\therefore \frac{P_e}{P_o} = \frac{97.72}{207.72} = 0.47 > 0.44$$

$$\therefore P_n = \left[0.658\left(\frac{P_o}{P_e}\right)\right] P_o = \left[0.658\left(\frac{207.72}{97.72}\right)\right] (207.72) = 85.33 \text{ kips}$$

(AASHTO 6.9.4.1-1)

- Check Compressive Strength

$$P_u = 3.73 \text{ kips} < \phi_c P_n = (0.9)(85.33) = 76.70 \text{ kips} \quad \text{O.K.}$$

9.7.14.5 Design Diagonal

Select Section

$$\text{Try L } 4 \times 4 \times 5/16, \quad A_g = 2.4 \text{ in.}^2 \quad r_{\min} = 0.781 \text{ in.}$$

$$L = \sqrt{5.5^2 + 6^2} = 8.14 \text{ ft.} = 98 \text{ in.}$$

Check Limiting Effective Slenderness Ratio

$$\frac{KL}{r_{\min}} = \frac{(1.0)(98)}{0.791} = 123.0 < 140 \quad \text{OK} \quad (\text{AASHTO 6.9.3})$$

Check Member Strength

A separate calculation similar to the above bottom strut design shows that angle L 4×4×5/16 meets specification requirements.

9.7.14.6 Design Top Strut

Since the force in the top strut is assumed zero, we select an angle L 6×6×1/2 to provide lateral stability to the top flange during construction and to design for 2 percent of the flange yield strength. Design calculation is similar with the above for the bottom strut and is not illustrated here.

9.7.14.7 Design Connection of Bottom Strut

Determine Design Load

For end connections of diaphragms and cross frames in straight girder bridges, AASHTO 6.13.1 requires that it shall be designed for the calculated member forces. In this example, the connection of the bottom strut is designed for the calculated member load, $P_u = 3.73$ kips.

Determine Number of Bolts Required

- Select Bolts

Try A325 high-strength 3/4 in. diameter bolt with threads excluded from the shear plane, with bolt spacing of 3 in. and edge distance of 1.75 in. For 3/4 in. diameter bolts, minimum spacing of bolts is $3d = 2.25$ in. (AASHTO 6.13.2.6.1) and minimum edge distance from center of standard hole to edge of connected part is 1.25 in. for sheared edges (AASHTO Table 6.13.2.6.6-1).

- Determine Nominal Resistance per Bolt

Calculate nominal shear resistance in single shear

$$R_n = 0.48A_b F_{ub} N_s \quad (\text{AASHTO 6.13.2.7-1})$$

$$A_b = \left(\frac{0.75}{2}\right)^2 \pi = 0.442 \text{ in.}^2$$

$$F_{ub} = 120 \text{ ksi} \quad (\text{AASHTO 6.4.3})$$

$$N_s = 1 \text{ (for single shear)}$$

$$R_n = 0.48A_b F_{ub} N_s = (0.48)(0.442)(120)(1) = 25.5 \text{ kips} \quad (\text{AASHTO 6.13.2.7-1})$$

Calculate the design bearing strength for each bolt on stiffener material

Since the clear edge distance, $L_c = 1.75 - (0.75 + 0.0625)/2 = 1.344 \text{ in.}$ is less than $2d = 1.5 \text{ in.}$ and stiffener material is A709 Grade 36, $F_u = 58 \text{ ksi.}$

$$R_n = 1.2L_c t F_u = 1.2(1.344)(0.5)(58) = 46.8 \text{ kips} \quad (\text{AASHTO 6.13.2.9-2})$$

Determine design strength per bolt

It is obvious that shear controls and nominal shear resistance per bolt is 25.5 kips.

- Determine Number of Bolts Required

The number of bolts required is:

$$N = \frac{P_u}{\phi_s R_v} = \frac{3.73}{(0.8)(25.5)} = 0.2 \text{ bolts}$$

Use 2 bolts as shown in Figure 9.7-14.

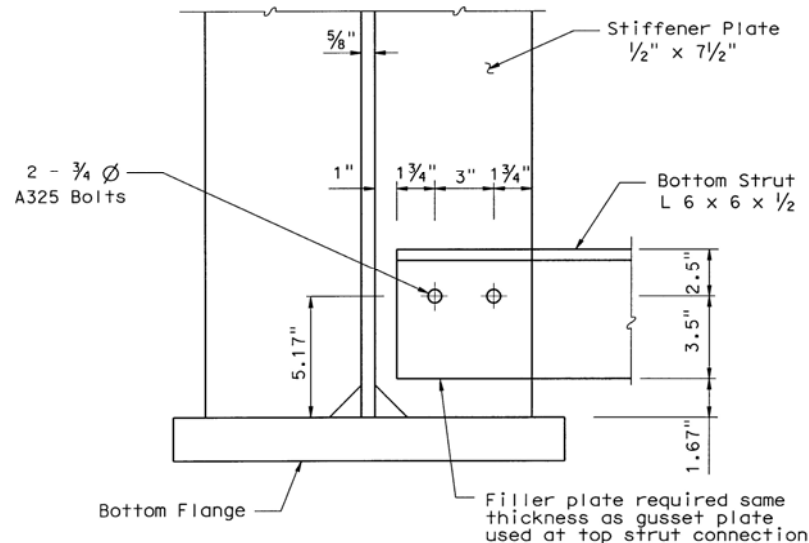

Figure 9.7-14 Bottom Strut Connection

9.7.15 Design Bolted Field Splices

9.7.15.1 General Design Requirements

For flexural members, splices shall preferably be made at or near points of dead load contraflexure in continuous spans and at points of the section change. AASHTO 6.13.6.1.4a states that bolted splices for flexural members shall be designed using slip-critical connections as specified by AASHTO 6.13.2.1.1. The general design requirements are:

- Factored resistance of splices shall not be less than 100 percent of the smaller factored resistances of the section spliced at the strength limit state (CA 6.13.1).
- Slip shall be prevented at the service limit state II (AASHTO 6.13.2.1.1) and during erection of the steel and during the casting or placing of the deck (AASHTO 6.13.6.1.4a).
- Base metal at the gross section shall be checked for Category B at the fatigue limit state (AASHTO Table 6.6.1.2.3-1).

As shown in Figure 9.7-4, bolted field girder splices for Span 2 are located approximately at 0.3 and 0.7 Points. In the following, the design of a bolted splice (Figure 9.7-15) as a slip-critical connection at 0.7 Point will be illustrated. Oversized or slotted holes shall not be used (AASHTO 6.13.6.1.4a). The hole diameter used in calculation shall be 1/16 in. larger than the nominal diameter as shown in AASHTO Table 6.13.2.4.2-1.

9.7.15.2 Design Bottom Flange Splices

Try one outer splice plate 1 in. × 18 in., two inner plates 1-1/8 in. × 8 in. and one fill plate 1/4 in. × 18 in. as shown in Figure 9.7-16.

Try A325 high-strength $d = 7/8$ in. bolt threads excluded with bolt spacing of 3 in. and edge distance of 2 in. For 7/8 in. diameter bolts, the minimum spacing of bolts is $3d = 2.625$ in. (AASHTO 6.13.2.6.1) and minimum edge distance from center of standard hole to edge of connected part is 1.5 in. for sheared edges (AASHTO Table 6.13.2.6.6-1). The standard hole size for a $d = 7/8$ in. bolt is 0.9375 in. (AASHTO Table 13.2.4.2-1).

Determine Number of Bolts Required – Strength Limit States

- Determine Design Forces

$$F_{cf} = \alpha \phi_f F_{yf} \quad (\text{CA 6.13.6.1.4c-1})$$

$$P_{cu} = A_e F_{cf} = A_e \alpha \phi_f F_{yf} \quad (\text{AASHTO 6.13.6.1.4c})$$

where A_e is the smaller effective area for the flange on either side of the splice.

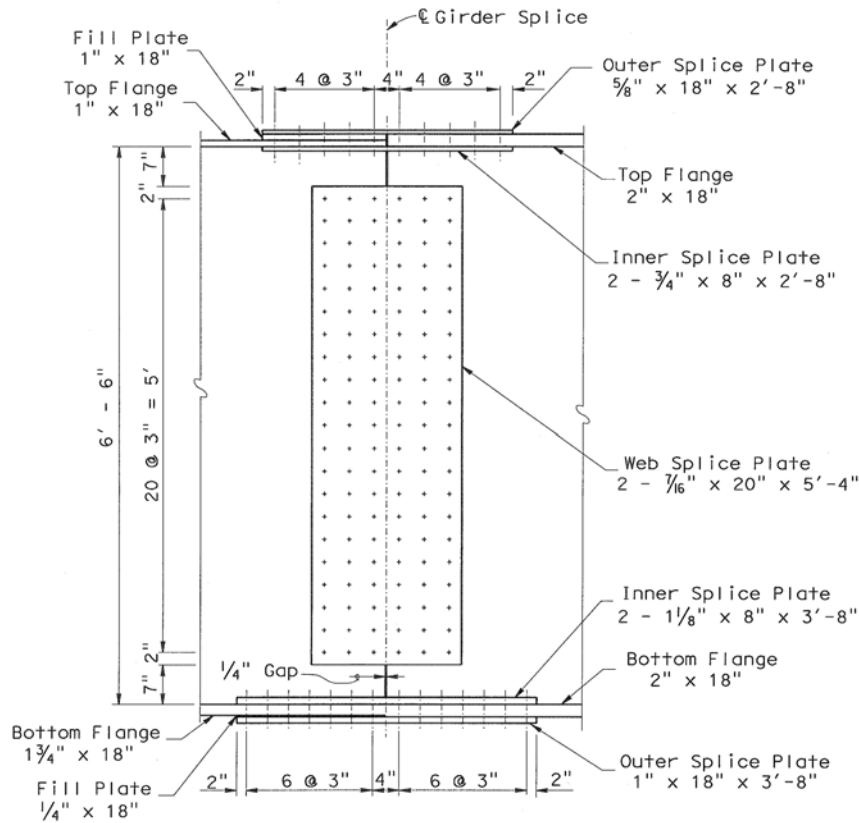

Figure 9.7-15 Bolted Field Girder Splice

$$A_e = \left(\frac{\phi_u F_u}{\phi_y F_{yt}} \right) A_n \leq A_g \quad (\text{AASHTO 6.13.6.1.4c-2})$$

$\alpha = 1.0$ except that a lower value equal to (F_n/F_{yf}) may be used.

Try 4 – 7/8 in. diameter/row for the flange splices. For smaller flange, we have:

$$A_n = [18 - (4)(0.9375)](1.75) = 24.94 \text{ in.}^2$$

$$A_g = (18)(1.75) = 31.5 \text{ in.}^2$$

$$\therefore A_e = \left(\frac{\phi_u F_u}{\phi_f F_{yt}} \right) A_n = \left(\frac{(0.8)(65)}{(0.95)(50)} \right) (24.94) = 27.30 \text{ in.}^2 < A_g = 31.5 \text{ in.}^2$$

Use $A_e = 27.30 \text{ in.}^2$

$$P_{cu} = A_e \alpha \phi_f F_{yf} = (27.30)(1.0)(1.0)(50) = 1,365.0 \text{ kips}$$

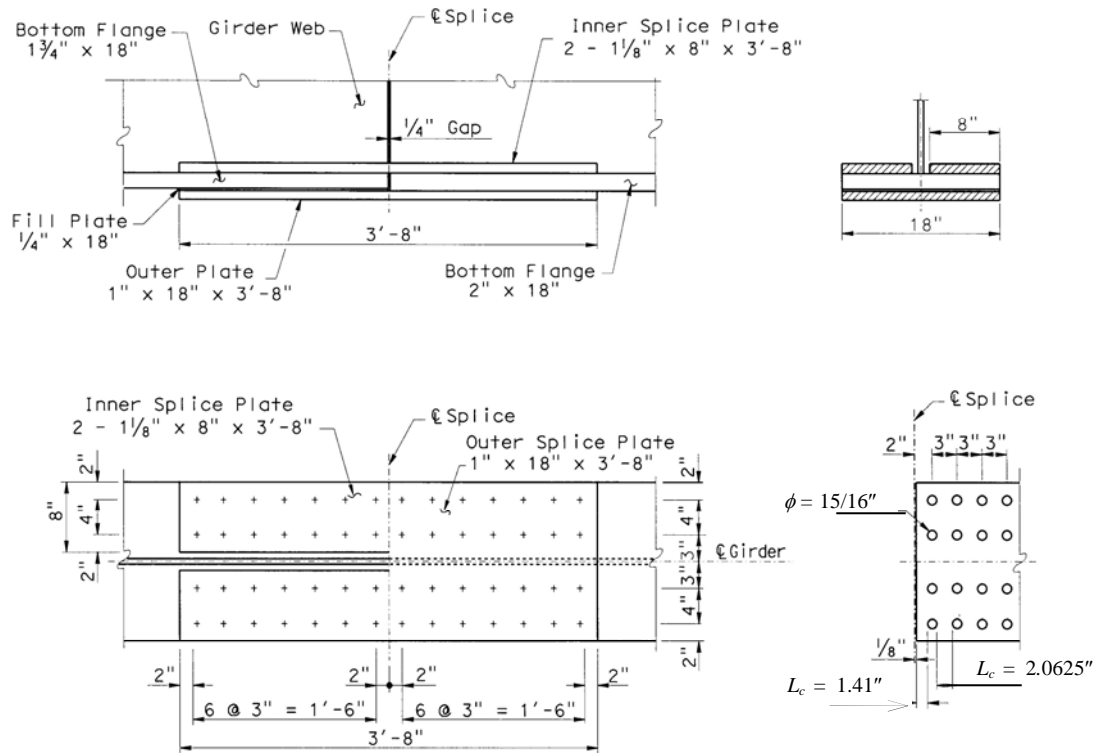

Figure 9.7-16 Bottom Flange Splice

- Determine Nominal Resistance per Bolt

When the length between the extreme fasteners measured parallel to the line of action of the force is less than 50 in. the nominal shear resistance for an A325 – 7/8 in. diameter bolt is:

$$R_n = 0.48A_b F_{ub} N_s \quad (\text{AASHTO 6.13.2.7-1})$$

$$A_b = (0.875 / 2)^2 \pi = 0.6 \text{ in.}^2$$

$$F_{ub} = 120 \text{ ksi} \quad (\text{AASHTO 6.4.3.1})$$

$$N_s = 2 \text{ (for double shear)}$$

$$R_n = (0.48)(0.6)(120)(2) = 69.1 \text{ kips}$$

Since the clear end distance $L_c = 1.875 - 0.469 = 1.41 \text{ in.} < 2d = 1.75 \text{ in.}$ (Figure 9.7-16), the nominal bearing resistance for each bolt hole on flange material is:

$$R_n = 1.2L_c t F_u \quad (\text{AASHTO 6.13.2.9-2})$$

$$R_n = (1.2)(1.41)(1.75)(65) = 192.5 \text{ kips}$$

It is obvious that shear resistance controls and design resistance per bolt is 69.1 kips.

- Evaluate Fill Plate Effects

AASHTO 6.13.6.1.5 specifies that fillers ¼ inch and thicker need not be extended and developed provided that the factored shear resistance of the bolts at the strength limit state is reduced by the reduction factor R .

$$R = \frac{1 + (A_f / A_p)}{1 + 2(A_f / A_p)} \quad (\text{AASHTO 6.13.6.1.5-1})$$

A_f = sum of area of the fillers on the top and bottom of the connected plate

A_p = smaller of either the connected plate area or the sum of the splice plate area on the top and bottom of the connected plate

$$A_f = (0.25)(18) = 4.5 \text{ in.}^2$$

$$A_p = \text{smaller of } \left\{ \begin{array}{l} (1.75)(18) = 31.5 \text{ in.}^2 \\ 2(1.125)(8) + (1)(18) = 36.0 \text{ in.}^2 \end{array} \right\} = 31.5 \text{ in.}^2$$

$$R = \frac{1 + (A_f / A_p)}{1 + 2(A_f / A_p)} = \frac{1 + 4.5 / 31.5}{1 + (2)(4.5 / 31.5)} = 0.889$$

- Determine Number of Bolts Required

The number of bolts required is:

$$N = \frac{P_{cu}}{\phi_s R R_n} = \frac{1,365.0}{(0.8)(0.889)(69.1)} = 27.78 \text{ bolts}$$

Use 28 bolts as shown in Figure 9.7-16.

Check Slip Resistance of Bolts – Service Limit State II and Constructibility

AASHTO 6.13.2.1.1 and 6.13.6.1.4a require that the bolted connections shall be proportioned to prevent slip at the service limit state II and during erection of the steel and during the casting or placing of the deck.

- Determine Factored Moments

For the Service II, factored moment at 0.7 Point of Span 2 is obtained from Table 9.7-13.

$$+ M_u = 1,434 + 118 + 280 + 2,784 = 4,616 \text{ kip - ft}$$

$$- M_u = 1,434 + 118 + 280 - 1,094 = 738 \text{ kip - ft}$$

For constructibility, factored dead load moment during the casting of the deck at 0.7 Point of Span 2 is obtained as:

$$M_{DL} = (1.0)(1,434) = 1,434 \text{ kip-ft}$$

It is clear that the Service II moment governs the design.

- Check Slip Resistance

Assume a non-composite section conservatively at the splice location and use the smaller section property for the bottom flange $S_{NCb} = 2,837 \text{ in.}^3$ (Table 9.7-15).

$$F_s = \frac{f_s}{R_h} = \frac{M_u / S_{NCb}}{R_h} = \frac{4,616(12) / 2,837}{1.0} = 19.28 \text{ ksi}$$

$$R_u = F_s A_g = (19.28)(31.5) = 607.3 \text{ kips}$$

Nominal slip resistance per bolt is:

$$R_n = K_h K_s N_s P_t \quad (\text{AASHTO 6.13.2.8-1})$$

where K_h is hole size factor and is equal to 1.0 for the standard hole (AASHTO Table 6.13.2.8-2); K_s is surface condition factor and is taken 0.5 for Class B surface condition (AASHTO Table 6.13.2.8-3); P_t is minimum required bolt tension and is equal to 39 kips (AASHTO Table 6.13.2.8-1). According to AASHTO 6.13.2.2, factored slip resistance of 28 bolts is:

$$R_r = R_n = (1.0)(0.5)(2)(39)(28) = 1,092 \text{ kips} > R_u = 607.3 \text{ kips} \quad \text{O.K.}$$

Check Tensile Resistance of Splice Plates

Since areas of the inner and outer plates are the same, the flange design force is assumed to be divided equally to the inner and outer plates. In the following, splice plates are checked for yielding on the gross section, fracture on the net section, and block shear rupture (AASHTO 6.13.5.2).

- Yielding on Gross Section

$$A_g = (18)(1.0) + (2)(8)(1.125) = 36 \text{ in.}^2$$

$$R_r = \phi_y A_g F_{yf} = (0.95)(36)(50) = 1,710.0 \text{ kips} \quad (\text{AASHTO 6.8.2.1-1})$$

$$R_r = 1,710.0 \text{ kips} > P_{cu} = 1,365.0 \text{ kips} \quad \text{O.K.}$$

- Fracture on Net Section

Inner plates:

$$A_n = (2)[8 - (2)(0.9375)](1.125) = 13.78 \text{ in.}^2$$

$$R_r = \phi_u F_u A_n U = (0.8)(65)(13.78)(1.0) = 715.0 \text{ kips} \quad (\text{AASHTO 6.8.2.1-2})$$

$$R_r = 715.0 \text{ kips} > \frac{P_{cu}}{2} = \frac{1,365.0}{2} = 682.5 \text{ kips} \quad \text{O.K.}$$

Outer plate:

$$A_n = [18 - (4)(0.9375)](1.0) = 14.25 \text{ in.}^2$$

$$R_r = \phi_u F_u A_n U = (0.8)(65)(14.25)(1.0) = 741.0 \text{ kips} \quad (\text{AASHTO 6.8.2.1-2})$$

$$R_r = 741.0 \text{ kips} > \frac{P_{cu}}{2} = 682.5 \text{ kips} \quad \text{O.K.}$$

- Block Shear Rupture

Assume bolt holes are drilled full size, reduction factor for hole, R_p is taken equal to 1.0 (AASHTO 6.13.4). For flange splice plates, reduction factor for block shear rupture, U_{bs} is taken equal to 1.0 (AASHTO 6.13.4). Bolt pattern and block shear rupture failure planes on the inner and outer splice plates are shown in Figure 9.7-17.

Inner plates:

$$A_m = 2 [6 - 1.5(1.0)](0.9375) = 10.34 \text{ in.}^2$$

$$A_{vn} = 2 [20 - 6.5(0.9375)](1.125) = 31.29 \text{ in.}^2$$

$$A_{vg} = 2(20)(1.125) = 45.0 \text{ in.}^2$$

$$\therefore F_u A_{vn} = (65)(31.29) = 2,033.9 \text{ kips} < F_y A_{vg} = (50)(45.0) = 2,250.0 \text{ kips}$$

$$R_r = \phi_{bs} R_p (0.58 F_u A_{vn} + U_{bs} F_u A_m)$$

$$= 0.8(1.0)[(0.58)(65)(31.29) + (1.0)(65)(10.34)] = 1,481.4 \text{ kips} \quad (\text{AASHTO 6.13.4-1})$$

$$R_r = 1,481.4 \text{ kips} > \frac{P_{cu}}{2} = 682.5 \text{ kips} \quad \text{O.K.}$$

Outer plate:

$$A_m = 2 [6 - 1.5(0.9375)](1.0) = 9.19 \text{ in.}^2$$

$$A_{vn} = 2 [20 - 6.5(0.9375)](1.0) = 27.81 \text{ in.}^2$$

$$A_{vg} = 2(20)(1.0) = 40.0 \text{ in.}^2$$

$$\therefore F_u A_{vn} = (65)(27.81) = 1,807.7 \text{ kips} < F_y A_{vg} = (50)(40.0) = 2,000.0 \text{ kips}$$

$$R_r = \phi_{bs} R_p (0.58 F_u A_{vn} + U_{bs} F_u A_m)$$

$$= 0.8(1.0)[(0.58)(65)(27.81) + (1.0)(65)(9.19)] = 1,316.6 \text{ kips} \quad (\text{AASHTO 6.13.4-1})$$

$$R_r = 1,316.6 \text{ kips} > \frac{P_{cu}}{2} = 682.5 \text{ kips} \quad \text{O.K.}$$

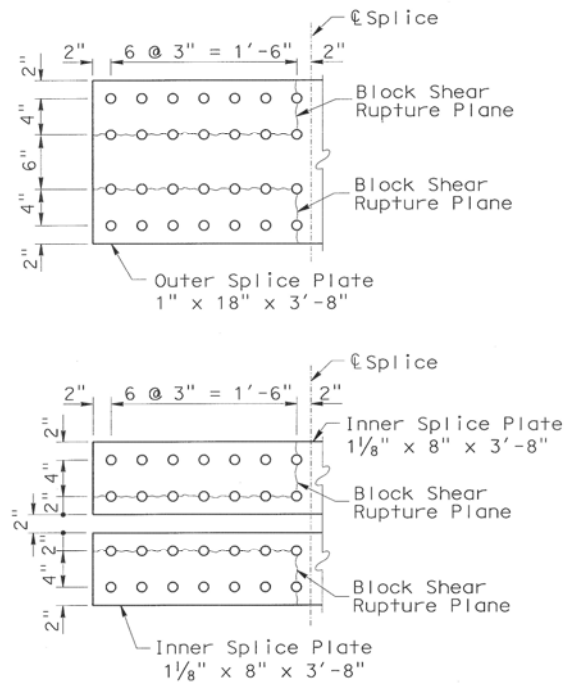

Figure 9.7-17 Block Shear Rupture - Bottom Flange Splice Plates

Check Fracture on Net Section and Block Shear Rupture for Flange

- Fracture on Net Section
 Since the design force is actually based on fracture resistance on the net section, there is no need to check.
- Block Shear Rupture
 Bolt pattern and block shear rupture failure planes on the bottom flange are assumed in Figure 9.7-18.

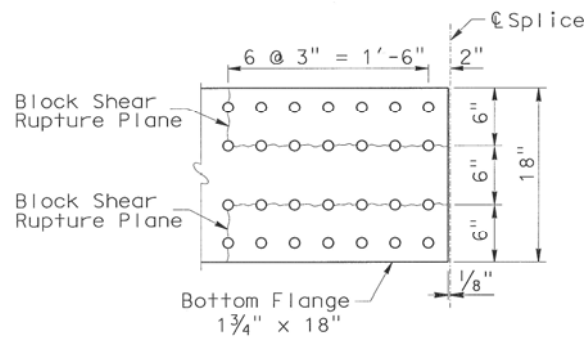

Figure 9.7-18 Block Shear Rupture – Bottom Flange

$$A_{tn} = 2 [6 - 1.5(0.9375)](1.75) = 16.08 \text{ in.}^2$$

$$A_{vn} = 2 [19.875 - 6.5(0.9375)](1.75) = 48.23 \text{ in.}^2$$

$$A_{vg} = 2(19.875)(1.75) = 69.56 \text{ in.}^2$$

$$\therefore F_u A_{vn} = (65)(48.23) = 3,135.0 \text{ kips} < F_y A_{vg} = (50)(69.56) = 3,478.0 \text{ kips}$$

$$R_r = \phi_{bs} R_p (0.58 F_u A_{vn} + U_{bs} F_u A_{tn})$$

$$= 0.8(1.0)[(0.58)(65)(48.23) + (1.0)(65)(16.08)] = 2,290.8 \text{ kips}$$

(AASHTO 6.13.4-1)

$$R_r = 2,290.8 \text{ kips} > P_{cu} = 1,365.0 \text{ kips} \quad \text{O.K.}$$

Check Fatigue for Splice Plates

Fatigue stress ranges in base metal of the bottom flange splice plates adjacent to the slip-critical connections are checked for Category B (AASHTO Table 6.6.1.2.3-1). Fatigue normally does not govern the design of splice plates when combined area of inner and outer splice plates is larger than the area of the smaller flange spliced. The fatigue moment ranges at 0.7 Point of Span 2 are obtained from Tables 9.7-11 and 9.7-12. The nominal fatigue resistance is calculated in Table 6.8.2 in Chapter 6. The flexural stresses at the edges of the splice plates are assumed to be the same as the flexural stresses in the girder at those locations. The gross section of the smaller girder section is used to calculate the stresses. Properties of the steel section alone are used conservatively. For the smaller spliced section (Table 9.7-15), $S_{NCb} = 2,837 \text{ in.}^3$

Fatigue I - HL-93 Truck for infinite life:

$$\gamma(\Delta f) = \frac{\gamma(\Delta M)}{S_{NCb}} = \frac{1,440(12)}{2,837}$$

$$= 6.09 \text{ ksi} < 16.0 \text{ ksi} \quad \text{O.K. for Category B}$$

Fatigue II - P-9 Truck for finite life:

$$\gamma(\Delta f) = \frac{\gamma(\Delta M)}{S_{NCb}} = \frac{2,396(12)}{2,837}$$

$$= 10.13 \text{ ksi} < 30.15 \text{ ksi} \quad \text{O.K. for Category B}$$

9.7.15.3 Design Top Flange Splices

Try one outer splice plate 5/8 in. × 18 in., two inner plates 3/4 in. × 8 in., and one fill plate 1 in. × 18 in. as shown in Figure 9.7-19.

As the same as the bottom flange, try A325 high-strength $d = 7/8$ in. bolt threads excluded with bolt spacing of 3 in. and edge distance of 2 inches.

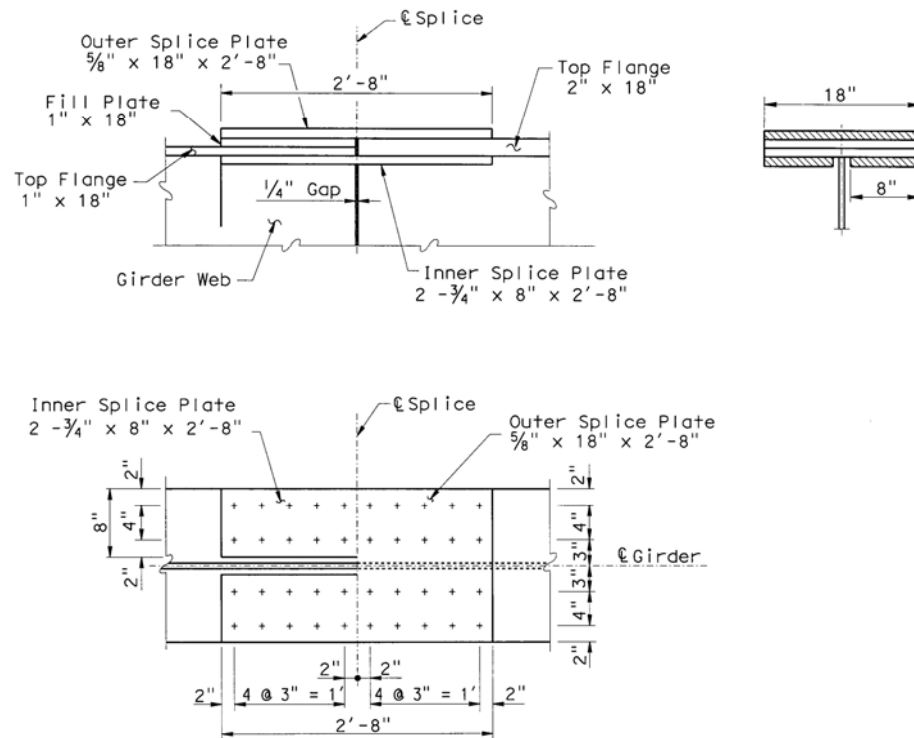

Figure 9.7-19 Top Flange Splice

Determine Number of Bolts Required – Strength Limit State

- Determine Design Forces

Try 4 – 7/8 in. diameter/row for the flange splices. For the smaller flange, we have:

$$A_n = [18 - (4)(0.9375)](1.0) = 14.25 \text{ in.}^2$$

$$A_g = (18)(1.0) = 18 \text{ in.}^2$$

$$\therefore A_e = \left(\frac{\phi_u F_u}{\phi_y F_{yt}} \right) A_n = \left(\frac{(0.8)(65)}{(0.95)(50)} \right) (14.25) = 15.60 \text{ in.}^2 < A_g = 18 \text{ in.}^2$$

(AASHTO 6.13.6.1.4c-2)

Use $A_e = 15.60 \text{ in.}^2$

$$P_{cu} = A_e \alpha \phi_f F_{yf} = (15.60)(1.0)(1.0)(50) = 780.0 \text{ kips}$$

- Determine Nominal Resistance per Bolt

As calculated in Section 9.7.15.2, the nominal shear resistance per A325 – 7/8 in. diameter bolt in double shear is:

$$R_n = 69.1 \text{ kips}$$

The nominal bearing resistance for each bolt hole on flange material is:

$$R_n = 1.2L_c t F_u \quad (\text{AASHTO 6.13.2.9-2})$$

For exterior hole: $L_c = 1.875 - 0.469 = 1.41 \text{ in.}$

$$R_n = (1.2)(1.41)(1.0)(65) = 110.0 \text{ kips}$$

It is obvious that shear resistance controls and design resistance per bolt is 69.1 kips.

- Evaluate Fill Plate Effects

AASHTO 6.13.6.1.5 specifies that fillers $\frac{1}{4}$ inch and thicker need not be extended and developed provided that the factored shear resistance of the bolts at the strength limit state is reduced by the reduction factor R :

$$R = \frac{1 + (A_f / A_p)}{1 + 2(A_f / A_p)} \quad (\text{AASHTO 6.13.6.1.5-1})$$

$$A_f = (1.0)(18) = 18 \text{ in.}^2$$

$$A_p = \text{smaller of } \left\{ \begin{array}{l} 1.0(18) = 18 \text{ in.}^2 \\ 2(0.75)(8) + (0.625)(18) = 23.25 \text{ in.}^2 \end{array} \right\} = 18 \text{ in.}^2$$

$$R = \frac{1 + (A_f / A_p)}{1 + 2(A_f / A_p)} = \frac{1 + 18/18}{1 + (2)(18/18)} = 0.667$$

- Determine Number of Bolts Required

The number of bolts required is

$$N = \frac{P_{cu}}{\phi_s R R_n} = \frac{780.0}{(0.8)(0.667)(69.1)} = 21.5 \text{ bolts;}$$

N is only 5.8% over 20 bolts shown in Figure 9.7-19, say O.K for this example. However, engineer should redesign the top flange splices for actual projects.

Check Slip Resistance of Bolts – Service Limit State II and Constructibility

From Section 9.7.15.2, the moment at Service II is 1,773 kip-ft. Assume non-composite section conservatively at the splice location and use the smaller section property for the top flange $S_{NCt} = 2,193 \text{ in.}^3$ (Table 9.7-15). Slip force is calculated as follows:

$$F_s = \frac{f_s}{R_h} = \frac{M_u / S_{NCb}}{R_h} = \frac{4,616(12) / 2,193}{1.0} = 25.26 \text{ ksi} \quad (\text{CA 6.13.6.1.4c-5})$$

$$R_u = F_s A_g = (25.26)(18) = 454.7 \text{ kips}$$

Nominal slip resistance per bolt is:

$$R_n = K_h K_s N_s P_t \quad (\text{AASHTO 6.13.2.8-1})$$

Slip resistance of 20 bolts is:

$$R_r = R_n = (1.0)(0.5)(2)(39)(20) = 780.0 \text{ kips} > R_u = 454.7 \text{ kips} \quad \text{O.K.}$$

Check Tensile Resistance of Splice Plates

Since areas of the inner and outer plates differ less than 10%, the flange design force is assumed to be divided equally to the inner and outer plates. In the following, splice plates are checked for yielding on the gross section, fracture on the net section, and block shear rupture (AASHTO 6.13.5.2).

- Yielding on Gross Section

$$A_g = (18)(0.625) + (2)(8)(0.75) = 23.25 \text{ in.}^2$$

$$R_r = \phi_y A_g F_{yf} = (0.95)(23.25)(50) = 1,104.4 \text{ kips} \quad (\text{AASHTO 6.8.2.1-1})$$

$$R_r = 1,104.4 \text{ kips} > P_{cu} = 780.0 \text{ kips} \quad \text{O.K.}$$

- Fracture on Net Section

Inner plates:

$$A_n = (2)[8 - (2)(0.9375)](0.75) = 9.19 \text{ in.}^2$$

$$R_r = \phi_u F_u A_n U = (0.8)(65)(9.19)(1.0) = 477.9 \text{ kips} \quad (\text{AASHTO 6.8.2.1-2})$$

$$R_r = 477.9 \text{ kips} > \frac{P_{cu}}{2} = \frac{780.0}{2} = 390.0 \text{ kips} \quad \text{O.K.}$$

Outer plate:

$$A_n = [18 - (4)(0.9375)](0.625) = 8.91 \text{ in.}^2$$

$$R_r = \phi_u F_u A_n U = (0.8)(65)(8.91)(1.0) = 463.3 \text{ kips} \quad (\text{AASHTO 6.8.2.1-2})$$

$$R_r = 463.3 \text{ kips} > \frac{P_{cu}}{2} = 390.0 \text{ kips} \quad \text{O.K.}$$

- Block Shear Rupture

The bolt pattern and block shear rupture failure planes on the inner and outer splice plates are assumed in Figure 9.7-20.

Inner Plates:

$$A_m = 2 [6 - 1.5(0.9375)](0.75) = 6.89 \text{ in.}^2$$

$$A_{vn} = 2 [14 - 4.5(0.9375)](0.75) = 14.67 \text{ in.}^2$$

$$A_{vg} = 2(14)(0.75) = 21.0 \text{ in.}^2$$

$$\begin{aligned} \therefore F_u A_{vn} &= (65)(14.67) = 953.6 \text{ kips} < F_y A_{vg} = (50)(21.0) = 1,050.0 \text{ kips} \\ R_r &= \phi_{bs} R_p (0.58 F_u A_{vn} + U_{bs} F_u A_m) \\ &= 0.8(1.0)[(0.58)(65)(14.67) + (1.0)(65)(6.89)] = 800.7 \text{ kips} \quad (\text{AASHTO 6.13.4-1}) \\ R_r &= 800.7 \text{ kips} > \frac{P_{cu}}{2} = 390.0 \text{ kips} \quad \text{O.K.} \end{aligned}$$

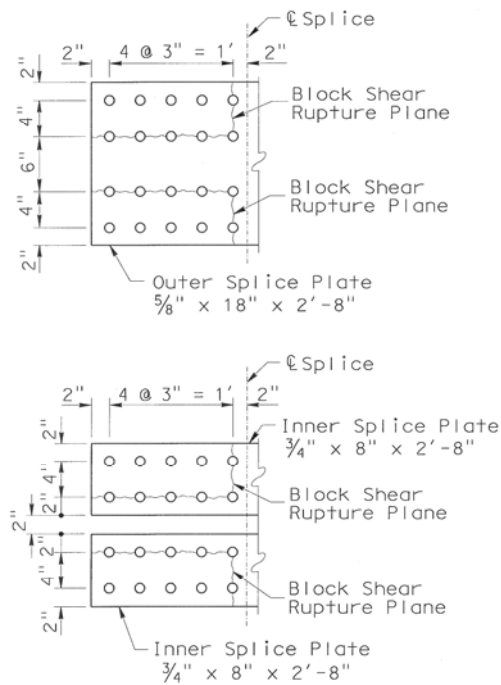

Figure 9.7-20 Block Shear Rupture – Top Flange Splice Plates

Outer plate:

$$\begin{aligned} A_m &= 2 [6 - 1.5(0.9375)](0.625) = 5.74 \text{ in.}^2 \\ A_{vn} &= 2 [14 - 4.5(0.9375)](0.625) = 12.23 \text{ in.}^2 \\ A_{vg} &= 2(14)(0.625) = 17.5 \text{ in.}^2 \\ \therefore F_u A_{vn} &= (65)(12.23) = 795.0 \text{ kips} < F_y A_{vg} = (50)(17.5) = 875.0 \text{ kips} \\ R_r &= \phi_{bs} R_p (0.58 F_u A_{vn} + U_{bs} F_u A_m) \\ &= 0.8(1.0)[(0.58)(65)(12.23) + (1.0)(65)(5.74)] = 667.3 \text{ kips} \quad (\text{AASHTO 6.13.4-1}) \\ R_r &= 667.3 \text{ kips} > \frac{P_{cu}}{2} = 390.0 \text{ kips} \quad \text{O.K.} \end{aligned}$$

Check Fracture on Net Section and Block Shear Rupture for Flange

- Fracture on Net Section

Since the design force is actually based on fracture resistance on the net section, there is no need to check.

- Block Shear Rupture

The bolt pattern and block shear rupture failure planes on the inner and outer splice plates are assumed in Figure 9.7-21.

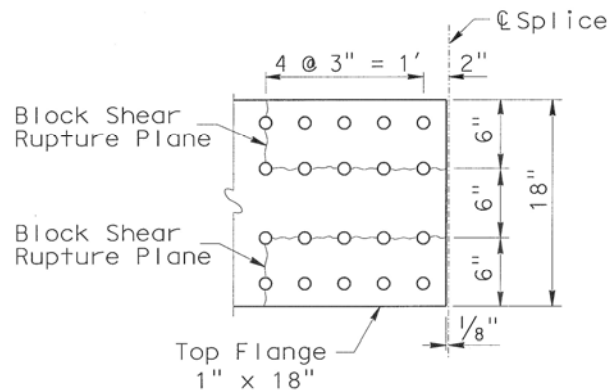

Figure 9.7-21 Block Shear Rupture – Top Flange

$$A_{tn} = 2 [6 - 1.5(0.9375)](1.0) = 9.19 \text{ in.}^2$$

$$A_{vn} = 2 [13.875 - 4.5(0.9375)](1.0) = 19.31 \text{ in.}^2$$

$$A_{vg} = 2(14)(1.0) = 28.0 \text{ in.}^2$$

$$\therefore F_u A_{vn} = (65)(19.31) = 1,255.2 \text{ kips} < F_y A_{vg} = (50)(28.0) = 1,400.0 \text{ kips}$$

$$R_r = \phi_{bs} R_p (0.58 F_u A_{vn} + U_{bs} F_u A_{tn})$$

$$= 0.8(1.0) [(0.58)(65)(19.31) + (1.0)(65)(9.19)] = 1,060.3 \text{ kips}$$

(AASHTO 6.13.4-1)

$$R_r = 1,060.3 \text{ kips} > P_{cu} = 780.0 \text{ kips}$$

O.K.

Check Fatigue for Splice Plates

Fatigue stress ranges in base metal of the top flange splice plates adjacent to the slip-critical connections are checked for Category B (AASHTO Table 6.6.1.2.3-1). The fatigue moment ranges at 0.7 Point are obtained from Tables 9.7-11 and 9.7-12. The nominal fatigue resistance is calculated in Table 9.7-25. The flexural stresses at the edges of the splice plates are assumed to be the same as the flexural stresses in the girder at those locations. Gross section of the smaller girder section is used to calculate the stresses. Properties of the steel section alone are used conservatively. For the smaller spliced section (Table 9.7-15), $S_{NCI} = 2,193 \text{ in.}^3$.

Fatigue I - HL-93 Truck for infinite life:

$$\begin{aligned}\gamma(\Delta f) &= \frac{\gamma(\Delta M)}{S_{NCt}} = \frac{1,440(12)}{2,193} \\ &= 7.88 \text{ ksi} < 16.0 \text{ ksi} \quad \text{O.K. for Category B}\end{aligned}$$

Fatigue II - P-9 Truck for finite life:

$$\begin{aligned}\gamma(\Delta f) &= \frac{\gamma(\Delta M)}{S_{NCb}} = \frac{2,396(12)}{2,193} \\ &= 13.11 \text{ ksi} < 30.15 \text{ ksi} \quad \text{O.K. for Category B}\end{aligned}$$

9.7.15.4 Design Web Splices

Try two 7/16 in. × 64 in. web splice plates and A325 high-strength $d = 7/8$ in. bolt threads excluded with bolt spacing of 3 in. as shown in Figure 9.7-15.

$$A_g = (2)(0.4375)(64) = 56 \text{ in.}^2$$

Check Bolt Shear Resistance - Strength Limit States

- Calculate Design Forces

The design forces for a web splice are shown in Figure 9.7-22.

$$(1) \text{ Shear} \quad V_{uw} = \phi_v V_n \quad (\text{CA 6.13.6.1.4b-1})$$

$$\text{From Section 9.7.11.4, } V_{uw} = \phi_v V_n = 843.6 \text{ kips}$$

- (2) Moment induced by eccentrically loaded shear

$$M_{vw} = V_{uw} e = (843.6)(5.0) = 4,218 \text{ kip-in.}$$

- (3) Moment resisted by the web

Case I – Positive Bending

At the strength limit state, the smaller section at the point of splice is a composite compact section.

$$M_{uw} = \phi_f \frac{t_w F_{yw}}{4} [D^2 - 4y_o^2] \quad (\text{CA C6.13.6.1.4b-1a})$$

y_o is distance from the mid-depth of the web to the plastic neutral axis. From Section 9.7.10.3, since the plastic neutral axis is located in the top flange (Figure 9.7-7), $y_o = d_w = 39.5 \text{ in.} > D/2 = 39 \text{ in.}$ and all the web is in tension, Equation CA-C6.13.6.1.4b-1a is no longer valid and $M_{uw} = 0$.

Case II – Negative Bending

At the strength limit state, the smaller section at the point of splice is a noncompact section.

$$H_{uw} = \phi_f \frac{t_w D^2}{2} (F_{yw} - F_{nc}) = 0 \quad (\text{CA C6.13.6.1.4b-2b})$$

(5) Web design forces

Case I – Positive Bending

Total moment $M_u = M_{uw} + M_{vw} = 0 + 4,218 = 4,218$ kip - in.

Horizontal force $H_{uw} = 2,437.5$ kips

Vertical shear $V_{uw} = 843.6$ kips

Case II – Negative Bending

Total moment $M_u = M_{uw} + M_{vw} = 31,687.5 + 4,218 = 35,906$ kip - in.

Horizontal force $H_{uw} = 0$

Vertical shear $V_{uw} = 843.6$ kips

- Determine Nominal Resistance per Bolt

As calculated in Section 9.7.15.2, the nominal shear resistance per A325 – 7/8 in. diameter bolt in double shear is:

$$R_n = 69.1 \text{ kips}$$

The nominal bearing resistance for each bolt hole on web material is:

$$R_n = 1.2L_c t F_u \quad (\text{AASHTO 6.13.2.9-2})$$

For exterior hole: $L_c = 1.875 - 0.469 = 1.41$ in.

$$R_n = (1.2)(1.41)(0.625)(65) = 68.7 \text{ kips}$$

It is obvious that bearing resistance controls and nominal resistance per bolt is 68.7 kips. It is noted that AASHTO 6.13.2.7 specifies that the nominal shear resistance of a fastener in connections greater than 50 in. in length shall be taken 0.8 times the value given by AASHTO 6.13.2.7-1 and 6.13.2.7-2. Although the vertical length of web splices is greater than 50 in., shear resistance of the bolt is not reduced because the resultant shear applied to the bolts is mainly induced by horizontal force.

- Calculate Polar Moment of Inertia I_p of Bolts With Respect to Neutral Axis of Web Section

It can be seen that the upper and lower right corner bolts are the most highly stressed and will be investigated. The “Vector” method is used to calculate shear force R on the top right bolt.

$$\begin{aligned}
 I_p &= \sum x^2 + \sum y^2 \\
 &= (2)(3)(30^2 + 27^2 + 24^2 + 21^2 + 18^2 + 15^2 + 12^2 + 9^2 + 6^2 + 3^2) \\
 &\quad + (2)(21)(3)^2 = 21,168 \text{ in.}^2
 \end{aligned}$$

- Check Shear Resistance of Lower Right Corner Bolt

Case I - Positive Bending

Factored shear force applied on the lower right corner bolt is:

$$R_x = \frac{M_u y}{I_p} = \frac{4,218(30)}{21,168} = 5.98 \text{ kips } (\rightarrow)$$

$$R_y = \frac{M_u x}{I_p} = \frac{4,218(3)}{21,168} = 0.60 \text{ kips } (\uparrow)$$

$$R_v = \frac{V_{uw}}{(3)(21)} = \frac{843.6}{63} = 13.39 \text{ kips } (\uparrow)$$

$$R_h = \frac{H_{uw}}{(3)(21)} = \frac{2,437.5}{63} = 38.69 \text{ kips } (\rightarrow)$$

$$\begin{aligned}
 R_{bolt} &= \sqrt{(R_h + R_x)^2 + (R_v + R_y)^2} \\
 &= \sqrt{(38.69 + 5.98)^2 + (13.39 + 0.6)^2} \\
 &= 46.81 \text{ kips} < \phi_{bb} R_n = (0.8)(68.7) = 54.96 \text{ kips}
 \end{aligned}$$

O.K.

Case II - Negative Bending

Factored shear forces applied on the lower right corner bolt is:

$$R_x = \frac{M_u y}{I_p} = \frac{35,906(30)}{21,168} = 50.89 \text{ kips } (\leftarrow)$$

$$R_y = \frac{M_u x}{I_p} = \frac{35,906(3)}{21,168} = 5.09 \text{ kips } (\downarrow)$$

$$R_v = \frac{V_{uw}}{(3)(21)} = \frac{843.6}{63} = 13.39 \text{ kips } (\downarrow)$$

$$R_h = \frac{H_{uw}}{(3)(21)} = 0$$

$$\begin{aligned}
 R_{bolt} &= \sqrt{(R_h + R_x)^2 + (R_v + R_y)^2} \\
 &= \sqrt{(0 + 50.89)^2 + (13.39 + 5.09)^2} \\
 &= 54.14 \text{ kips} < \phi_{bb} R_n = (0.8)(68.7) = 54.96 \text{ kips}
 \end{aligned}$$

O.K.

Check Slip of Bolts – Service Limit State II and Constructability

- Determine Factored Moment and Shear

From Section 9.7.15.2, factored moment at 0.7 Point of Span 2 at Service II is:

$$+ M_u = 1,434 + 118 + 280 + 2,784 = 4,616 \text{ kip-ft}$$

From Table 9.7-2, it is obtained

$$\begin{aligned} V_u &= V_{DC1} + V_{DC2} + V_{DW} + (1.3)DF_v(LL + IM)_{HL-93} \\ &= (-68.8) + (-5.6) + (-13.4) + (1.3)(1.082)(-92.7) = -218.2 \text{ kips} \end{aligned}$$

Moment due to eccentrically loaded shear is:

$$M_{vu} = V_u e = (218.2)(5) = 1,091.0 \text{ kip-in.}$$

Moment resisted by the web at Service II

$$M_{uw} = \frac{t_w D^2}{12} |f_s - f_{os}| \quad (\text{CA C6.13.6.1.4b-1c})$$

f_s is maximum flexural stress due to Service II at the extreme fiber of the flange and f_{os} is flexural stress due to Service II at the extreme fiber of the other flange concurrent with f_s . Assume non-composite section at the splice location, we have

$$f_s = \frac{M_u}{S_{NCt}} = \frac{4,616(12)}{2,193} = 25.26 \text{ ksi} \quad (\text{Compression})$$

$$f_{os} = \frac{M_u}{S_{NCb}} = \frac{4,616(12)}{2,837} = 19.52 \text{ ksi} \quad (\text{Tension})$$

$$\begin{aligned} M_{uw} &= \frac{t_w D^2}{12} |f_s - f_{os}| \\ &= \frac{(0.625)(78)^2}{12} |-25.26 - 19.52| = 14,189.7 \text{ kips-in.} \end{aligned}$$

Horizontal force at web

$$\begin{aligned} H_{uw} &= \frac{t_w D}{2} (f_s + f_{os}) \\ &= \frac{(0.625)(78)}{2} (-25.26 + 19.52) = -139.9 \text{ kips} \end{aligned} \quad (\text{CA C6.13.6.1.4b-2c})$$

- Calculate Factored Shear Forces Applied on Upper Right Corner Bolt

$$R_x = \frac{(M_{vw} + M_{uw})y}{I_p} = \frac{(1,091.0 + 14,189.7)(30)}{21,168} = 21.66 \text{ kips} \quad (\leftarrow)$$

$$R_y = \frac{(M_{vw} + M_{uw})x}{I_p} = \frac{(1,091.0 + 14,189.7)(3)}{21,168} = 2.17 \text{ kips } (\uparrow)$$

$$R_v = \frac{V_u}{(3)(21)} = \frac{218.2}{63} = 3.46 \text{ kips } (\uparrow)$$

$$R_h = \frac{H_{uw}}{(3)(21)} = \frac{139.9}{63} = 2.22 \text{ kips } (\leftarrow)$$

$$\begin{aligned} R_u &= \sqrt{(R_h + R_x)^2 + (R_v + R_y)^2} \\ &= \sqrt{(2.22 + 21.66)^2 + (3.46 + 2.17)^2} \\ &= 24.53 \text{ kips} \end{aligned}$$

- Check Slip Resistance

From Section 9.7.15.2, slip resistance of one bolt is:

$$R_r = R_n = (1.0)(0.5)(2)(39) = 39.0 \text{ kips} > R_u = 24.53 \text{ kips} \quad \text{O.K.}$$

Check Splice Plates

- Check Shear Resistance

(1) Yielding on the gross section:

$$\begin{aligned} V_r &= \phi_v (0.58 A_g F_w) = (1.0)(0.58)(2 \times 0.4375 \times 64)(50) \\ &= 1,624 \text{ kips} > V_{uw} = 843.6 \text{ kips} \end{aligned} \quad \text{O.K.}$$

(2) Fracture on net section:

$$\begin{aligned} A_n &= 2 [64 - 21(0.9375)](0.4375) = 38.77 \text{ in.}^2 \\ V_r &= \phi_u (0.58 F_u A_n) = (0.8)(0.58)(65)(38.77) \\ &= 1,169.3 \text{ kips} > V_{uw} = 843.6 \text{ kips} \end{aligned} \quad \text{O.K.}$$

(3) Block shear rupture

The bolt pattern and block shear rupture failure planes on the inner and outer splice plates are assumed in Figure 9.7-23.

$$A_m = 2 [8 - 2.5(0.9375)](0.4375) = 4.95 \text{ in.}^2$$

$$A_{vn} = 2 [62 - 20.5(0.9375)](0.4375) = 37.43 \text{ in.}^2$$

$$A_{vg} = 2(62)(0.4375) = 54.25 \text{ in.}^2$$

$$\therefore F_u A_{vn} = (65)(37.43) = 2,433.0 \text{ kips} < F_y A_{vg} = (50)(54.25) = 2,712.5 \text{ kips}$$

$$\begin{aligned}
 R_r &= \phi_{bs} R_p (0.58 F_u A_{vn} + U_{bs} F_u A_m) \\
 &= 0.8(1.0) [(0.58)(65)(37.43) + (1.0)(50)(4.95)] = 1,326.9 \text{ kips}
 \end{aligned}$$

(AASHTO 6.13.4-1)

$$R_r = 1,326.9 \text{ kips} > V_{uw} = 843.6 \text{ kips} \quad \text{O.K.}$$

- Check Flexural Resistance

Moment of inertia of the splice plates about N.A. of the web section is:

$$I_w = (2) \left(\frac{(0.4375)(64)^3}{12} \right) = 19,115 \text{ in.}^4$$

$$f_b = \frac{M_u C}{I_{sp}} = \frac{4,218(32)}{19,115} = 7.06 \text{ ksi} < F_y = 50 \text{ ksi} \quad \text{O.K.}$$

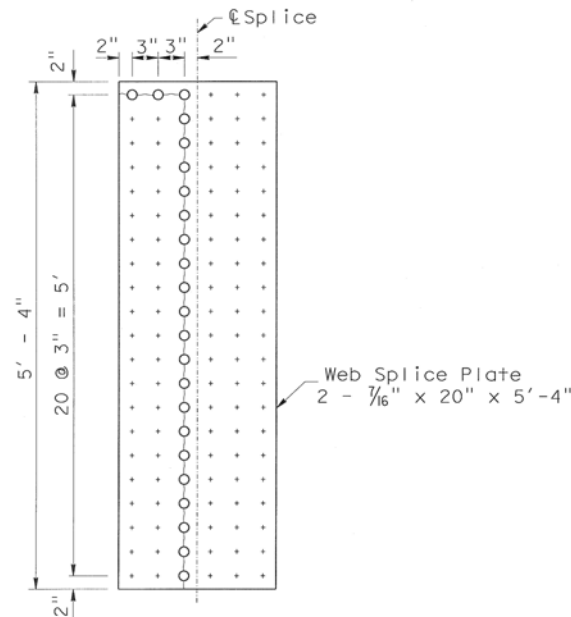

Figure 9.7-23 Block Shear Rupture – Web Splice Plates

Check Fatigue Stress Ranges

From AASHTO Table 6.6.1.2.3-1, Category B shall be used for base metal at the gross section of the high-strength bolted slip-critical resistant section. Similar assumptions used for flange splices are used for the web splice plates. Flexural stress ranges at the web splice plates are induced by the positive-negative fatigue moments and moments due to the eccentricity of the fatigue shear forces from the centerline of the splices to the center of gravity of the web-splice bolt group. Positive moments are assumed to be applied to the short-term composite section and negative moments are assumed to be applied to the steel section alone in the splice location. Eccentric

moments of the fatigue shear forces are assumed to be applied to the gross section of the web splice plates. For the smaller spliced section, $I_{NC} = 99,872 \text{ in.}^4$ (Table 9.7-15), and $I_{ST} = 275,267 \text{ in.}^4$ (Table 9.7-17). Refer to Tables 9.7-15 and 9.7-17, and Figure 9.7-22, at the locations of the edges of the web splice plates, elastic section modulus for the short-term composite section, the steel section, and the web splice plates are calculated as follows:

$$S_{ST-wb} = \frac{I_{ST}}{C_{splice-bot}} = \frac{275,267}{(y_{STb} - t_{bf} - 7)} = \frac{275,267}{(68.51 - 1.75 - 7)} = 4,606 \text{ in.}^3$$

$$S_{ST-wt} = \frac{I_{ST}}{C_{splice-top}} = \frac{275,267}{(y_{STt} - t_{tf} - 7)} = \frac{275,267}{(12.24 - 1.0 - 7)} = 64,921 \text{ in.}^3$$

$$S_{NC-wb} = \frac{I_{NC}}{C_{splice-bot}} = \frac{99,872}{(y_{NCb} - t_{bf} - 7)} = \frac{99,872}{(35.2 - 1.75 - 7)} = 3,776 \text{ in.}^3$$

$$S_{NC-wt} = \frac{I_{NC}}{C_{splice-top}} = \frac{99,872}{(y_{NCT} - t_{tf} - 7)} = \frac{99,872}{(45.55 - 1.0 - 7)} = 2,660 \text{ in.}^3$$

$$S_{w-splice} = (2) \frac{(0.4375)(64)^2}{6} = 597 \text{ in.}^3$$

It is seen that the bottom edge of the web splice plate obviously controls design and is, therefore, checked. Flexural stress ranges due to fatigue moments (Tables 9.7-11 and 9.7-12) and eccentric moments of the fatigue shear forces (Tables 9.7-11 and 9.7-12) are:

Fatigue I - HL-93 Truck for infinite life:

$$\begin{aligned} \gamma(\Delta f) &= \left| \frac{+M}{S_{ST-wb}} \right| + \left| \frac{-M}{S_{NT-wb}} \right| + \frac{[(+V) - (-V)]e}{S_{w-splice}} \\ &= \frac{(1,042)(12)}{4,606} + \frac{(398)(12)}{3,776} + \frac{(16.5 + 60.8)(5)}{597} \\ &= 2.71 + 1.26 + 0.65 = 4.62 \text{ ksi} < 16.0 \text{ ksi} \quad \text{O.K. for Category B} \end{aligned}$$

Fatigue II - P-9 Truck for finite life:

$$\begin{aligned} \gamma(\Delta f) &= \left| \frac{+M}{S_{ST-wb}} \right| + \left| \frac{-M}{S_{NT-wb}} \right| + \frac{[(+V) - (-V)]e}{S_{w-splice}} \\ &= \frac{(1,693)(12)}{4,606} + \frac{(703)(12)}{3,776} + \frac{(21.1 + 97.9)(5)}{597} \\ &= 4.41 + 2.23 + 1.00 = 7.64 \text{ ksi} < 30.15 \text{ ksi} \quad \text{O.K. for Category B} \end{aligned}$$

9.7.16 Calculate Deflection and Camber

9.7.16.1 Determine Stiffness of Girders

AASHTO 2.5.2.6.2 specifies that for composite design, the stiffness of the design cross-section used for the determination of deflection should include the entire width of the roadway and the structurally continuous portions of the railing, sidewalks, and median barriers. AASHTO C6.10.1.5 states that the stiffness properties of the steel section alone for the loads applied to noncomposite sections, the stiffness properties of the long-term composite section for permanent loads applied to composite sections and the stiffness properties of the short-term composite section properties for transient loads, shall be used over the entire bridge length, respectively.

In this example, section properties of the steel section alone, the short-term section and the long-term composite sections are calculated in Tables 9.7-15 to 9.7-18, and Tables 9.7-21 to 9.7-24.

9.7.16.2 Calculate Vehicular Load Deflections

AASHTO 2.5.2.6.2 specifies that the maximum absolute deflection of the straight girder systems should be based on all design lanes loaded by HL93 including dynamic load allowance (Service I load combination) and all supporting components deflected equally.

$$\begin{aligned} \text{Number of traffic lanes} &= (\text{deck width} - \text{barrier width})/12 \\ &= [58 - 2(1.42)]/12 = 4.596 \end{aligned}$$

$$\therefore \text{Number of design traffic lanes} = 4$$

For this five-girder bridge, each girder will carry 0.8 design traffic lane equally. Assume that the exterior girders have the same section properties as the interior girders, and use properties of the short-term composite sections of interior girder as shown in Tables 9.7-17 and 9.7-18, vehicular live load deflections are calculated and listed in Table 9.7-27. Comparisons with the AASHTO 2.5.2.6.2 requirement of the vehicular load deflection limit $L/800$ are also made in Table 9.7-27.

Table 9.7-27 Live Load Deflections for Interior Girder

Span	L (ft)	Vehicular Load Deflection (in.)	AASHTO Deflection Limit $L/800$ (in.)	Check
1	110	0.211	1.650	O.K.
2	165	0.305	2.475	O.K.
3	125	0.468	1.875	O.K.

9.7.16.3 Calculate Camber

Camber of a structural member is defined as the difference between the shape of the member (the final geometric profile/grade of the member) under full dead load and normal temperature, and its shape at the no-load condition and shop temperature as discussed in MTD 12-3 (Caltrans, 2004b). For a steel-concrete composite girder, camber is the curvature/deformation induced by a fabrication process to compensate for dead load deflections.

Camber of a steel-concrete composite girder includes three components: Deck Slab Dead Load, Steel Girder Dead Load, and Added Dead Load. Each camber component has the same magnitude and opposite direction with its respective deflection component.

Deck Slab Dead Load and Steel Girder Dead Load deflections are due to the weight of the deck slab, stay-in-place deck form and steel girder, respectively. For unshored construction, it is assumed that all deck concrete is placed at once and deck slab dead load and steel girder dead load are applied to the steel girder section alone (Tables 9.7-15 and 9.7-21). An additional 10% more deflection shall be added to the deck slab dead load deflection to consider deflection induced by concrete shrinkage effects as specified in MTD 12-3 (Caltrans, 2004b). Added Dead Load deflection is due to weight of the curb, railing, utilities, and future AC overlay. Added dead load is applied to the long-term composite section girder (Tables 9.7-18 and 9.7-24).

Camber diagram for each girder shall be presented in the design plan. Figure 9.7-24 shows the camber diagram of the interior girder.

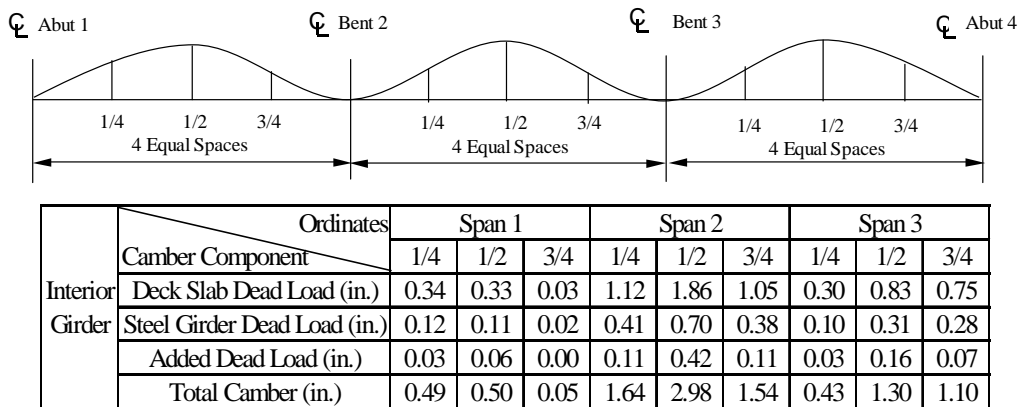
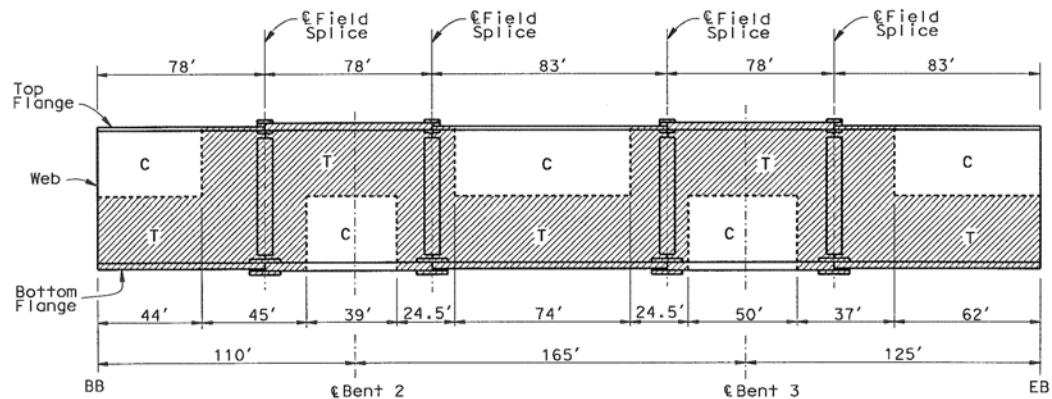

Figure 9.7-24 Camber Diagram of Interior Girder

9.7.17 Identify and Designate Steel Bridge Members and Components

It is the bridge designer's responsibility to identify "Fracture Critical Members (FCMs)", "Main Members", "Secondary Members" and "Primary Components of Main Members" in designing a new steel bridge and to designate or tabulate them explicitly on the contract documents (plans and/or special provisions). MTD 12-2 (Caltrans 2012) provides guidelines for identification of steel members for steel bridges. Figure 9.7-25 shows the member designations of steel girders for this bridge.



Notes:

T – Denotes Main Tension Member (Non-Fracture Critical Member)

C – Denotes Main Compression Member

Primary Components of Main Members – flanges, webs, splice plates and cover plates, longitudinal stiffeners, bearing stiffeners and connection stiffeners

Secondary Members – All members not designated as *T*, or *C*

Figure 9.7-25 Member Designations

NOTATION

A	=	fatigue detail category constant
$ADTT$	=	average daily truck traffic in one direction over the design life
$ADTT_{SL}$	=	single lane ADTT life
A_e	=	effective area (in. ²)
A_g	=	gross cross section area (in. ²)
A_n	=	net cross section area (in. ²)
A_{rb}	=	reinforcement area of bottom layer in concrete deck slab (in. ²)
A_{rt}	=	reinforcement area of top layer in concrete deck slab (in. ²)
A_{tg}	=	gross area along the cut carrying tension stress in block shear (in. ²)
A_{tn}	=	net area along the cut carrying tension stress in block shear (in. ²)
A_{vg}	=	gross area along the cut carrying shear stress in block shear (in. ²)
A_{vn}	=	net area along the cut carrying shear stress in block shear (in. ²)
b_c	=	width of compression steel flange (in.)
b_f	=	full width of the flange (in.)
b_{fc}	=	full width of a compression flange (in.)
b_{ft}	=	full width of a tension flange (in.)
b_s	=	width of concrete deck slab (in.)
b_t	=	width of tension steel flange (in.)
C	=	ratio of the shear-buckling resistance to the shear yield strength;
C_b	=	moment gradient modifier
D	=	web depth (in.)
D_{cp}	=	web depth in compression at the plastic moment (in.)
D_p	=	distance from the top of the concrete deck to the neutral axis of the composite sections at the plastic moment (in.)
D_t	=	total depth of the composite section (in.)
d	=	total depth of the steel section (in.)
d_o	=	transverse stiffener spacing (in.)
DC	=	dead load of structural components and nonstructural attachments
$DC1$	=	structural dead load, acting on the non-composite section
$DC2$	=	nonstructural dead load, acting on the long-term composite section

DF_m	=	live load distribution factor for moments
DF_v	=	live load distribution factor for shears
DW	=	dead load of wearing surface
E	=	modulus of elasticity of steel (ksi)
E_c	=	modulus of elasticity of concrete (ksi)
F_{crw}	=	nominal bend-buckling resistance of webs (ksi)
F_{exx}	=	classification strength specified of the weld metal
F_{nc}	=	nominal flexural resistance of the compression flange (ksi)
F_{nt}	=	nominal flexural resistance of the tension flange (ksi)
F_{yc}	=	specified minimum yield strength of a compression flange (ksi)
F_{yf}	=	specified minimum yield strength of a flange (ksi)
F_{yr}	=	compression-flange stress at the onset of nominal yielding including residual stress effects, taken as the smaller of $0.7F_{yc}$ and F_{yw} but not less than $0.5F_{yc}$ (ksi)
F_{yrb}	=	specified minimum yield strength of reinforcement of bottom layers (ksi)
F_{yrt}	=	specified minimum yield strength of reinforcement of top layers (ksi)
F_{ys}	=	specified minimum yield strength of a stiffener (ksi)
F_{yt}	=	specified minimum yield strength of a tension flange (ksi)
F_{yw}	=	specified minimum yield strength of a web (ksi)
f'_c	=	specified minimum concrete strength (ksi)
f_{bu}	=	flange stress calculated without consideration of the flange lateral bending (ksi)
f_{os}	=	flexural stress due to Service II at the extreme fiber of the other flange concurrent with f_s (ksi)
f_l	=	flange lateral bending stress (ksi)
f_c	=	longitudinal compressive stress in concrete deck without considering flange lateral bending (ksi)
f_s	=	maximum flexural stress due to Service II at the extreme fiber of the flange (ksi)
f_{sr}	=	fatigue stress range (ksi)
I	=	moment of inertia of a cross section (in. ⁴)
I_{ST}	=	moment of inertia of the transformed short-term composite section (in. ⁴)
I_t	=	moment of inertia for the transverse stiffener taken about the edge in contact with the web for single stiffeners and about the mid-thickness of the web for stiffener pairs (in. ⁴)

- I_{yc} = moment of inertia of the compression flange about the vertical axis in the plane of web (in.⁴)
- I_{yt} = moment of inertia of the tension flange about the vertical axis in the plane of web (in.⁴)
- K = effective length factor of a compression member
- K_a = surface condition factor
- K_g = longitudinal stiffness parameter
- K_h = hole size factor
- L = span length (ft)
- L_b = unbraced length of compression flange (in.)
- L_p = limiting unbraced length to achieve $R_b R_h F_{yc}$ (in.)
- L_r = limiting unbraced length to onset of nominal yielding (in.)
- M_{AD} = additional live load moment to cause yielding in either steel flange applied to the short-term composite section (kip-in.)
- M_{D1} = moment due to factored permanent loads applied to the steel section alone (kip-in.)
- M_{D2} = moment due to factored permanent loads such as wearing surface and barriers applied to the long-term composite section (kip-in.)
- M_n = nominal flexural resistance of the section (kip-in.)
- M_p = plastic moment (kip-in.)
- M_u = bending moment about the major axis of the cross section (kip-in.)
- M_y = yield moment (kip-in.)
- N = number of cycles of stress ranges; number of bolts
- N_b = number of girders
- N_{TH} = minimum number of stress cycles corresponding to constant-amplitude fatigue threshold, $(\Delta F)_{TH}$
- n = number of stress-range cycles per truck passage
- p = fraction of truck traffic in a single lane
- Q = first moment of transformed short-term area of the concrete deck about the neutral axis of the short-term composite section (in.³)
- Q_i = force effect
- R_h = hybrid factor
- R_b = web load-shedding factor
- R_n = nominal resistance

- R_p = reduction factor for hole
 S = girder spacing (in.); elastic section modulus (in.³)
 S_{LT} = elastic section modulus for long-term composite sections, respectively (in.³)
 S_{NC} = elastic section modulus for steel section alone (in.³)
 S_{ST} = elastic section modulus for short-term composite section (in.³)
 S_{xt} = elastic section modulus about the major axis of the section to the tension flange taken as M_{yt}/F_{yt} (in.³)
 t_c = thickness of compression steel flange (in.)
 t_f = thickness of the flange (in.)
 t_{fc} = thickness of a compression flange (in.)
 t_{ft} = thickness of a tension flange (in.)
 t_t = thickness of tension steel flange (in.)
 t_w = thickness of web (in.)
 t_s = thickness of concrete deck slab (in.)
 U_{bs} = reduction factor for block shear rupture
 U = reduction factor to account for shear lag
 V_{cr} = shear-buckling resistance (kip)
 V_n = nominal shear resistance (kip)
 V_p = plastic shear force (kip)
 λ_f = slenderness ratio for compression flange = $b_{fc}/2t_{fc}$
 λ_{pf} = limiting slenderness ratio for a compact flange
 λ_{nf} = limiting slenderness ratio for a noncompact flange
 γ_i = load factor
 η_D = ductility factor
 η_R = redundancy factor
 η_I = operational factor
 $(\Delta F)_{TH}$ = constant-amplitude fatigue threshold (ksi)
 $(\Delta F)_n$ = fatigue resistance (ksi)
 ϕ_f = resistance factor for flexure
 ϕ_v = resistance factor for shear
 ϕ_c = resistance factor for axial compression
 ϕ_u = resistance factor for tension, fracture in net section

ϕ_y	=	resistance factor for tension, yielding in gross section
ϕ_b	=	resistance factor for bearing on milled surfaces
ϕ_{bb}	=	resistance factor for bolt bearing on material
ϕ_{sc}	=	resistance factor for shear connector
ϕ_{bs}	=	resistance factor for block shear rupture
ϕ_s	=	resistance factor for bolts in shear
ϕ_{e2}	=	resistance factor for shear in throat of weld metal in fillet weld

REFERENCES

1. AASHTO, (2012). *AASHTO LRFD Bridge Design Specifications*, Customary US Units, (6th Edition), American Association of State Highway and Transportation Officials, Washington, DC.
2. AASHTO, (2002). *Standard Specifications for Highway Bridges*, 17th Edition, American Association of State Highway and Transportation Officials, Washington, DC.
3. Azizinamini, A., (2007). *Development of a Steel Bridge System Simple for Dead Load and Continuous for Live Load, Volume 1: Analysis and Recommendations*, National Bridge Research Organization, Lincoln, NE.
4. Barker, R. M. and Puckett, J. A., (2013). *Design of Highway Bridges - Based on AASHTO LRFD Bridge Design Specification*, 2nd Edition, John Wiley & Sons, Inc., New York, NY.
5. Caltrans, (2014). *California Amendments to AASHTO LRFD Bridge Design Specifications – Sixth Edition*, California Department of Transportation, Sacramento, CA.
6. Caltrans, (2012). *Bridge Memo to Designers 12-2: Guidelines for Identification of Steel Bridge Members*, California Department of Transportation, Sacramento, CA.
7. Caltrans, (2008). *Bridge Memo to Designers 10-20: Deck and Soffit Slab*, California Department of Transportation, Sacramento, CA.
8. Caltrans, (2004a). *Bridge Memo to Designers 12-4: Criteria for Control Dimension “Y” on Steel Girders*, California Department of Transportation, Sacramento, CA.
9. Caltrans, (2004b). *Bridge Memo to Designers 12-3: Camber of Steel-Concrete Composite Girders*, California Department of Transportation, Sacramento, CA.



10. Caltrans, (2000). *Bridge Design Specifications*, LFD Version, April 2000, California Department of Transportation, Sacramento, CA.
11. Caltrans, (2015). *Bridge Memo to Designers 8-7: Stay-in-Place Metal Forms for Cast-in-Place Concrete Decks in Precast Concrete and Steel Superstructures*, California Department of Transportation, Sacramento, CA.
12. Caltrans, (1988). *Bridge Memo to Designers 15-17: Future Wearing Surface*, California Department of Transportation, Sacramento, CA.
13. Chen, W.F., and Duan, L., (2014). *Bridge Engineering Handbook, 2nd Edition: Superstructure Design*, CRC Press, Boca Raton, FL.
14. FHWA, (2012). *Steel Bridge Design Handbook*, FHWA NHI-12-052, Federal Highway Administration, Washington, DC. <http://www.fhwa.dot.gov/bridge/steel/pubs/if12052/>
15. Taly, N., (2014). *Highway Bridge Superstructure Engineering: LRFD Approaches to Design and Analysis*, CRC Press, Boca Raton, FL.